

# SRF Project Plan

**Tawas Utilities Authority  
June 1, 2021 – Adopted Plan  
SRF Project Number 5721-01**



123 W. Main St. Suite 200  
Gaylord, MI 49735

**TABLE OF CONTENTS**

**Chapter 1 – Project Plan Contents**.....1

1.1 Environmental Setting.....4

1.2 Population Data.....11

1.3 Economic Characteristics.....11

1.4 Existing Facilities.....12

1.5 Fiscal Sustainability Plan.....13

1.6 Need for the Project.....15

**Chapter 2 – Analysis of Alternatives**.....16

2.1 Identification of Potential Alternatives.....16

2.2 Analysis of Principal Alternatives.....18

**Chapter 3 – Selected Alternatives**.....34

3.1 Authority to Implement the Selected Alternative.....39

3.2 User Costs.....39

3.3 Disadvantaged Community.....40

3.4 Useful Life.....40

**Chapter 4 – Evaluation of Environmental Impacts**.....40

4.1 Analysis of the Impacts.....41

**Chapter 5 – Mitigation**.....41

5.1 Short-Term Construction Related Mitigation.....41

5.2 Mitigation of Long-Term Impacts.....42

5.3 Mitigation of Indirect Impacts.....42

**Chapter 6 – Public Participation**.....43

6.1 Public Meetings on Project Alternatives.....43

6.2 The Formal Public Hearing.....44

6.3 Comments Received and Answered.....44

6.4 Adoption of the Project Plan.....44

**LIST OF FIGURES**

Figure 1. Project Location Map.....3

Figure 2. Sewer Service Area.....3

Figure 3. Baldwin Sewer Service Area Map.....4

Figure 4. Wetlands Map.....5

Figure 5. Coastal Zones Map.....5

Figure 6. Flood Plains Map (Source: FEMA).....6

Figure 7. East Tawas Existing Land Use.....7

Figure 8. Tawas City Existing Land Use.....8

Figure 9. Topographic Map (Source: USGS).....9

Figure 10 . Project Area Soils Map.....10

**LIST OF TABLES**

Table 1. Rare Species Review.....11

Table 2. Tawas Utility Authority Study/Service Area Population/Projections.....11

Table 3. Employment Industry.....12

Table 4. Cost Effective Analysis for Alternatives.....27

Table 5. Environmental Evaluation.....29

Table 6. Alternative Advantages and Disadvantages.....32

Table 7. Alternative Ranking.....33

Table 8. Schedule.....37

Table 9. Project Costs and Priority.....38

**LIST OF PICTURES**

Picture 1. Secondary Clarifier.....14

Picture 2. Secondary Clarifier Structural Damage.....14

## **APPENDICES**

Appendix A	Previous Reports
Appendix B	NPDES Permit and Compliance Notices
Appendix C	Environmental Information
Appendix D	Cost Basis
Appendix E	Public Participation
Appendix F	Process Flow Diagrams
Appendix G	Design Data and Process Modeling
Appendix H	Disadvantaged Community Status
Appendix I	Green Project Reserve Information

**End of Table of Contents**

## CHAPTER 1 – PROJECT PLAN CONTENTS

The Tawas Utilities Authority (TUA) Wastewater Treatment Plant (WWTP) was originally constructed in 1966 and is located adjacent to the Tawas River in the City of East Tawas. The plant currently sees flows that average 1 Million Gallons per Day and services the City of East Tawas, the City of Tawas City and a portion of Baldwin Township. The Authority was established by the Cities of East Tawas and Tawas City to provide regional sewage treatment. Each entity has ownership of 50% of the WWTP and pays 50% of the expenses (less income). Baldwin Township is a customer and billed by the TUA on an established usage rate, and in 2019, the Baldwin Township revenues covered approximately 8% of the TUA expenses. The Authority was established under Act 233, and the TUA has the authority to implement and bond for any improvement projects.

The TUA only has ownership and operational responsibilities for the WWTP. Each municipality owns and operates their individual sanitary sewer collection systems. Each municipality establishes their own individual sewer rates and charges, which generate revenues to operate their own sewer collection systems and to pay their share of the TUA expense. Baldwin Township also owns and operates their sewer collection system, which discharges to the City of East Tawas sewer system. Therefore, Baldwin Township user rates collect revenues to cover expenses for operational expenses for their own sewer collection system, charges from the City of East Tawas for usage of a portion of their system, and usage charges from the TUA.

This SRF Project Plan is for the Tawas Utilities Authority WWTP only, and does not include any review or improvements to the individual municipality's sanitary sewer collection systems.

Originally, the plant process utilized Primary Clarifiers, a Single Digester and Sludge Drying Beds for treatment. The plant has since been expanded upon and many components have been replaced. In 1989, a major expansion project was completed, and the following items were added to the treatment process: an inline grinder for pretreatment, grit removal system, primary clarifier volume upgrade, secondary biological treatment, chemical feed system, additional digester and sludge storage tank, chlorine disinfection, polymer feed, decant tanks, sludge thickener and filter press and a chlorinated effluent system. This project was completed to accommodate increasing flows. In 1999 an Odor Control System was added and in 2010 and 2015 the influent pumps and grit removal system were replaced, respectively. Most assets in operation are well beyond their manufactured life cycle, but effective operation and maintenance has pushed the aged equipment past this limit. As such, the equipment conditions range from good to poor.

The East Tawas raw sewage flows from a 21" gravity sewer to the existing 2" bar screens that must be manually cleaned. At a specific elevation in the wet well, 3 pumps pump flow toward the existing grit chamber. It is at this point where flows from Tawas City are included. From the grit chamber the flow enters a down-opening weir where either the flow goes through a 24" primary bypass or to the primary clarifier via a 24" pipe. Flows from the primary clarifier and bypass meet and can either go toward the return sludge blending chamber or through a 24" secondary bypass going directly to the chlorine contact chamber. After the blending chamber, the flow is directed to two (2) oxidation ditches (inner and outer) and then the secondary clarifier. Finally, flow from the secondary clarifier goes to the chlorine contact chamber and exiting the WWTP through the discharge wet well and enters the Tawas River. Process flow diagrams for the existing facility process and solids flows are included in Appendix F.

This plant serves three (3) communities: The City of Tawas City, the City of East Tawas, and a portion of Baldwin Township. The aging infrastructure must be replaced in order to ensure that the facility can remain operational.

#### Geographic Area:

The study/service area includes the Tawas Utilities Authority Wastewater Treatment Plant (WWTP) property and service area. The treatment plant is located in the City of East Tawas. The WWTP property is bordered W. Franklin Street to the south, the Tawas River to the west, their property line to the north and Dewey Durant Park to the east. The location of the WWTP relative to the City of East Tawas can be seen in Figure 1.

The TUA provides wastewater treatment service to the majority of the areas lying within the Cities of Tawas City and East Tawas, and a portion of Baldwin Township. Maps depicting the sewer service areas are included as Figures 2 and 3.

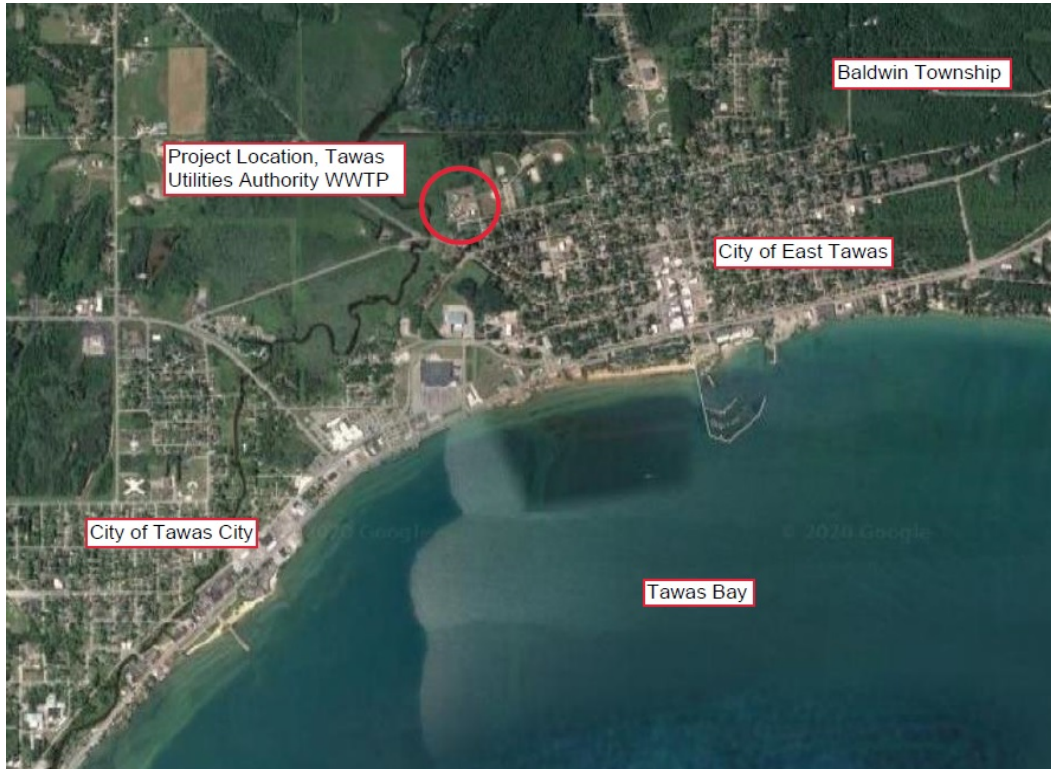

**Figure 1: Project Location Map**



**Figure 2: Tawas City/East Tawas Sewer Service Area**

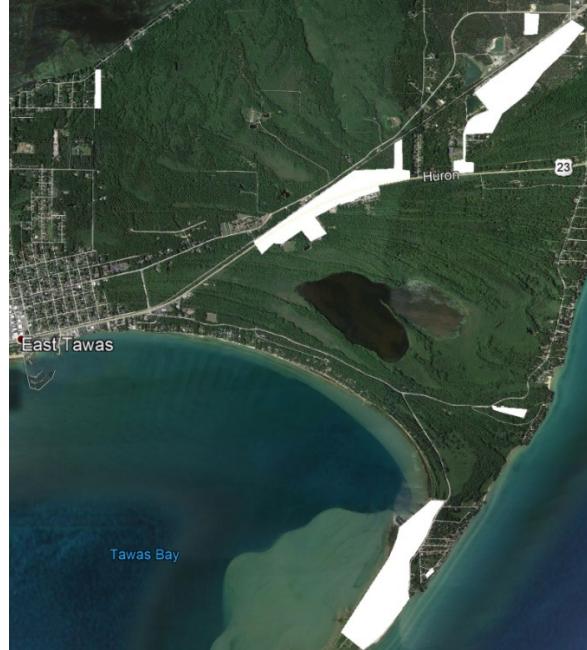

**Figure 3: Baldwin Sewer Service Area**

### 1.1 Environmental Setting

#### Cultural Resources:

A THPO application was sent to the Tribal Historic Preservation Office (THPO). Based upon the review by the Saginaw Chippewa Indian Tribe of Michigan's Tribal Historic Preservation Office (SCIT THPO) there are no recorded resources within the area of potential effect and the project will have no effect on cultural resources.

#### The Natural Environment:

- Air Quality:

The Local air quality is good to excellent and should not be impacted by the project.

- Wetlands:

The National Wetlands Inventory Map for the area around the Cities of East Tawas and Tawas City (Figure 4) illustrates the wetlands that are located within/adjacent to the study area. However, based upon a field review of the WWTP areas, all proposed work will be outside of any wetland areas, and therefore the proposed project will not adversely impact existing wetlands.



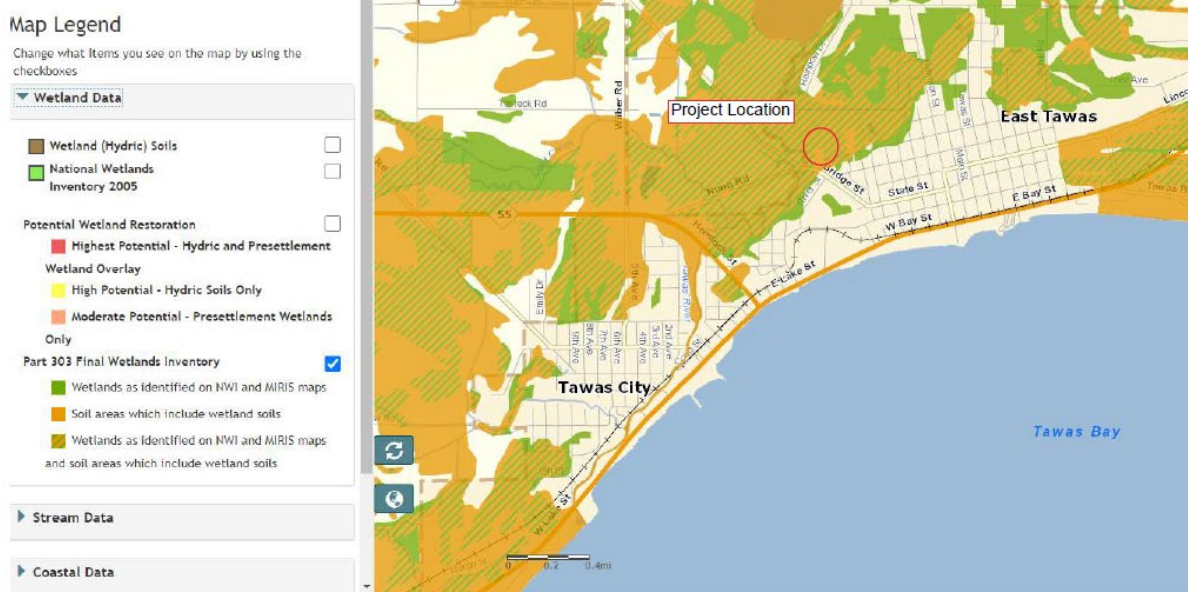

**Figure 4: Wetlands Map**

- Coastal Zones:  
Both Tawas City and East Tawas have coastal land on Tawas Bay, which is directly connected to Lake Huron (Figure 5 below).

**Iosco County**  
**Baldwin Township, T22N R9E and T22N R8E**  
**East Tawas, T22N R8E**  
**Tawas Township, T22N R8E and T22N R7E**  
**Tawas City, T22N R8E and T22N R7E**  
**Alabaster Township, T21N R7E**

The heavy red line is the **Coastal Zone Management Boundary**  
 The red hatched area is the **Coastal Zone Management Area**



**Figure 5: Coastal Zones Map**

- Floodplains:

The floodplain area within the Tawas study/service area generally follows the Tawas River and Tawas Bay coastline. As seen in Figure 6, the river is located between Tawas City and the City of East Tawas and then flows towards Tawas Bay. The proposed improvements will be constructed throughout the property and just inside of the flood zone. The actual WWTP area is located within Zone AE, which indicates a flood risk of once per hundred years. Modifications to the WWTP will occur within this same flood risk Zone AE, so no changes or impacts to the current flood risk will be created by this project.

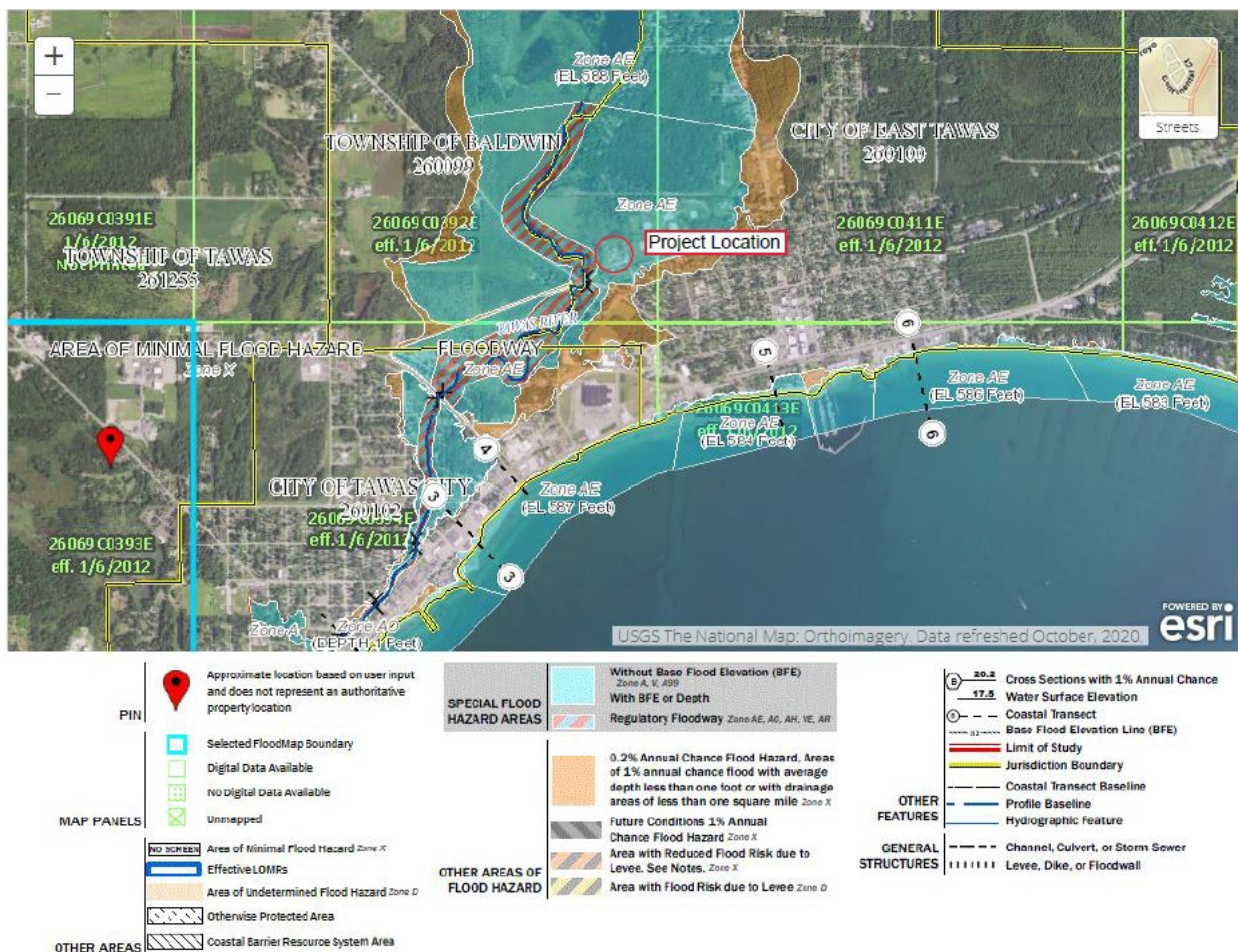
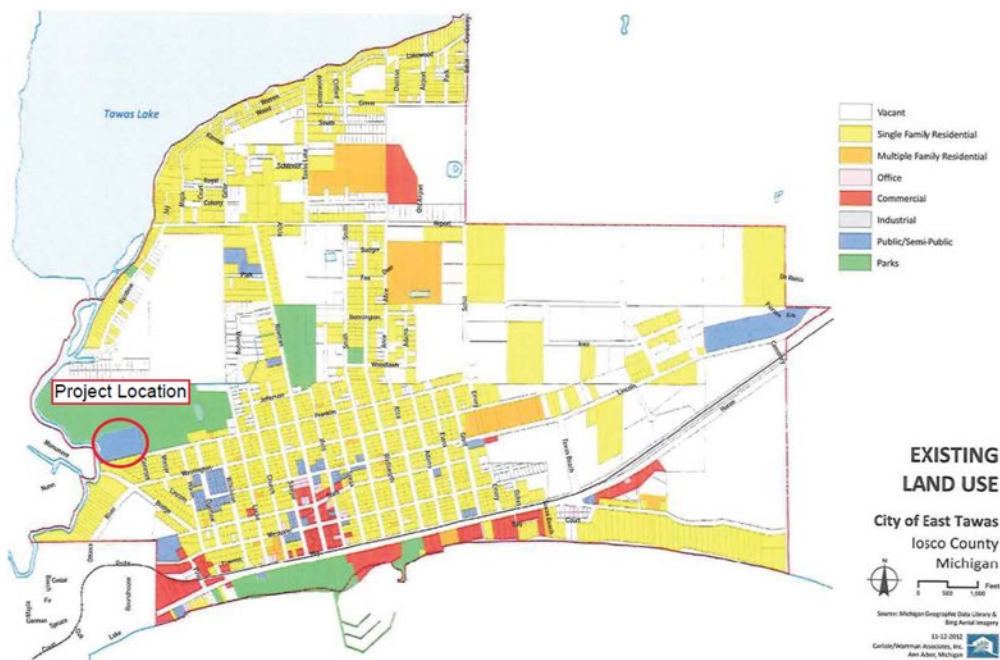

Figure 6: Floodplains Map (Source: FEMA)

- Natural or Wild and Scenic Rivers:

There are no federally designated Wild and Scenic Rivers or state designated Natural Rivers in the City of East Tawas and in the study area.

- Major Surface Waters:  
The Tawas River and Tawas Bay are the major surface water bodies in the study area.
- Recreational Facilities:  
The City of Tawas City and the City of East Tawas are home to many parks and other recreational facilities, including Tawas Point State Park. The closest recreational facility to the site is Dewey Durant Park which shares a property line to the east of the TUA WWTP site as seen in Figures 7 & 8.



**Figure 7: East Tawas Existing Land Use**



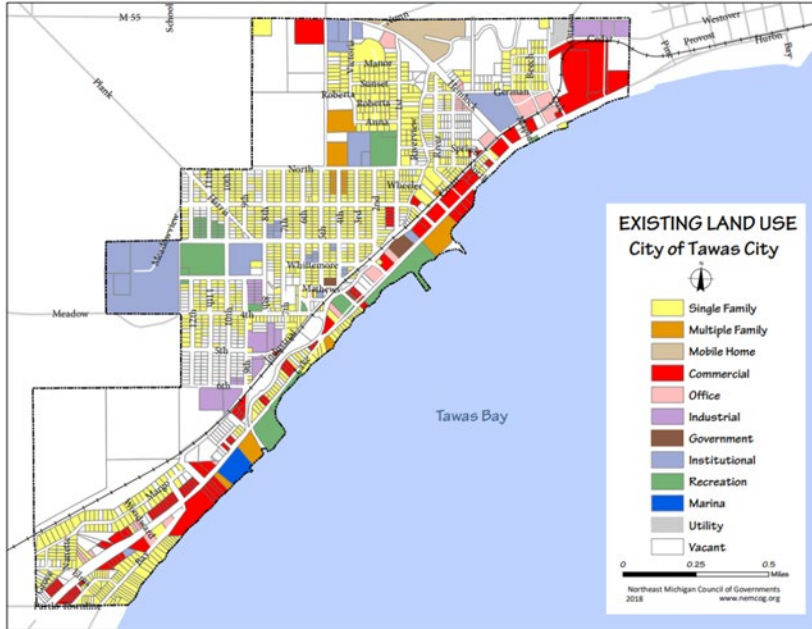

**Figure 8: Tawas City Existing Land Use**

- **Topography:**  
The project service area generally slopes from the northwest to the southeast with an elevation change (from northwest to southeast) of approximately 860 feet to 588 feet, respectively. See Figure 9 below.



**Figure 9: Topographic Map (Source: USGS)**

- **Geology:**  
The proposed project will not be affected by the geological structures/formations in/around the Tawas area. Outside of the Tawas River, which runs through the middle of the city, the area is geologically homogeneous.

- Soils:

No adverse soil condition exists that would impact the project and its construction. The soils within the project area consist primarily of Deford Muck (369), and Wurtsmith-Meehan; refer to Figure 10, Tawas WWTP Project Area Soils Map, which was excerpted from the USDA Natural Resources Conservation Service.



**Figure 10: Project Area Soils Map**

- Agricultural Resources:

There are no prime or unique farmlands within the project area.

- Fauna and Flora:

The proposed project was reviewed in accordance with the Endangered Species Act of 1973; it was concluded that there are no concerns as occurrences of these species are far removed from the proposed activity. Refer to Table 1 below.

**Table 1. Rare Species Review**

Type	Scientific Name	Common Name
Fauna	Percina copelandi	Channel darter
Fauna	Ligumia nasuta	Eastern pondmussel
Fauna	Gavia immer	Common loon
Flora	Zizania aquatica	Wild rice

**Land Use in Study Area:**

The predominant land uses within the City of East Tawas are Single Family Residential, Commercial, and Institutional. See the preceding Figure 7. Existing land use within the City of East Tawas is shown in the preceding Figure 8. Similar to Tawas City, the majority of land use within East Tawas is predominately single family residential. East Tawas also has some multi-family and commercial uses. There is no significant industrial component. Being a tourist/recreational destination, the City does have a good percentage of park area.

**1.2 Population**

Population/projections for the City of Tawas City and the City of East Tawas come from the 2016 City of Tawas City Master Plan and the 2013 City of East Tawas Master Plan population trends section. According to the Master Plans, the Tawas City population has increased by 1.4% and the East Tawas population is expected to decline by 0.38%. These rates were used for the five-year, ten-year and twenty year projections.

**Table 2. Tawas Utility Authority Study/Service Area Population/Projections**

Year	City of East Tawas	City of Tawas City
2016	2750	1852
2021	2698	1985
2026	2647	2128
2036	2550	2445
<b>Source: Tawas City and East Tawas Master Plans</b>		

**1.3 Economic Characteristics**

The three major industries in Tawas City include Educational Services & Healthcare, Manufacturing, and Retail Trade. As seen in Table 3 and according to the Tawas City Master Plan, the three industries account for over 50% of the industry in the City. Similar data for East Tawas was not provided within their master plan, however similar characteristics would be expected.

The median household income for the City of Tawas City is \$37,321 (US Census 2016) and is \$30,229 for the City of East Tawas (US Census 2010). The average income of each city is below that of Iosco County, the State of Michigan and the United States. Poverty rates for each city, 10.9% in Tawas City and 10.2% for East Tawas are also lower than Iosco County (11.7%) and the State of Michigan (11.5%) according to the US Census 2016.

**Table 3. Employment Industry**

Industry	Tawas City	
	Number of Jobs	Percent of Jobs
Educational, Health and Social Services	201	25.5
Manufacturing	132	16.8
Retail Trade	99	12.6
Arts, Entertainment, Recreation, Accommodation, Food Services	92	11.7
Professional, Scientific, Management, Admin., Waste Management	54	6.9
Finance, Insurance, Real Estate	51	6.5
Construction	40	5.1
Transportation & Warehousing	38	4.8
Other Services (Except Public Services)	32	4.1
Public Administration	21	2.7
Agriculture, Forestry, Fishing, Hunting, Mining	10	2.4
Information	10	1.3
Wholesale Trade	7	0.9
<b>Total</b>	<b>787</b>	<b>100</b>
<b>Source: 2016 Tawas City Master Plan</b>		

1.4 Existing Facilities

The WWTP is located in the City of East Tawas, adjacent to the Tawas River. The plant was originally constructed in 1966 and went through a major expansion in 1989. The WWTP consists of primary clarifiers, grit removal system, secondary clarifiers & oxidation ditches, chlorine disinfection, decant tanks and a sludge thickener & filter press, and an odor control system.



The East Tawas raw sewage flows from a 21" gravity sewer to the existing 2" bar screens that must be manually cleaned. At specific elevations in the wet well, 3 pumps pump flow toward the existing grit chamber. It is at this point where flows from Tawas City are included. From the grit chamber the flow enters a down-opening weir where either the flow goes through a 24" primary bypass or to the primary clarifier via a 24" pipe. Flows from the primary clarifier and bypass meet and can either go toward the return sludge blending chamber or through a 24" secondary bypass going directly to the chlorine contact chamber. After the blending chamber, the flow is directed to two (2) oxidation ditches (inner and outer) and then the secondary clarifier. Finally, flow from the secondary clarifier goes to the chlorine contact chamber and exiting the WWTP through the discharge wet well and enters the Tawas River.

### 1.5 Fiscal Sustainability Plan

All capital projects have an established priority and include estimated project costs. Project costs include Engineering, Legal, and Contingency costs associated with each project. Possible funding sources have also been identified which include, sale of bonds (either at the local level or through the State), and Federal assistance programs such as the MEDC CDBG Grant Program, and the State Revolving Funding (SRF) Program.

The critical asset evaluation and inventory is below:

- East Tawas Headworks and Pumping: Flow from East Tawas passes through a manually cleaned 2" bar screen at the head of the plant. Following the screen flow is pumped to the grit removal structure where it is combined with the flow from Tawas City. The existing raw sewage pumps were recently replaced and are in good condition.
- Grit Removal: An aerated grit removal system with a washer/classifier is used for grit removal. This unit was recently upgraded and is in good condition.
- Primary Clarifiers: Two rectangular primary clarifiers with chain and flight collectors provide primary clarification. The tanks are from the original plant construction in 1966. The scraper-skimmer mechanisms were replaced in 1989. There is significant concrete spalling on the tank.
- Secondary Clarifier and Oxidation Ditches: The existing secondary clarifiers and oxidation ditches were installed as a part of the major expansion project in 1989. Since then, the equipment has not been replaced or rehabilitated. As seen in Pictures 1 and 2 below, there is structural damage on the oxidation channel and walking platform.
- Waste and Return Sludge Pumping: Sludge is drawn off of the clarifiers into a well using telescopic valves. From the well, return sludge is pumped back to the ditch inlets, and waste sludge to a thickener. Metering is provided for RAS. The equipment is functional, but past the end of its useful life.

- Chlorination-De-Chlorination System: Gas chlorine is added through an eductor pump located the head of the contact chamber. Gas Sulphur dioxide is added at the end of contact chamber for de-chlorination. Gas for both system is stored in 150 lb cylinders, with vacuum feed systems. The system functions in normal flows, but does not have sufficient capacity for peak flows.



Picture 1. Secondary Clarifier



Picture 2. Secondary Clarifier Structural Damage

### 1.6 Need for the Project

The TUA WWTP has been in operation since the 1966 and has seen many improvements throughout it's time. The project plan is to upgrade the headworks screening, secondary clarifier mechanicals parts, grit system odor control and the disinfection system. The existing facilities are at or are beyond their useful life span and require significant maintenance to remain operable. Completion of this project will increase efficiency and longevity of the WWTP.

#### Compliance Status:

The WWTP generally meets the National Pollutant Discharge Elimination System permit limitations for Ammonia-Nitrogen and CBOD5 according to data we received from TUA.

On March 31, 2021, The EGLE Water Resources Division issued a violation notice, VN-011588, to the TUA WWTP. The Violation Notice identified various monitoring violations between September 2018 and October 2020, and required TUA to provide a schedule for completion and proposed funding to implement the capital improvements identified in the facilities' Asset Management Plan (AMP). This project plan is intended to correct the known deficiencies identified in the AMP and update the aging equipment and facilities to provide compliance with the permit limitations. A copy of the Violation Notice is included in Appendix B of the project Plan.

#### Consent Orders:

There are no consent orders associated with this project.

#### Water Quality Problems:

There are no water quality problems associated with this project. The proposed projects will replace equipment at the end of their useful life and improve water treatment. If these projects are not undertaken, the plant functionality will be diminished, potentially resulting in detrimental impacts to water quality.

#### Project Need for the Next 20 Years:

The equipment that is proposed to be improved will have reached the end of their life cycles in the next 20 years. This will cause harm to the service area as poorly or untreated water would be cycled throughout the distribution system if the WWTP were to be left as is. Over the next 20 years, project costs could increase as more parts of the facility deteriorate and reach the end of their respective life cycles. Completion of the proposed project will mitigate that issue and increase the longevity of the WWTP.

#### Future Environment without the Proposed Project:

The future environment without the proposed project will remain the same. However, the quality of the effluent water will decrease as the infrastructure ages. The WWTP is adjacent to the Tawas River, to which it discharges. The improperly or partially treated wastewater discharged to the river will have a significantly negative impact to the river. Since the infrastructure is already reaching its functional life limit, this would still be an unsafe situation for the remaining residents if nothing were to change. This project will increase the efficiency of WWTP and its ability to properly treat water to the service area.

## CHAPTER 2 – ANALYSIS OF ALTERNATIVES

### 2.1 Identification of Potential Alternative

The following several paragraphs describe and assess common alternatives which must be considered whenever large capital expenditures are planned. Following this, a section entitled Analysis of Principle Alternative provides a detailed option review of the options that are considered most feasible.

#### No Action:

The existing facility is between 57 and 36 years old and a significant portion of the physical components of the facility are well past the end of their useful life. In addition, the operations staff have identified operational issues that should be corrected to provide a reliable treatment system. As such, no-action on a plant wide basis was not considered feasible, as no-action would result in several continuing adverse impacts on the WWTP and its customers. Included among such impacts are:

- Degradation of facilities and reduction in value of past citizen investments
- Continued risk of process overflow under peak hydraulic conditions (this is being evaluated by the new operations management firm to determine if it is an operational or process issue).
- Increasing potential for NPDES permit violations
- Excess energy use (natural gas for digester heating, inefficient motors and lighting systems)
- Inefficient operations (including lack of operational control due to outdated control systems)

#### Optimum Performance of Existing Facilities:

Optimizing the existing facilities has the potential to improve plant performance in the short term. However, capital improvements are necessary to incorporate improved technologies, restore the service life to facilities and system, take advantage of improvements to reduce energy use and to improve the sustainability of the facility. The cost and scope of

the work required to ensure optimal plant performance over the next 20 years and longer cannot be achieved without capital funding financed over the life of the project.

#### Water and Energy Efficiency:

Selected equipment shall have greater energy efficiency versus original components. Equipment items are to be optimized and controlled via variable frequency drives (VFD) which will improve efficiency. Electric motors will be high efficiency types.

#### Regional Alternatives:

The TUA is a regional system serving two cities and a portion of an adjacent township. Future development in the region would likely look to the TUA facility as an expanded regional facility. At present there is currently minimal opportunity for expanding the Authorities service area. The existing facility has excess treatment capacity to provide treatment for expansion of sewer collection areas and growth well into the future.

#### Alternatives to be evaluated:

The existing Asset Management Plans (AMP), plant operations and other data available were reviewed along with an onsite evaluation of the facility, and discussions with the operations staff.

Based on this review a determination was made that the existing oxidation ditches and secondary clarifiers were generally in good physical condition, and with sufficient rehabilitation could easily continue in operation for the duration of the planning period. As such, the alternative analysis is premised on maintaining and upgrading the existing oxidation ditch and secondary clarifiers.

#### Two alternatives were evaluated:

- Primary Clarification and Anaerobic Digestion: Maintain the current process with primary clarification and anaerobic digestion
- Aerobic digestion without primary clarification: Eliminate primary clarifiers and replace anaerobic digester with aerobic digestion.

The evaluated alternatives contain multiple common elements. Options for each of these items will be identified and evaluated. The selected options will be included in the overall evaluation of the two options selected.

- Headworks improvements to incorporate automatic fine screening

- Upgrades for the Oxidation ditch aeration system.
- Rehabilitation of the secondary clarifier mechanisms
- Control measures for RAS and WAS sludge pumping.
- Upgrade the existing digital SCADA system
- Addition of tertiary filtration
- Conversion from gas to UV disinfection or sodium hypochlorite.
- Sludge mixing system improvements and additional sludge storage capacity

## 2.2 Analysis of Principal Alternatives

### Alternative 1 - Primary Clarification and Anaerobic Digestion:

The existing two rectangular primary clarifiers were constructed in 1966. The chain and flight mechanisms were replaced in 1989 and are in reasonable condition. The concrete structure is in fair condition, with significant spalling of the concrete on the sides of the structure and stairs.

Rehabilitation of the two clarifiers would consist of removing a unit from service, cleaning, repairing and coating the structure as needed. The existing chain and flight collectors would be reinstalled. New weirs, and scum trough would be provided.

Two anaerobic digesters, (east and west units) are operated in series as a primary and secondary digester to treat the primary sludge. The secondary digester (west) has a floating cover to provide pressurization of the biogas generated in the digesters. The older West digester was installed in 1967, the newer east digester was installed in 1986. Most of the process piping and the heat exchanger and boiler were installed in 1986.

At present, waste activated sludge (WAS) is not added to the digesters on a year round basis. In winter WAS is thickened and pumped to the storage tank. The operations staff has reported difficulty in mixing WAS with the anaerobic digester in the winter due to the low temperature of the sludge.

The two digesters are covered with spray foam insulation which is in poor condition. The existing system does not reliably produce biogas, and supplementary natural gas is needed in the winter to maintain proper operating temperatures. The limited gas production may be due to leakage from the floating cover on the west digester. The relatively low influent BOD may also hinder gas production due to a limited availability of biomass.

Digester rehabilitation would require isolating one unit at a time, stripping the foam and rehabilitation of the concrete tank. The floating cover on the west digester would need to be removed. Rehabilitation would also include replacement of the boiler and heat exchanger, and all of the exposed process piping and mixing and transfer pumps.

#### Alternative 2 - Aerobic digestion without Primary Clarification:

This alternative is dependent on the ability of the oxidation ditches to provide full treatment to the permit limits for BOD and ammonia without the removals in the primary clarifiers. To verify this, a computer model of the existing facility was developed and calibrated based on the past operations data. The model was then run using the design flow of 2.4 MGD and with influent BOD, suspended solids and ammonia levels representative of typical municipal sewage. The model indicated that the existing secondary systems are capable of meeting the effluent limits at full flow and a higher organic loading without primary clarification.

Abandoning Primary Clarifiers is very straightforward. Flow would be sent to the oxidation ditches from the grit structure. There are existing control gates at the grit unit and piping in the facility to send flow directly to the oxidation ditches from the grit chamber, by-passing the primary clarifiers.

Eliminating the primary clarifiers will also eliminate the primary biomass feed to the anaerobic digesters. As noted, the anaerobic digesters do not reliably produce gas at present, and without the organic loading from the primary clarifiers, the anaerobic digester will likely not have sufficient biomass to operate in the thermophilic range without using natural gas for supplemental heating.

Aerobic digestion is generally preferred for digestion of waste activated sludge. The anaerobic digester has sufficient volume to meet 10 states requirements if the sludge is thickened to approximately 2.6 percent solids. At present WAS is thickened to approximately 4%. The existing anaerobic digesters will be converted to aerobic operation. This will include removal of the existing insulation, the floating cover on the west digester, and removal of all mixing and gas capture and management equipment. The tanks will be rehabilitated as needed. The digesters will be set up so that either unit may be operated in parallel or series. A proprietary high rate thermophilic digestion will be used to improve solids destruction and minimize sludge production and volumes for land application. A separate odor control system will be installed at the digesters to minimize odors from the digestion process. The biofilter system as described below is preferred for this application for the low operational costs and ability to fit the space available.



#### Headworks Improvement – Screening:

Influent to the plant from East Tawas and Tawas City enter the facility in separate pipelines. East Tawas flow is conveyed into the plant by gravity, passing through a two-inch manually raked coarse screen located in a well outside of the main building and covered to minimize odors. This screen primarily serves to protect the influent pumps. Influent from Tawas City is pumped and enters through a force main at the grit removal facility. A sewage grinder at the pump station in Tawas City grinds sewage prior to pumping.

Options for screening improvement considered the current industry best practices for removal of trash in the raw sewage that flows from both communities. Screening improvements would be designed to remove solids larger than 4 to 6 mm (1/4 or 3/8-inch). Improved fine screening will extend the life of downstream equipment and reduce overall WWTP maintenance. These processes are standard on nearly all small, medium and large WWTPs today. However, the current screening system is functional, and does not appear to contribute to the cause of current violations.

The options evaluated for the East Tawas influent are:

1. Retain Existing: This is a no-action option for this component of the facility. As noted, the existing screen requires manual cleaning and entry by plant staff into a below grade well. The well is uncovered, and provides minimum protection for the weather. Screenings are removed using a hoist.
2. Addition of a mechanically cleaned screen: A mechanically cleaned “climber type” bar screen would be capable of removing and conveying solids. The grade would provide the desired trash removal capability. The screenings would be conveyed up and deposited in a trash container located adjacent to the well. Unfortunately, this location is in the front of the plant and directly across from several homes. The ability to control odors for the screenings would be difficult. And the system would be a somewhat unsightly addition to the facility. A manual screen would need to be provided as a back up to the mechanical screen.
3. Addition of an in-channel sewage grinder: Addition of a sewage grinder in the existing channel would provide proper protection for the existing pumps. Trash would have passed through the pumps. This option would allow the influent channel to be covered during normal operation and minimize odor generation. A manual bar screen would need to be provided as backup to the mechanical grinder.

Trash removal options for the full plant flow considered are:

1. No additional screening: This option would be feasible if a fine screen was added at the East Tawas inlet (Option 2 above). This would allow ground trash for the Tawas City station to enter the plant. The current lack of screening



has been noted as an area of concern by TUA and the plant operation staff. This also removes operational control of trash removal for the Plant facility.

2. Addition of a mechanically cleaned screen: A mechanically cleaned fine screen, would be installed in upstream of the grit removal unit in an addition to the existing grit removal structure. The screenings would be conveyed to a container located at the grit building up and deposited in a trash container located adjacent to or combined with grit disposal.
3. Additional Concerns: TUA requires that odors from the plant be minimized wherever possible. Screening and disposal of the raw sewage presents a significant source of odors. The Tawas City inlet and grit systems both have odor control systems. Any improvements to the screening must incorporate upgrades to odor control system.

The selected options for screening improvements is Option 3 for East Tawas and Option 2 for the whole plant. This will provide protection of the raw sewage lift pumps, fully screen incoming trash, and allow a single odor control system be used for screenings and grit removal. Various types of equipment are available to serve the fine screening function and can be considered for TUA:

1. Chain and sprocket driven inclined bar screens are heavy duty, minimize head loss, and require the least maintenance. These also require somewhat more headroom but are cost effective. Modern units can be obtained without submerged sprockets if desired.
2. Inclined perforated plate screens are more efficient at removing solids to very low levels, but create greater hydraulic loss and are somewhat costlier upfront. Headroom requirements are similar to mechanical bar screens.
3. Flow-through perforated plate screens are similar to inclined units but provide increased hydraulic capacity by allowing raw sewage to flow between the two sides, through the screens, and out each of the two sides. These are the costliest of the alternatives.

C2AE recommends a mechanical bar screen with accompanying washer/compactor to provide effective solids removal, with the lowest possible maintenance and minimum head loss. It will be necessary to verify the physical layout of the selected equipment in the existing available space. An addition to the existing grit building will be necessary to house the screen.

#### Odor Control:

The facility currently has an odor control system at the East Tawas influent channel, the grit removal unit and the primary clarifiers. Options will be evaluated to combining the odor control systems and evaluate the methods used.

The inlet channel has a carbon adsorption unit fed by a fan drawing air from the channel. The carbon is replaced annually. The grit removal unit has a separate carbon adsorption unit a fed by fans.

Combining the systems will simplify the operations of the odor control system. A new odor control system would be located immediately north of the Grit Building. Three methods for Odor control were evaluated:

- Carbon Adsorption: Simple system that adsorbs odors into activated carbon. Once the carbon is saturated, no additional odor removal is possible without replacement of the media.
- Activated Biofilter: Utilizes wood chips in a large flat bed. Biological growth on the wood chips consumes odors from the air flow. These system are simple, requiring only that the bed be kept moist. Every several years the bed will be cleaned and new wood chips placed. A concern with these system is function during extended cold weather, and the size required.
- Proprietary “scrubber” systems: Systems are available from multiple manufacturers for odor removal using ionized air, biological system, and chemicals. An ionized air scrubber system was evaluated as this technology does not require regular replacement of media, and would provide consistent odor removal.

The ionization system was selected based on the ability to consistently provide odor control with minimal ongoing maintenance and no additional chemical costs.

#### Secondary Biological Treatment:

As noted above, a computer model of the treatment system indicates that the existing oxidation ditches have sufficient capacity to treat the design flow at higher biomass loadings than are currently received at the facility. The concrete structure is in reasonably good condition, with areas where concrete has spalled that require repair. At present only ditch-clarifier combination is typically in use with the two process trains (east and west) rotated on occasion to equalize wear on the equipment. The practice of only operating one oxidation ditch at a time is being evaluated by the new operations management firm.

Due to the present condition of the oxidation ditches, and the ability to meet the current flows with significant reserve capacity, replacing the oxidation ditches was not considered as an alternative.

#### Aeration Rotors:

The oxidation ditches each have two brush type surface aerators. The aerators are on common shafts with a single motor driving a pair of rotators, one in each ring of the unit. The aeration rotors located in the oxidation ditches are one of the most critical treatment process components in the plant. The microorganisms that perform the pollutant removal tasks in the secondary process rely upon adequate dissolved oxygen (DO) to perform their work and reproduce. The rotors also supply the mixing energy necessary to maintain the solids in the mixed liquor in suspension.

The existing surface aerators are 35 years old. Although they continue to provide adequate service, after this much time in service, these units should be thoroughly inspected and refurbished, if necessary, if they are to continue being mechanically reliable and operate at their optimum efficiency. The Authority has recently replaced the motors on two units and is considering replacement of the motors on the remaining units.

C2AE evaluated replacement of the aeration rotors. Newer units are available that will allow an increase in aeration efficiency, and are included in the proposed improvements.

#### Final Clarification:

The existing final settling tanks are circular structures located at the center of each oxidation ditch with a common wall with the ditch. The clarifiers utilize a circular collector mechanism. Replacement of the collector mechanisms, weirs, and baffles are included in the project.

#### WAS and RAS Draw off and Pumping:

Sludge is removed from the secondary clarifiers through a telescoping valve in a pair of interconnected wells. A single RAS pump draws sludge for each of the sludge wells for return to the clarifier. This line is metered to each process train. Waste sludge is discharged off the WAS piping through an automatic valve, metered and sent to the thickener.

The Plant operators have reported that the telescoping valves do not allow the desired level of control over sludge blanket levels and RAS volumes. This complicates the operational control, and ability to maintain optimal mixed liquor concentrations in the oxidation ditches.

The two RAS pumps have a capacity of 900 GPM each. This allow RAS flow at up to 108% of the influent flow, which is adequate. At the design flow with both ditches in operation, there is no redundancy in the pumping capacity, so the addition of a third pump is necessary.

The intent of the project will be to modify the secondary sludge draw off piping, and pumping configuration to include elimination of the telescopic valves, and add a third RAS pump.

#### Effluent Tertiary Treatment:

The TUA has infrequent violations of the effluent limits for suspended solids. Further NPDES permits may impose more rigid phosphorus or nitrogen limits. Granular media filters may be used as a supplemental, tertiary treatment unit process to aid in the removal of residual solids and nutrients from secondary treatment effluent. As discussed below, UV disinfection was evaluated for the project. Filtration upstream of the UV system would reduce the suspended solids loading, which increases disinfection efficiency, and minimizes cleaning. The available head between the secondary clarifiers and the outfall pipe is limited, and any filtration system would need to have minimal head loss to fit within the existing hydraulic grade line without requiring additional pumping. A traditional continuously backwashed filter is preferred for this application. Backwashing of a traditional sand filter would create a surge at the head of the plant, and also require storage of treated effluent. Based on these limitations, a cloth disk filter is recommended. The filters will need to be enclosed in a structure to prevent freezing in cold weather.

#### Disinfection Improvements:

The disinfection process at TUA utilizes chlorine gas. The gas is added into the chlorine contact chamber using an induced draft mixer. The chlorine contact tank is partially located under the Disinfection Building and cannot be readily drained for cleaning. The contact tank has a water depth of 13.5-feet with a volume of 113,500 gallons. The contact time is 63 minutes at the design flow. The contact tank is believed to be in good condition. De-chlorination is by sulfur Dioxide gas (SO<sub>2</sub>). The gas is stored in 150-lb cylinders.

The available disinfection contact times in TUA are well above recommended minimum values of 15 minutes listed in Ten State Standards. Although only one contact tank exists, the time in the long outfall is more than adequate to meet disinfection time requirements with the contact tank out of service.

#### Chlorine Feed System:

Chlorine gas is stored in 150-lb cylinders and is fed to solution with vacuum regulators. The feed capacity of the system is reported to be approximately 7 pounds per day (ppd) of chlorine. During high flow events, the facility is unable to draw sufficient gas from the cylinders to maintain the desired chlorine concentration in the contact tank.

The gas system was originally designed to use one-ton cylinders, which are no longer available due to lack of demand and community safety. The facility is located adjacent to a residential area and a City park. As such elimination of chlorine gas is desired to eliminate the potential hazards from gas storage.

Commonly two alternative disinfection processes have been used. These include feeding liquid Sodium Hypochlorite as an alternate source of chlorine, or converting to Ultraviolet Light Disinfection. Liquid Hypochlorite can be purchased in bulk or generated on site. Use of Sodium Hypochlorite for disinfection will require de-chlorination following the chlorine contact chamber. De-chlorination is typically achieved with liquid Sodium Bisulfite when Hypochlorite is used for disinfection.

TUA staff is trained, prepared, and comfortable feeding chlorine gas for disinfection. Chlorine has performed well, operators are trained to handle it in a safe manner and it is easily the most cost effective option available.

#### Instrumentation Improvements:

The existing control and monitoring system for the WWTP is digital based and has been upgraded regularly since 1993. A SCADA upgrade is recommended under this report. Other miscellaneous control modifications may be made so that equipment may restart automatically during a power outage event.

#### Design:

Miscellaneous items may include, but are not limited to, additional piping, building modifications (doorways/corridors), site improvements (access drives/drainage) etc.

#### Sludge Storage:

At present, digested sludge is disposed of by land application on farm land in the general vicinity of the facility. Hauling and disposal is contracted to a specialty firm engaged in biosolids management. The biosolids are typically applied in the spring before planting and in the fall after harvest. The existing sludge storage tank has sufficient volume for approximately 6-months of storage at the current flows. At the design flow, the storage capacity would be less than

three months. In the past two years the volume of sludge stored between the two seasonal application periods has been above 95% of the storage tank capacity. Based on current production projected to the design flow, additional storage capacity is required. The existing sludge storage tank is a glass lined, bolted steel tank with a dome roof. This type of tank is typically one of the lowest costs options for sludge storage. A second tank identical to the existing tank is proposed.

The existing tank can only be mixed by pumping sludge from the outlet to the inlet. This has limited ability to mix the contents. A better mixing system is desired to prevent the accumulation of solids on the bottom of the tank, and better mix the sludge for loading into tanker trucks for hauling to the disposal sites.

The mixing system should be able to use common pumps for the existing and proposed tanks, and also have the ability to act as a truck fill pump. Due to the limited access to the inside of the tanks and the need for a required permit for confined space entry procedures, a system with no moving components inside the tank is preferred. In addition, the mixing equipment cannot be readily mounted to the tank walls or dome cover. The selected system utilizes mixings nozzles mounted on the floor of the tanks, with piping and mixing pumps located outside of the tank.

#### General Concrete Repair:

In general, the WWTP is in good structural condition. In several locations within the existing facility, especially at locations subject to freezing in very moist environments, minor concrete deterioration and or spalling are visible. These areas should be repaired immediately to protect the remaining service life of existing concrete structures. Repairs normally include chipping away loose concrete and patching with latex modified, Portland cement based patching material. Deteriorated concrete exists at the following locations over the surface areas noted below. Inexpensive repair procedures should be successful in protecting the remaining concrete.

#### HVAC Upgrades:

The main building is currently heated using a hydronic system. The hot water is produced in the common boiler used for heating and anaerobic digesters. The preferred alternative includes removing the anaerobic digester and associated heat exchange equipment. As such, a new system will be needed. The proposed heating/cooling will be a geothermal type system utilizing the treated effluent as the heat source.

- The Monetary Evaluation:

A life cycle cost analysis of the two Alternatives is presented below in Table 4 in a standard SRF format.

**Table 4. Cost Effective Analysis for Alternatives**

Item	Description	Alternative 1	Alternative 2
1	Capital Costs	\$11,520,662	\$10,997,180
2	Annual Operation and Maintenance	\$30,119	\$25,527
3	Future Salvage Value	\$4,793,031	\$4,575,243
4	Present Worth of O&M	\$635,202	\$538,357
5	Present Worth of Salvage Value	\$5,298,448	\$5,193,853
6	Total Present Worth	\$17,454,312	\$16,593,230

Table Row Description:

1. Total capital costs from revised cost opinions in Appendix D, these are the most current form of proposed capital improvements. Appendix A and B developed the basis for 4 above.
2. Operation and maintenance costs represent the costs to for the alternatives components, only. Costs common to both alternatives are not included in these amounts.
3. Future salvage value based on structure life of 40 years, piping/valves 50 years, equipment 20 years.
4. Present Worth of O&M at 0.5% for 20 years.
5. Present value of future value at 0.5% for 20 years.
6. Total of lines 1, 4, and 5.

Capital Costs:

Capital costs for Alternative 1 are documented in Appendix A.

Present Worth:

The monetary evaluation is done in the form of Present Worth Evaluation. This is an established method of comparing options on a total life cycle basis including capital costs and operation and maintenance. The present worth evaluation for the TUA was conducted in an EGLE format using discount rates and time periods per 2019 requirements. Information regarding the period and specific rates is provided on the previous page in Table 4.

Salvage Value:

Salvage value refers to the value at the end of the 20-year evaluation period.

**Escalation:**

Escalation is the rate of inflation of construction dollars per year. For this report, an escalation of 3.0% per year was used. Improvement costs are escalated to 2019 dollars.

**Interest During Construction:**

Interest during construction was not applied in this present worth evaluation.

**Mitigation Costs:**

Mitigation costs are those needed to allow for correction or lessening the effects of environmental impacts. Mitigation costs also can include other cost impacts not directly included with construction activities. With project entirely within the existing WWTP site, no mitigating costs are included in this evaluation.

**User Costs:**

Potential impacts on user rates from the proposed project are presented later in this report. All of the proposed alternatives will impact user rates.

**Alternative Delivery Methods:**

It is proposed that improvements be implemented under the Design-Bid-Construct delivery method with a general contractor as opposed to construction manager. Alternative delivery methods such as Design Build and Multiple Prime Contractors will not be employed.

Based on the evaluation presented above, it is recommended that the Authority pursue upgrade of the existing WWTP.

**Staging Construction:**

Construction of improvements will be staged as needed to maintain the flow through the facility during construction of the proposed improvements.

- The Environmental Evaluation:

Correspondence related to environmental impact aspects of this project can be found in Appendix C.

Table 5 summarizes potential environmental and public health impacts of the evaluated alternatives with brief descriptions following.



**Table 5. Environmental Evaluation**

Category	No Action	Alternate #1	Alternate #2
Cultural Resources:			
- Historical/Archaeological	0	0	0
Natural Environmental:			
- Climate	0	0	0
- Air Quality	2	1	1
- Wetlands	0	0	0
- Coastal Zones	0	0	0
- Floodplains	0	0	0
- Natural Wild and Scenic Rivers	0	0	0
- Surface Waters	2	1	1
- Topography	0	0	1
- Geology	0	0	0
- Soils	0	1	1
- Agricultural Resources	0	0	0
- Sensitive Habitats	0	0	0
- Threatened or Endangered Species	0	0	0
- Unique Features	0	0	0
<b>Total (lower is less impact)</b>	<b>4</b>	<b>3</b>	<b>3</b>
(0 signifies no impact, 1 represents some impact, and 2 signifies the greatest impact)			

In general, the environmental impacts of the three alternatives are summarized as follows:

- No Action: This eliminates all short term impacts of construction, but does not provide the important long-term impacts of improved treatment performance, improved treatment reliability, enhanced biosolids treatment for reduced impact of land application, reduced energy use, and reduced potable water use.
- Alternative 1: All work will be on the existing developed site. No expansion of the site is needed. Work in undeveloped topography is not needed. Short term construction impacts of noise and dust are possible. Long term benefits of improved treatment performance, improved treatment reliability, enhanced biosolids treatment for reduced impact of land application, improved air quality, reduced energy use, and reduced potable water use are provided by Alternative 1.
- Alternative 2: Environmental impacts are similar to Alternative 1.

The following descriptions are related to evaluations in Table 5.

- Air Quality: Impacts are related to odors from aerobic treatment and release of digester gas to the environment. Alternative 1 provides a slightly lower potential for odors.
- Wetlands: Neither 1 nor 2 are expected to impact classified wetlands. Alternative 2 results in some construction in presently undeveloped area.
- Surface Waters: Alternatives 1 and 2 are equal in terms of positive environmental impacts offered as described above.
- Topography, Soils, and Geology: Alternative 2 has a slightly greater impact due to the larger area that will be on site that will be disturbed during construction.
- Implementation and Public Participation:

The TUA has completed construction projects over the past several decades. All are openly discussed at public Board meetings, including with user cost impacts. The Project Plan will be advertised and displayed for citizen review for one month prior to the Public Hearing. The TUA has contracted with an engineering design consultant for assistance in the planning process and with a bond counsel for assistance in arranging project funding.

- Technical and Other Considerations:

Infiltration and Inflow:

- General

Infiltration occurs when groundwater enters either mainline or service lateral sewers through cracked or broken pipes, footing drains, and defective pipe joints.

Inflow is surface runoff that enters the sanitary sewer system via loose/defective or vented manhole covers, broken pipes, and illegal storm drainage cross connections such as catch basin leads, yard drains, culverts, or roof drains.

- Overall System Flows Review

System-wide average base flow is estimated at 1.3 MGD, which is approximately 100 gpcd. The average annual billed potable water from the TUA's 2016 Water System Asset Management Plan is 1.1 MGD. The base sewer flow can be expected to be 10 to 20% higher than billed water to account for the smaller quantities of un-avoidable infiltration.

Biosolids and Residuals:

TUA treats biosolids from the primary tanks and final clarifiers with anaerobic digestion and relies upon land application on local farm fields.

#### Industrial Pretreatment:

TUA does receive non-domestic discharges but does not operate under a EGLE Industrial Pretreatment Program permit.

#### Growth Capacity:

The proposed 20-year future annual average flow rate is 2.4 MGD which is the 1986 design capacity of the WWTP.

Vessel and pipe sizing is adequate now and for the future. Improvements to maintenance and structural integrity are needed.

#### Areas Currently Without Sewers:

The majority of developed areas within the community service districts are all currently served. Since the plant is operating well below its rated capacity, there is opportunity to expand service districts and serve additional population without require plant capacity expansion.

#### Reliability:

One of the key reasons for this project is to protect facility integrity and enhance treatment reliability.

#### Alternative Sites and Routing:

All improvements under the alternatives evaluated are contained on the existing site. Considerations for alternate siting and routing are minimal.

#### Combined Sewer Overflows:

There are no combined sewer overflows associated with the TUA WWTP facility.

#### Project Site Contamination:

There are no known contamination sites at the area of the proposed project.

#### Green Project Reserve:

Some components of the project may qualify for the Green Project Reserve. EGLE is currently reviewing the Green Project Reserve requirements. The following items may qualify for Green Project Reserve:

- Geothermal (final effluent water) heating/cooling system
- \*Premium efficiency motors

- \*Energy efficient lighting upgrades
- \*SCADA systems
- \*Variable frequency drives

\*Indicates that a Business Case justification is required. Additional information is included in Appendix I.

Principal Alternatives Summary

The tables below (Table 6 and 7) summarize the advantages and disadvantages of each alternative and offer a ranking based on environmental, cost, technical and other issues.

**Table 6. Alternative Advantages and Disadvantages**

Alternate	Advantages	Disadvantages
<u>No Action</u>	<ul style="list-style-type: none"> <li>• Least initial capital cost</li> <li>• Less public disruption</li> </ul>	<ul style="list-style-type: none"> <li>• Potential treatment failure</li> <li>• Continued high O&amp;M costs</li> <li>• Lowest level of performance</li> <li>• Very rapid depreciation</li> </ul>
<u>Alternate #1</u> Maintain Primary Clarification Anaerobic Digestion.	<ul style="list-style-type: none"> <li>• Increase reliability</li> <li>• Improved sustainability</li> <li>• Improved performance</li> <li>• Investment is protected</li> <li>• Min. environmental impact</li> </ul>	<ul style="list-style-type: none"> <li>• Highest capital costs</li> <li>• Temporary construction environmental impacts</li> </ul>
<u>Alternate #2</u> Eliminate Primary Clarifiers, Convert to Aerobic Digestion	<ul style="list-style-type: none"> <li>• Increase reliability</li> <li>• Reduced O&amp;M costs</li> <li>• Improved sustainability</li> <li>• Improved performance</li> <li>• Investment is protected</li> </ul>	<ul style="list-style-type: none"> <li>• Significant capital costs</li> <li>• Temporary construction environmental impacts</li> </ul>

**Table 7. Alternative Ranking**

Item	Category	No Action	Alternate #1	Alternate #2
1.	Short Term Environmental Impacts	3	1	1
2.	Long Term Environmental Impacts	1	3	3
3.	Mitigation of Environmental Impacts	3	2	2
4.	Reliability	1	2	3
5.	Implementation	3	2	1
6.	Infrastructure Improvements	1	2	3
7.	Growth Capacity	1	3	3
8.	Annual Costs	3	1	2
9.	Operation & Maintenance	1	3	3
10.	Water Quality	1	3	3
11.	Emergency Redundancy	1	3	3
12.	Probability of Success	1	3	3
Totals (higher is better)		<b>20</b>	<b>28</b>	<b>30</b>

- Short-term Environmental Impacts: Principal short-term impacts are those resulting from construction such as removal of vegetation, soil erosion, sedimentation, noise, dust, and traffic disruption.
- Long-term Environmental Impacts: In evaluating long-term impacts, important considerations are the severity of permanent displacement of natural flora and fauna, quality of the effluent discharged to the receiving water, energy and resource costs and changes in land use and productivity caused by the project.
- Mitigation of Environmental Impacts: The mitigation category ranks alternatives on the basis of the difficulty and cost to provide environmental impact mitigation measures such as erosion control during construction.
- Reliability: Reliability is judged in terms of probability of malfunction, necessary maintenance and other associated problems.
- Implementation Capability: This evaluation category indicates the ability of State, regional and local units of government to reach agreement on a plan and to fund and carry through with the plan.
- Infrastructure Improvement: This category rates the alternatives in order of the amount of incidental beneficial infrastructure (utilities) improvement resulting from a project alternative.
- Growth Capacity: Growth capacity gauges incidental system capacity growth potential resulting from problem correction actions.
- Annual Costs: Ranking in this category is based on estimated annual costs to the typical user for each alternative.

9. Operation & Maintenance: This category is based on the estimated system operation and maintenance needs for each alternative.
10. Water Quality: Water quality is based on the ability of each alternative to protect existing ground and surface waters.
11. Emergency Redundancy: The ability of an alternative to provide treatment redundancy for emergencies.
12. Probability of Success: Probability that a given alternative would be followed through and solve system deficiencies.

### CHAPTER 3 – SELECTED ALTERNATIVES

#### Relevant Design Parameters:

The recommended alternative is a comprehensive capital improvement project to upgrade the existing facility and process, as described in the previous section. This alternative includes the following capital improvements to the TUA WWTP. More detail of the specific improvements recommended under each heading is provided in the following sections. Note that the recommended project is a comprehensive project that provides the most cost effective solution over the long term and should minimize the need for any major improvements over the next 20 years. However, if the overall project cost or user cost increases are excessive and deemed not acceptable, the minimum project should be implemented to address the on-going discharge violations in terms of suspended solids and fecal coliform. Items that appear necessary to specifically address the violations are noted with an asterisk (\*), in case the project needs to be constructed in phases. Those items identified with an asterisk would need to be constructed as a first phase.

1. Headworks improvements to incorporate automatic fine screening and improved odor control
2. Elimination of primary clarifiers
3. \*Rehabilitation of the existing oxidation ditches, secondary clarifiers
4. \*Modification to the return and waste sludge pumping equipment to improve process control
5. Incorporate tertiary treatment, in the form of cloth disk filtration unit process, to aid in suspended solids and nutrient removal
6. \*Improve disinfection system
7. Elimination of the anaerobic digesters
8. Addition of aerobic digestion
9. \*Additional sludge storage capacity with improved mixing
10. Upgrade the existing SCADA system
11. Upgrade building HVAC system
12. \*Electrical improvements to include auto transfer capability to the standby generator
13. Improvement to existing administration building to support staff work activities

#### 14. \*Structural, safety, and aesthetic upgrades

##### No. 1 – Headworks Improvements:

Headworks improvements will include installation of a new automatic mechanical fine screen with solids washer and compactor. The new screen will be installed in an addition to the grit building immediately upstream of the grit removal system.

It is proposed to provide a channel overflow arrangement to direct the bulk of flow through the new screen. Peak rate overflows will be by-passed.

##### Grit Removal:

The existing aerated type grit removal process is relatively new and reported to be in excellent condition. Improvements to the existing odor control system, grating, piping and valves and other ancillary items will be included.

##### SCADA and Control Upgrade:

The existing control and monitoring system for the WWTP is digital based and has been upgrade regularly since 1993. A SCADA (Supervisory Control and Data Acquisition) upgrade is recommended under this report. This is needed to incorporate the new primary treatment system, expanded secondary treatment process, include effluent booster pumping, and general upgrades needed. These are aimed at:

- Upgrading process control when significant cost savings result
- Improving reliability by upgrading existing equipment to automatically startup after power failure
- Improving WWTP protection and alarming systems such as high water alarms and security breach

##### Miscellaneous WWTP Improvements:

This includes miscellaneous items regarding work throughout the proposed project that may be altered or needed as part of the final design. The following headings depict the scope of work under the “Miscellaneous” heading.

##### General Concrete Repair:

Miscellaneous locations of concrete and masonry deterioration will be repaired. Repairs normally include chipping away loose concrete and patching with latex modified, Portland cement based patching material. Deteriorated concrete exists at the following locations over the surface areas noted below. Following is additional detail.

#### Painting:

Painting of metal and interior masonry surfaces is needed in some locations throughout the WWTP. Painting of interior masonry, piping, equipment, handrails, and other ferrous metal surfaces is needed to enable the staff to maintain an annual rotation basis. The following painting and (or) coating work is recommended:

- Submerged and intermittently submerged concrete surface of clarifiers, aeration tanks, digesters, and other wastewater storage structures.
- Steel and iron process piping and equipment, interior exposed, exterior exposed, and submerged.
- Interior and exterior exposed ferrous metal surfaces such as handrails, stair stringers, ladders, and frames.
- Interior exposed masonry and concrete surface in occupied areas.

It is recommended that areas of strong need or high difficulty be recoated under this improvement. Areas where existing paint coatings have begun to fail and are difficult to access when other improvements are ongoing, should be completed under a high priority of Phase 1 project. Areas in fair condition and those not requiring intense surface preparation or special cure protection can be continued over time by operating personnel. Painting of wall surface should include protective coating of electrical conduit and equipment.

#### SRF Green Project Reserve:

After reviewing the EGLE Green Project Reserve Guidance document, some of the proposed improvements meet the categorical requirements. Higher efficiency HVAC systems and electrical components may meet the business case requirements. Green Project Reserve information is included in Appendix I.

#### Special Assessment District Projects:

The special assessment district is not applicable to this project.

#### Sensitive Features:

Work will take place on treatment facility grounds and be isolated from any potential sensitive environmental locations. It will be necessary to protect the waters of the Tawas River during construction. Noise and dust must be controlled.

Environmental impacts will be minor and temporary construction related. Mitigation measures as necessary will be required via construction contracts. Permits (along with related agency reviews) will be obtained during the design process. The work will be within 500 feet of a body of water, Tawas River.



Schedule for Design and Construction:

A proposed project schedule Table follows:

**Table 8. Schedule**

Task Description	Planning Date
Letter of Intent	12/2020
TUA Authorizes Project Plan Preparation	9/2020
Project Plan/MDEQ Meeting	12/2020
Complete Formal Draft Project Plan	4/12/21
Advertise for Public Hearing	4/20/21
Hold Public Hearing	5/20/21
Submit SRF Project Plan	6/1/21
Design Begins	6/21 to 10/21
Final Project Priority List Published	10/21
Rate Methodology Approved	10/2022
Submit Part I and II SRF Application	11/2022
Complete Permit	8/2022
FONSI Clearance	10/2022
Design Complete	10/2022
Submit Bid Advertisement	12/2022
Submit Part III SRF Application	2/2023
Notice of Award To Contractor	3/2023
MDEQ Order of Approval	2/2023
SRF Bonds Sold	3/2023
Construction Notice To Proceed	4/2023
Complete Construction	4/2025

Cost Summary:

Table 9 is a summary of construction costs for each recommended improvement. Improvement costs are listed in columns to represent order of priority and potential project phasing.

Construction costs in Table 9 are increased by engineering and contingency allowances to provide total project costs at the bottom. A more detailed breakdown of construction costs is included in Appendix D.

**Table 9. Project Costs**

Description	Cost
Delete Primary Clarifiers	\$20,000
Convert Digesters to Aerobic	\$451,100
Headworks Screening Improvements	\$903,000
Grit System Odor Control	\$556,000
*Rehabilitate Oxidation Ditches	\$274,000
*Secondary Clarifier Rehabilitation	\$329,000
*RAS and WAS Pumping Improvements	\$200,000
Tertiary Filtration	\$1,157,000
*Disinfection Improvements	\$774,000
Effluent Metering	\$33,000
*Sludge Storage and Mixing	\$1,708,000
Building Improvements	\$121,400
Main Building HVAC Improvements	\$102,000
*Electrical Improvements	\$688,000
SCADA System	\$385,00
*Structural Safety and Other Improvements	\$279,000
<b>Subtotal</b>	<b>\$7,980,500</b>
Engineering Planning and Contingencies	\$2,394,200
<b>Total Project Cost, Current Dollars</b>	<b>\$10,374,700</b>
Escalation to 2023, 3% per year	\$622,480
<b>Total Project Cost</b>	<b>\$10,997,180</b>

Those items marked with an asterisk (\*) are those improvements that appear necessary to address the on-going suspended solids and fecal coliform violations. If the project needs to be phased due to costs or other reasons, those items should be constructed as Phase 1. Those items total \$5,859,000.

SRF Eligible Project Funding:

No items to be included in the project are believed to be ineligible for funding under the Michigan SRF program.

### 3.1 Authority to Implement the Selected Alternative

The Tawas Utility Authority is comprised of 50% ownership by both the Cities of Tawas City and East Tawas. The Authority was set up under PA 233 and the Articles of Incorporation provide the authority to both implement the project and to bond for it.

### 3.2 User Costs

The fees and charges imposed by the Tawas Utilities Authority for wastewater treatment comprise only a portion of the end user costs. Each community also adds costs for the operation and maintenance of their individual sewer collection system. The user rates vary between communities.

For the purposes of this project, the user cost increase attributed to the project financing under a CWSRF loan (no principle forgiveness is currently assumed) is estimated as follows:

20 Year Financing:	Cost increase per REU - \$257/year or \$21.45/month
30 Year Financing	Cost increase per REU - \$193/year or \$16.12/month

The user cost increases shown above are for financing of the recommended full, comprehensive project. If the project is to be constructed in phases, and the initial phase consisting of only those items necessary for permit compliance, the user rate increases would be scaled back proportionately.

The above approximation of user rate impacts is based on the current guidelines for bonding rates at 1.875% for 20-year and 2.125% for 30-year terms. The increase in cost for debt service per user is based on a total of 2,500 REUs in the system for the three communities served. The 2,500 REU amount was determined from a review of billing records from each of the three communities served by the TUA. The average usage per REU is 4,400 gallons per month. The TUA provides service to a total of 2,937 customers.

The proposed project includes improvements which involve energy conservation and water use conservation. These components will be submitted to EGLE for funding under the Green Project Reserve. It is possible that principal forgiveness may exist for components which qualify for the Green Project Reserve and should the TUA qualify for Disadvantaged Community Status (see below). These have not been included in the cost analysis, which would effectively reduce the estimated user rate impacts.

### 3.3 Disadvantaged Community

The communities served by the TUA facility were not currently considered a disadvantaged community during the Intent to Apply (ITA) stage. However, as the current cost opinions are significantly higher than in the ITA, and the fact that only the Authority's O&M costs were included in the analysis, it is likely that the TUA may qualify for Disadvantaged Community status and potential principle forgiveness. The current monetary and rate analysis does not include the potential for principle forgiveness (therefore, the rate increase projections are conservative and may be reduced). The Disadvantaged Community status will be reviewed again by EGLE upon the submittal of this Project Plan. An updated Disadvantaged Community Status worksheet is included in Appendix H.

### 3.4 Useful Life

Remaining Useful Life of all wastewater assets is available in 2018 SAW Asset Management Plan. The remaining useful life for WWTP assets is summarize in Appendix F, which is a copy of the Asset Management Plan Summary Sheet.

For new capital improvements including those under the proposed SRF project the total useful lives are as listed below based on methodology for salvage value computation.

- Building: 40 years
- Underground facilities including piping and foundations: 50 years (100 years expected based on performance of existing systems).
- Short-lived equipment: 20 years (30 to 40 years expected based on performance of existing equipment).

Equipment Depreciation and Replacement:

Separated from capital improvements, planning for regular equipment replacement is an important component of plant operations and should be a line item in the budget. Recommendations for annual repair, replacement, and improvement (RRI) of existing short-lived systems was conducted under the 2018 SAW program.

## **CHAPTER 4 – EVALUATION OF ENVIRONMENTAL IMPACTS**

The analysis of environmental impacts includes:

- Direct impacts, which are related to the construction and operation of the project.
- Indirect impacts, which are project induced and/or facilitated.
- Cumulative impacts, which increase in magnitude over time, or which result from individually minor but collectively significant actions occurring over time.

#### 4.1 Analysis of the Impacts

##### Direct Impacts:

- Construction: Minimal to no removal will be necessary for the proposed improvements of the WWTP. The mechanicals upgrades to the secondary clarifiers and the new vortex grit unit will not call for any removal at all. There will be a new screen install that will require a new channel to be constructed; however, the minimal removal is necessary.
- Operational: The WWTP will remain in operation during construction. The odor during construction should remain unchanged due to the nature of the projects taking place.
- Social: The project will likely have no social impacts to the community.

##### Indirect Impacts:

Each improvement will see minimal direct impacts regarding land use, transportation changes, air quality, water quality, natural setting and social resources for the service area. The plant will largely remain the same as minimal removal will need to take place. No tree trimming/removal or other major removal is necessary.

##### Cumulative Impacts:

There will be no adverse cumulative impacts. Each improvement is either a minor addition or a replacement/upgrade to existing features of the plant.

## **CHAPTER 5 – MITIGATION**

Continued suspended solids and fecal coliform permit violations will have a negative impact to the river. To mitigate this issue, the items identified as necessary for the correction of the violations should be constructed as a minimum. In addition, since the WWTP is near the Tawas River, proper SESC measures will be carried out during construction.

### 5.1 Short-Term Construction Related Mitigation

The contract documents will outline requirements for traffic control, safety measures and techniques to accomplish effective dust and noise pollution control, as well as soil erosion and sedimentation control. The soil erosion and sedimentation control plan will include a project schedule, control details, location of surface waters, storm water structures, etc. Site restoration will be coordinated between the site plan and soil erosion control plan, including rebuilding and utilities and restoration.

#### General Construction:

The following measures will be employed during the implementation of each alternative:

- Soil erosion will be minimized through the enforcement of the Soil Erosion and Sedimentation Control Plan.
- Construction operations will be restricted to 7:00 a.m. to 6:00 p.m. to reduce impacts of noise on adjacent residential areas.
- Enforcement of current zoning plans and ordinances will preclude development of sensitive areas, including floodplains, wetlands, and prime/unique farmland.
- Since the WWTP is located in a flood plain, spoils must be disposed of and transported to an offsite location.

#### 5.2 Mitigation of Long-Term Impacts

Construction operations within the floodplain will be controlled by the contract documents to preclude any long term or irreversible impacts. The contract documents will prohibit spoils disposal in adjacent floodplains. Preliminary contacts have been made with authorities to determine the existence, extent, and value of the floodplains and no environmental impact is expected.

#### Siting Decisions:

The WWTP in its entirety is located within a Zone AE floodplain, according to the preceding Figure 5. Proper SESC measures will be performed to maintain floodplain features.

#### Operational Impacts:

The WWTP will remain in operation during construction. The odor during construction should remain unchanged due to the nature of the projects taking place.

#### 5.3 Mitigation of Indirect Impacts

Each project will see minimal direct impacts regarding land use, transportation changes, air quality, water quality, natural setting and social resources for the service area. The proposed improvements will not have a significant impact on the WWTP site or the surrounding area.

#### Master Plan and Zoning:

All work will be performed on and within the WWTP property lines. Historical features, neighborhoods, and prime or unique agricultural lands will not be affected.

**Ordinances:**

There are no ordinances developed for the project.

**Staging of Construction:**

All construction for the proposed project will be staged on site to mitigate traffic and social impacts.

It is the base recommendation of this plan that all of the proposed treatment plant improvements be constructed in one single construction phase. This provides the most cost effective solution over the long term and should minimize the need for any major improvements over the next 20 years. However, if the overall project cost or user cost increases are excessive and deemed not acceptable, the minimum project should be implemented to address the on-going discharge violations in terms of suspended solids and fecal coliform. The minimum phase 1 project should include the following previously described items in some form:

- Safety upgrades
- Disinfection upgrades
- Electrical improvements
- SCADA system upgrades
- RAS/WAS pumping and control upgrades
- Rehabilitate oxidations ditches
- Rehabilitate secondary clarifiers
- Construction additional sludge storage and new mixing system

Operational adjustments and these minimum improvements may provide some minimal timeframe to delay more significant improvements.

## **CHAPTER 6 – PUBLIC PARTICIPATION**

### 6.1 Public Meetings on Project Alternatives

The status of the Project Plan and discussion of alternatives was updated at each monthly TUA board meeting, beginning in November 2020 through April 2021, which are open to the public. Additionally, TUA work sessions to specifically discuss the preliminary draft Project Plan were conducted on April 7 and April 19, 2021. These meetings were also open to the public.



## 6.2 The Formal Public Hearing

A public hearing has been scheduled for Thursday, May 27 at 9 a.m. via Zoom. The public hearing advertisement was published at least 30 days in advance of the hearing. The Affidavit of Publication is included in Appendix E. A verbatim recording of the public hearing has been made.

## 6.3 Comments Received and Answered

No written comments were received within the public comment period. There were no public attendees at the public hearing and therefore no questions asked/answered during the public hearing.

## 6.4 Adoption of the Project Plan

The public hearing was conducted via Zoom and in-person on May 27, 2021 as advertised. After completion of the public hearing the Project Plan was adopted by the TUA. A resolution of adoption of the Project Plan is included in Appendix E.

## **APPENDIX A**

### **PREVIOUS REPORTS**

Previous Reports

**Table 1. Resource Documents**

Document Name	Origin	Date of Document
Facility Condition May-June 2013	Fleis & Vandenbrink	8/28/2019
2016 Influent Data	TUA WWTP	7/24/2020
2017 Influent Data	TUA WWTP	7/24/2020
2018 Influent Data	TUA WWTP	7/24/2020
2019 Influent Data	TUA WWTP	7/24/2020
SAW Wastewater Treatment Plan Asset Management Plan Executive Summary	Fleis & Vandenbrink	11/2020
Asset Management Plan Mass Flow Monitoring East Tawas	Fleis & Vandenbrink	3/2018
Asset Management Plan Mass Flow Monitoring City of Tawas City	Fleis & Vandenbrink	2/2019
TUA Wastewater Treatment Plant Asset Management Plan	Fleis & Vandenbrink	3/16/2017
TUA Wastewater Treatment Plant Asset Management Plan Annual Report	Fleis & Vandenbrink	7/2019
TUA Sewer Rates Letter to Baldwin Township Board	TUA	12/12/2019
2020 Baldwin Township Water/Sewer Rates	TUA	8/1/2020
BioTech Agronomics, Inc. Contract for Testing, Removal & Land Application of Biosolids from the TUA Wastewater Treatment Plant	Fleis & Vandenbrink	1/28/2020
Fleis & Vandenbrink TUA Wastewater Treatment Facility Power Point Presentation – Background, WWTP Overview, Facility Condition Assessment & Capital Improvement Plan, Next Steps, Plant Tour	Fleis & Vandenbrink	10/14/2019
MDEQ TUA Violation Notice VN-005542	MDEQ	4/10/2013
MDEQ TUA Violation Notice VN-005877	MDEQ	7/17/2014
TUA Wholesale Rate Analysis	C2AE	2/2010
EGLE SAW WWTP Certificate of Completion	EGLE	5/2019
City of Tawas City Resoluitiion for Water & Sewer Rates, Fees, Surcharges, & Special Charges	City of Tawas City	6/1/2020
City of East Tawas Sewer Rate Resolution	City of East Tawas	6/1/2020
TUSA Budget Report 2006-2019	TUA	2019
TUA WWTP Operations & Maintenance Manual	TUA	11/2010
Plan of Operation East Tawas – Tawas City Wastewater Treatment Plant	TUA	8/1988

## **APPENDIX B**

### **NPDES PERMIT & COMPLIANCE NOTICES**

PERMIT NO. MI0021091

  
**STATE OF MICHIGAN**  
**DEPARTMENT OF ENVIRONMENT, GREAT LAKES,**  
**AND ENERGY**

**AUTHORIZATION TO DISCHARGE UNDER THE  
NATIONAL POLLUTANT DISCHARGE ELIMINATION SYSTEM**

In compliance with the provisions of the federal Clean Water Act (federal Water Pollution Control Act, 33 U.S.C., Section 1251 *et seq.*, as amended); Part 31, Water Resources Protection, of the Natural Resources and Environmental Protection Act, 1994 PA 451, as amended (NREPA); Part 41, Sewerage Systems, of the NREPA; and Michigan Executive Order 2019-06,

**Tawas Utility Authority**  
760 Newman Street  
PO Box 672  
East Tawas, MI 48730

is authorized to discharge from the **Tawas Utility Authority Wastewater Treatment Plant** located at

810 West Franklin Street  
East Tawas, MI 48730

designated as **Tawas Utility Authority WWTP**

to the receiving water named the Tawas River in accordance with effluent limitations, monitoring requirements, and other conditions set forth in this permit.

This permit is based on a complete application submitted on April 4, 2017.

**This permit takes effect on June 1, 2020.** The provisions of this permit are severable. After notice and opportunity for a hearing, this permit may be modified, suspended, or revoked in whole or in part during its term in accordance with applicable laws and rules. On its effective date, this permit shall supersede National Pollutant Discharge Elimination System (NPDES) Permit No. MI0021091 (expiring October 1, 2017).

This permit and the authorization to discharge shall expire at midnight on **October 1, 2024**. In order to receive authorization to discharge beyond the date of expiration, the permittee shall submit an application that contains such information, forms, and fees as are required by the Michigan Department of Environment, Great Lakes, and Energy (Department) by **April 4, 2024**.

**Issued:** April 29, 2020

Original signed by Christine Alexander  
Christine Alexander, Manager  
Permits Section  
Water Resources Division

## PERMIT FEE REQUIREMENTS

In accordance with Section 324.3120 of the NREPA, the permittee shall make payment of an annual permit fee to the Department for each October 1 the permit is in effect regardless of occurrence of discharge. The permittee shall submit the fee in response to the Department's annual notice. Payment may be made electronically via the Department's MiWaters system. The MiWaters website is located at <https://miwaters.deq.state.mi.us>. Payment shall be submitted or postmarked by January 15 for notices mailed by December 1. Payment shall be submitted or postmarked no later than 45 days after receiving the notice for notices mailed after December 1.

**Annual Permit Fee Classification:** Municipal Major, less than 10 MGD (Individual Permit)

In accordance with Section 324.3118 of the NREPA, the permittee shall make payment of an annual storm water fee to the Department for each January 1 the permit is in effect regardless of occurrence of discharge. The permittee shall submit the fee in response to the Department's annual notice. Payment may be made electronically via the Department's MiWaters system. The MiWaters website is located at <https://miwaters.deq.state.mi.us>. Payment shall be submitted or postmarked by March 15 for notices mailed by February 1. Payment shall be submitted or postmarked no later than 45 days after receiving the notice for notices mailed after February 1.

In accordance with Section 324.3132 of the NREPA, the permittee shall make payment of an annual biosolids land application fee to the Department if the permittee land applies biosolids. The permittee shall submit the fee in response to the Department's annual notice. Payment may be made electronically via the Department's MiWaters system. The MiWaters website is located at <https://miwaters.deq.state.mi.us>. Payment shall be submitted or postmarked no later than January 31 of each year for notices mailed by December 15. Payment shall be submitted or postmarked no later than 45 days after receiving the notice for notices mailed after December 15.

## CONTACT INFORMATION

Unless specified otherwise, all contact with the Department required by this permit shall be made to the Bay City District Office of the Water Resources Division. The Bay City District Office is located at 401 Ketchum Street, Suite B, Bay City, MI, 48708-5430, Telephone: 989-894-6200, Fax: 989-891-9237.

## CONTESTED CASE INFORMATION

Any person who is aggrieved by this permit may file a sworn petition with the Michigan Administrative Hearing System within the Michigan Department of Licensing and Regulatory Affairs, c/o the Michigan Department of Environment, Great Lakes, and Energy, setting forth the conditions of the permit which are being challenged and specifying the grounds for the challenge. The Department of Licensing and Regulatory Affairs may reject any petition filed more than 60 days after issuance as being untimely.

**PART I**

**Section A. Limitations and Monitoring Requirements**

**1. Final Effluent Limitations, Monitoring Point 001A**

During the period beginning on the effective date of this permit and lasting until the expiration date of this permit, the permittee is authorized to discharge treated municipal wastewater from Monitoring Point 001A through Outfall 001. Outfall 001 discharges to the Tawas River at Latitude 44.2834, Longitude -83.5048. Such discharge shall be limited and monitored by the permittee as specified below.

Parameter	Maximum Limits for Quantity or Loading				Maximum Limits for Quality or Concentration				Monitoring Frequency	Sample Type
	Monthly	7-Day	Daily	Units	Monthly	7-Day	Daily	Units		
Flow	(report)	---	(report)	MGD	---	---	---	---	Daily	Report Total Daily Flow
Carbonaceous Biochemical Oxygen Demand (CBOD5)										
	500	800	(report)	lbs/day	25	40	(report)	mg/l	3x Weekly	24-Hr Composite
Total Suspended Solids (TSS)										
	600	900	(report)	lbs/day	30	45	(report)	mg/l	3x Weekly	24-Hr Composite
Ammonia Nitrogen (as N)										
June – August	180	---	(report)	lbs/day	8.8	---	(report)	mg/l	3x Weekly	24-Hr Composite
September – October	280	---	(report)	lbs/day	14	---	(report)	mg/l	3x Weekly	24-Hr Composite
November – May	(report)	---	(report)	lbs/day	(report)	---	(report)	mg/l	3x Weekly	24-Hr Composite
Total Phosphorus (as P)	20	---	(report)	lbs/day	1.0	---	(report)	mg/l	3x Weekly	24-Hr Composite
Fecal Coliform Bacteria	---	---	---	---	200	400	(report)	cts/100 ml	3x Weekly	Grab
Total Residual Chlorine	---	---	---	---	---	---	38	ug/l	Daily	Grab
Perfluorooctane sulfonate (PFOS)										
	(report)	---	(report)	lbs/day	(report)	---	(report)	ng/l	Quarterly	Grab
Perfluorooctanoic acid (PFOA)										
	(report)	---	(report)	lbs/day	(report)	---	(report)	ug/l	Quarterly	Grab
Total Mercury										
Corrected	(report)	---	(report)	lbs/day	(report)	---	(report)	ng/l	Quarterly	Calculation
Uncorrected	---	---	---	---	---	---	(report)	ng/l	Quarterly	Grab
Field Duplicate	---	---	---	---	---	---	(report)	ng/l	Quarterly	Grab
Field Blank	---	---	---	---	---	---	(report)	ng/l	Quarterly	Preparation
Laboratory Method Blank	---	---	---	---	---	---	(report)	ng/l	Quarterly	Preparation
	<b>12-Month Rolling Avg</b>				<b>12-Month Rolling Avg</b>					
Total Mercury	0.00004	---	---	lbs/day	2.0	---	---	ng/l	Quarterly	Calculation



Parameter	Maximum Limits for Quantity or Loading				Maximum Limits for Quality or Concentration				Monitoring Frequency	Sample Type
	Monthly	7-Day			Monthly	7-Day	Daily	Units		
					Minimum % Monthly		Minimum % Daily			
CBOD5 Minimum % Removal	---	---	---	---	85	---	(report)	%	Monthly	Calculation
TSS Minimum % Removal	---	---	---	---	85	---	(report)	%	Monthly	Calculation
					Minimum Daily		Maximum Daily			
pH	---	---	---	---	6.5	---	9.0	S.U.	Daily	Grab
Dissolved Oxygen	---	---	---	---	4.0	---	---	mg/l	3x Weekly	Grab

The following design flow was used in determining the above limitations, but is not to be considered a limitation or actual capacity: 2.4 MGD

- a. **Narrative Standard**  
The receiving water shall contain no turbidity, color, oil films, floating solids, foams, settleable solids, or deposits as a result of this discharge in unnatural quantities which are or may become injurious to any designated use.
- b. **Sampling Locations**  
Samples for CBOD5, TSS, Ammonia Nitrogen, Total Phosphorus, Fecal Coliform Bacteria, Total Residual Chlorine, Total Mercury, Perfluorooctane Sulfonate, Perfluorooctanoic Acid and pH shall be taken after disinfection based on an alternate sampling location previously approved by the Department. The Department may approve alternate sampling locations that are demonstrated by the permittee to be representative of the effluent.
- c. **Quarterly Monitoring**  
Quarterly samples shall be taken during the months of January, April, July, and October. If the facility does not discharge during these months, the permittee shall sample the next discharge occurring during the period in question. If the facility does not discharge during the period in question, a sample is not required for that period. For any month in which a sample is not taken, the permittee shall enter “\*G” on the Discharge Monitoring Report (DMR). (For purposes of reporting on the Daily tab of the DMR, the permittee shall enter “\*G” on the first day of the month only).
- d. **Total Residual Chlorine (TRC)**  
Compliance with the TRC limit shall be determined on the basis of one (1) or more grab samples. If more than one (1) sample per day is taken, the additional samples shall be collected in near equal intervals over at least eight (8) hours. The samples shall be analyzed immediately upon collection and the average reported as the daily concentration. Samples shall be analyzed in accordance with Part II.B.2. of this permit.
- e. **Percent Removal Requirements**  
Monthly percent removal shall be calculated based on the monthly average effluent CBOD5 and TSS concentrations and the monthly average influent concentrations for approximately the same period. Daily percent removal shall be calculated based on the daily effluent CBOD5 and TSS concentrations and the daily influent concentrations for the same day. Reporting of Daily percent removal is only required on days on which an influent sample is obtained.

## f. Final Effluent Limitation for Total Mercury

The final limit for total mercury is the Discharge Specific Level Currently Achievable (LCA) based on a multiple discharger variance from the WQBEL of 1.3 ng/l, pursuant to Rule 1103(9) of the Water Quality Standards. Compliance with the LCA shall be determined as a 12-month rolling average, the calculation of which may be done using blank-corrected sample results. The 12-month rolling average shall be determined by adding the present monthly average result to the preceding 11 monthly average results then dividing the sum by 12. For facilities with quarterly monitoring requirements for total mercury, quarterly monitoring shall be equivalent to three (3) months of monitoring in calculating the 12-month rolling average. Facilities that monitor more frequently than monthly for total mercury must determine the monthly average result, which is the sum of the results of all data obtained in a given month divided by the total number of samples taken, in order to calculate the 12-month rolling average. If the 12-month rolling average for any quarter is less than or equal to the LCA, the permittee will be considered to be in compliance for total mercury for that quarter, provided the permittee is also in full compliance with the Pollutant Minimization Program for Total Mercury, set forth in Part I.A.4. of this permit.

After a minimum of 10 quarterly data points have been collected, the permittee may request a reduction in the monitoring frequency for total mercury. This request shall contain an explanation as to why the reduced monitoring is appropriate and shall be submitted to the Department. Upon receipt of written approval and consistent with such approval, the permittee may reduce the monitoring frequency for total mercury indicated in Part I.A.1. of this permit. The monitoring frequency shall not be reduced to less than annually. The Department may revoke the approval for reduced monitoring at any time upon notification to the permittee.

## g. Total Mercury Testing and Additional Reporting Requirements

The analytical protocol for total mercury shall be in accordance with EPA Method 1631, Revision E, "Mercury in Water by Oxidation, Purge and Trap, and Cold Vapor Atomic Fluorescence Spectrometry," EPA-821-R-02-019, August 2002. The quantification level for total mercury shall be 0.5 ng/l, unless a higher level is appropriate because of sample matrix interference. Justification for higher quantification levels shall be submitted to the Department within 30 days of such determination.

The use of clean technique sampling procedures is required unless the permittee can demonstrate to the Department that an alternate sampling procedure is representative of the discharge. Guidance for clean technique sampling is contained in EPA Method 1669, "Sampling Ambient Water for Trace Metals at EPA Water Quality Criteria Levels (Sampling Guidance)," EPA-821-R96-001, July 1996. Information and data documenting the permittee's sampling and analytical protocols and data acceptability shall be submitted to the Department upon request.

In order to demonstrate compliance with EPA Method 1631E and EPA Method 1669, the permittee shall report, on the daily sheet, the analytical results of all field blanks and field duplicates collected in conjunction with each sampling event, as well as laboratory method blanks when used for blank correction. The permittee shall collect at least one (1) field blank and at least one (1) field duplicate per sampling event. If more than ten (10) samples are collected during a sampling event, the permittee shall collect at least one (1) additional field blank AND field duplicate for every ten (10) samples collected. Only field blanks or laboratory method blanks may be used to calculate a concentration lower than the actual sample analytical results (i.e., a blank correction). Only one (1) blank (field OR laboratory method) may be used for blank correction of a given sample result, and only if the blank meets the quality control acceptance criteria. If blank correction is not performed on a given sample analytical result, the permittee shall report under "Total Mercury – Corrected" the same value reported under "Total Mercury – Uncorrected." The field duplicate is for quality control purposes only; its analytical result shall not be averaged with the sample result.

- h. Monitoring Frequency Reduction for Perfluorooctane Sulfonate (PFOS) and/or Perfluorooctanoic Acid (PFOA)

After the submittal of 48 months of Quarterly data or at least 10 equally spaced sample results obtained over a minimum of three (3) months, the permittee may request, in writing, Department approval of a reduction in monitoring frequency for PFOS and/or PFOA. This request shall contain an explanation as to why the reduced monitoring is appropriate. Upon receipt of written approval and consistent with such approval, the permittee may reduce the monitoring frequency indicated in Part I.A.1. of this permit. The monitoring frequency for PFOS and/or PFOA shall not be reduced to less than annually. The Department may revoke the approval for reduced monitoring at any time upon notification to the permittee.

## 2. Quantification Levels and Analytical Methods for Selected Parameters

Quantification levels (QLs) are specified for selected parameters in the table below. These QLs shall be considered the maximum acceptable unless a higher QL is appropriate because of sample matrix interference. Justification for higher QLs shall be submitted to the Department within 30 days of such determination. Where necessary to help ensure that the QLs specified can be achieved, analytical methods may also be specified in the table below. The sampling procedures, preservation and handling, and analytical protocol for all monitoring conducted in compliance with this permit, including monitoring conducted to meet the requirements of the application for permit reissuance, shall be in accordance with the methods specified in the table below, or in accordance with Part II.B.2. of this permit if no method is specified in the table below, unless an alternate method is approved by the Department. **Not all QLs are expressed in the same units in the table below.** The table is continued on the following page:

Parameter	QL	Units	Analytical Method
1,2-Diphenylhydrazine (as Azobenzene)	3.0	ug/l	
2,4,6-Trichlorophenol	5.0	ug/l	
2,4-Dinitrophenol	19	ug/l	
3,3'-Dichlorobenzidine	1.5	ug/l	EPA Method 605
4-Chloro-3-Methylphenol	7.0	ug/l	
4,4'-DDD	0.01	ug/l	EPA Method 608
4,4'-DDE	0.01	ug/l	EPA Method 608
4,4'-DDT	0.01	ug/l	EPA Method 608
Acrylonitrile	1.0	ug/l	
Aldrin	0.01	ug/l	EPA Method 608
Alpha-Endosulfan	0.01	ug/l	EPA Method 608
Alpha-Hexachlorocyclohexane	0.01	ug/l	EPA Method 608
Antimony, Total	1	ug/l	
Arsenic, Total	1	ug/l	
Barium, Total	5	ug/l	
Benzidine	0.1	ug/l	EPA Method 605
Beryllium, Total	1	ug/l	
Beta-Endosulfan	0.01	ug/l	EPA Method 608
Beta-Hexachlorocyclohexane	0.01	ug/l	EPA Method 608
Bis (2-Chloroethyl) Ether	1.0	ug/l	
Bis (2-Ethylhexyl) Phthalate	5.0	ug/l	
Boron, Total	20	ug/l	
Cadmium, Total	0.2	ug/l	
Chlordane	0.01	ug/l	EPA Method 608
Chloride	1.0	mg/l	
Chromium, Hexavalent	5	ug/l	

Parameter	QL	Units	Analytical Method
Chromium, Total	10	ug/l	
Copper, Total	1	ug/l	
Cyanide, Available	2	ug/l	EPA Method OIA 1677
Cyanide, Total	5	ug/l	
Delta-Hexachlorocyclohexane	0.01	ug/l	EPA Method 608
Dieldrin	0.01	ug/l	EPA Method 608
Di-N-Butyl Phthalate	9.0	ug/l	
Endosulfan Sulfate	0.01	ug/l	EPA Method 608
Endrin	0.01	ug/l	EPA Method 608
Endrin Aldehyde	0.01	ug/l	EPA Method 608
Fluoranthene	1.0	ug/l	
Heptachlor	0.01	ug/l	EPA Method 608
Heptachlor Epoxide	0.01	ug/l	EPA Method 608
Hexachlorobenzene	0.01	ug/l	EPA Method 612
Hexachlorobutadiene	0.01	ug/l	EPA Method 612
Hexachlorocyclopentadiene	0.01	ug/l	EPA Method 612
Hexachloroethane	5.0	ug/l	
Lead, Total	1	ug/l	
Lindane	0.01	ug/l	EPA Method 608
Lithium, Total	10	ug/l	
Mercury, Total	0.5	ng/l	EPA Method 1631E
Nickel, Total	5	ug/l	
PCB-1016	0.1	ug/l	EPA Method 608
PCB-1221	0.1	ug/l	EPA Method 608
PCB-1232	0.1	ug/l	EPA Method 608
PCB-1242	0.1	ug/l	EPA Method 608
PCB-1248	0.1	ug/l	EPA Method 608
PCB-1254	0.1	ug/l	EPA Method 608
PCB-1260	0.1	ug/l	EPA Method 608
Pentachlorophenol	1.8	ug/l	
Perfluorooctane sulfonate (PFOS)	2.0	ng/l	ASTM D7979 or an isotope dilution method (sometimes referred to as Method 537 modified)
Perfluorooctanoic acid (PFOA)	0.002	ug/l	ASTM D7979 or an isotope dilution method (sometimes referred to as Method 537 modified)
Phenanthrene	1.0	ug/l	
Phosphorus (as P), Total	10	ug/l	
Selenium, Total	1.0	ug/l	
Silver, Total	0.5	ug/l	
Strontium, Total	1000	ug/l	
Sulfate	2.0	mg/l	
Sulfides, Dissolved	20	ug/l	
Thallium, Total	1	ug/l	
Toxaphene	0.1	ug/l	EPA Method 608
Vinyl Chloride	1.0	ug/l	
Zinc, Total	10	ug/l	



Base/Neutral Compounds

acenaphthene	acenaphthylene	anthracene	benzidine
benzo(a)anthracene	benzo(a)pyrene	3,4-benzofluoranthene	benzo(ghi)perylene
benzo(k)fluoranthene	bis(2-chloroethoxy)methane	bis(2-chloroethyl)ether	bis(2-chloroisopropyl)ether
bis(2-ethylhexyl)phthalate	4-bromophenyl phenyl ether	butyl benzyl phthalate	2-chloronaphthalene
4-chlorophenyl phenyl ether	chrysene	di-n-butyl phthalate	di-n-octyl phthalate
dibenzo(a,h)anthracene	1,2-dichlorobenzene	1,3-dichlorobenzene	1,4-dichlorobenzene
3,3'-dichlorobenzidine	diethyl phthalate	dimethyl phthalate	2,4-dinitrotoluene
2,6-dinitrotoluene	1,2-diphenylhydrazine	fluoranthene	fluorene
Hexachlorobenzene	hexachlorobutadiene	hexachlorocyclo-pentadiene	hexachloroethane
indeno(1,2,3-cd)pyrene	isophorone	naphthalene	nitrobenzene
n-nitrosodi-n-propylamine	n-nitrosodimethylamine	n-nitrosodiphenylamine	phenanthrene
pyrene	1,2,4-trichlorobenzene		

#### 4. Pollutant Minimization Program for Total Mercury

The goal of the Pollutant Minimization Program is to maintain the effluent concentration of total mercury at or below 1.3 ng/l. The permittee shall continue to implement the Pollutant Minimization Program approved on December 16, 2007, and modifications thereto, to proceed toward the goal. The Pollutant Minimization Program includes the following:

- a. an annual review and semi-annual monitoring of potential sources of mercury entering the wastewater collection system;
- b. a program for quarterly monitoring of influent and periodic monitoring of sludge for mercury; and
- c. implementation of reasonable cost-effective control measures when sources of mercury are discovered. Factors to be considered include significance of sources, economic considerations, and technical and treatability considerations.

On or before March 31 of each year, the permittee shall submit a status report to the Department for the previous calendar year that includes 1) the monitoring results for the previous year, 2) an updated list of potential mercury sources, and 3) a summary of all actions taken to reduce or eliminate identified sources of mercury.

Any information generated as a result of the Pollutant Minimization Program set forth in this permit may be used to support a request to modify the approved program or to demonstrate that the Pollutant Minimization Program requirement has been completed satisfactorily.

A request for modification of the approved program and supporting documentation shall be submitted in writing to the Department for review and approval. The Department may approve modifications to the approved program (approval of a program modification does not require a permit modification), including a reduction in the frequency of the requirements under items a. and b. above.

This permit may be modified in accordance with applicable laws and rules to include additional mercury conditions and/or limitations as necessary.

## 5. Pollutant Minimization and Source Evaluation Program for Perfluorooctane Sulfonate (PFOS) and/or Perfluorooctanoic Acid (PFOA)

The goal of the Pollutant Minimization and Source Evaluation Program is to identify and address sources of PFOS and/or PFOA and to reduce and maintain the effluent concentrations of PFOS and/or PFOA at or below the water quality-based effluent limitations (WQBELs). The WQBELs are 12 ng/l PFOS and 63 ug/l for PFOA.

On or before September 1, 2020 the permittee shall submit an approvable Pollutant Minimization and Source Evaluation Program for PFOS and/or PFOA to proceed toward the goal. The Pollutant Minimization and Source Evaluation Program shall continue work under the IPP Interim Initiative and shall include the following at a minimum:

- a. identification of and strategies to identify any additional potential and probable PFOS and/or PFOA sources;
- b. monitoring plan for the permitted facility's influent and effluent and effluent from potential sources;
- c. implemented measures thus far to eliminate, reduce, and/or control sources, and an assessment of the degree of success and the strategies used to measure success; and
- d. proposed measures and implementation schedules for elimination, control, and/or reduction of the identified sources (prioritizing highest loadings and concentrations), and the strategies that will be used to measure success.

The Pollutant Minimization and Source Evaluation Program shall be implemented upon approval by the Department.

On or before May 1 of each year following Pollutant Minimization and Source Evaluation Program implementation, the permittee shall submit to the Department a status report for the previous calendar year. Upon written notification by the Department, the permittee may be required to submit more frequent status reports. Status reports at a minimum shall include:

- a. complete listing of PFOS and/or PFOA sources;
- b. summary of influent and effluent monitoring data;
- c. summary of monitoring data from known or potential sources;
- d. history and compliance status for sources;
- e. implemented measures to eliminate, reduce, or control sources, (prioritizing highest loadings and concentrations), and an assessment of the degree of success and the strategies used to measure success;
- f. proposed measures and schedules for elimination, control, or reduction of any newly identified PFOS and/or PFOA sources (prioritizing highest loadings and concentrations), and the strategies that will be used to measure success;
- g. barriers to implementation and revisions to the implementation schedule; and
- h. laboratory reports, if not previously supplied.

Any information generated as a result of the Pollutant Minimization and Source Evaluation Program set forth in this permit may be used to support a request to modify the Pollutant Minimization and Source Evaluation Program or to demonstrate that the requirement has been completed satisfactorily.

A request for modification of the approved Pollutant Minimization and Source Evaluation Program shall be submitted in writing to the Department along with supporting documentation for review and approval. The Department may approve modifications to the approved Pollutant Minimization and Source Evaluation Program, including a reduction in the frequency of the influent and known or potential source monitoring requirements. Approval of a Pollutant Minimization and Source Evaluation Program modification does not require a permit modification.



This permit may be modified in accordance with applicable laws and rules to include additional PFOS and/or PFOA conditions and/or limitations as necessary.

## 6. Untreated or Partially Treated Sewage Discharge Reporting and Testing Requirements

In accordance with Section 324.3112a of the NREPA, if untreated or partially treated sewage is directly or indirectly discharged from a sewer system onto land or into the waters of the state, the permittee shall immediately, but not more than 24 hours after the discharge begins, notify local health departments, a daily newspaper of general circulation in the county in which the permittee is located, and a daily newspaper of general circulation in the county or counties in which the municipalities whose waters may be affected by the discharge are located, that the discharge is occurring. The permittee shall also notify the Department via its MiWaters system on the form entitled "Report of Discharge (CSO\SSO\RTB)." The MiWaters website is located at <https://miwaters.deq.state.mi.us>. At the conclusion of the discharge, the permittee shall make all such notifications specified in, and in accordance with, Section 324.3112a of the NREPA, and shall notify the Department via its MiWaters system on the form entitled "Report of Discharge (CSO\SSO\RTB)."

The permittee shall also annually contact municipalities, including the superintendent of a public drinking water supply with potentially affected intakes, whose waters may be affected by the permittee's discharge of untreated or partially treated sewage, and if those municipalities wish to be notified in the same manner as specified above, the permittee shall provide such notification.

Additionally, in accordance with Section 324.3112a of the NREPA, each time a discharge of untreated or partially treated sewage occurs, the permittee shall test the affected waters for *Escherichia coli* to assess the risk to the public health as a result of the discharge and shall provide the test results to the affected local county health departments and to the Department. The results of this testing shall be submitted to the Department via MiWaters as part of the notification specified above, or, if the results are not yet available, submitted as soon as they become available. This testing is not required if it has been waived by the local health department, or if the discharge(s) did not affect surface waters. The testing shall be done at locations specified by each affected local county health department but shall not exceed 10 tests for each separate discharge event. The affected local county health department may waive this testing requirement if it determines that such testing is not needed to assess the risk to the public health as a result of the discharge event.

Permittees accepting sanitary or municipal sewage from other sewage collection systems are encouraged to notify the owners of those systems of the above reporting and testing requirements.

## 7. Facility Contact

The "Facility Contact" was specified in the application. The permittee may replace the facility contact at any time, and shall notify the Department in writing within 10 days after replacement (including the name, address and telephone number of the new facility contact).

- a. The facility contact shall be (or a duly authorized representative of this person):
  - for a corporation, a principal executive officer of at least the level of vice president; or a designated representative if the representative is responsible for the overall operation of the facility from which the discharge originates, as described in the permit application or other NPDES form,
  - for a partnership, a general partner,
  - for a sole proprietorship, the proprietor, or
  - for a municipal, state, or other public facility, either a principal executive officer, the mayor, village president, city or village manager or other duly authorized employee.

- b. A person is a duly authorized representative only if:
- the authorization is made in writing to the Department by a person described in paragraph a. of this section; and
  - the authorization specifies either an individual or a position having responsibility for the overall operation of the regulated facility or activity such as the position of plant manager, operator of a well or a well field, superintendent, position of equivalent responsibility, or an individual or position having overall responsibility for environmental matters for the facility (a duly authorized representative may thus be either a named individual or any individual occupying a named position).

Nothing in this section releases the permittee from properly submitting reports and forms as required by law.

## 8. Monthly Operating Reports

Part 41 of Act 451 of 1994 as amended, specifically Section 324.4106 and associated R 299.2953, requires that the permittee file with the Department, on forms prescribed by the Department, operating reports showing the effectiveness of the treatment facility operation and the quantity and quality of liquid wastes discharged into waters of the state.

Within 30 days of the effective date of this permit, the permittee shall submit to the Department a revised treatment facility monitoring program to address monitoring requirement changes reflected in this permit, or submit justification explaining why monitoring requirement changes reflected in this permit do not necessitate revisions to the treatment facility monitoring program. The permittee shall implement the revised treatment facility monitoring program upon approval from the Department. Applicable forms and guidance are available on the Department's web site at [https://www.michigan.gov/egle/0,9429,7-135-3313\\_71618\\_44117---,00.html](https://www.michigan.gov/egle/0,9429,7-135-3313_71618_44117---,00.html). The permittee may use alternate forms if they are consistent with the approved treatment facility monitoring program. Unless the Department provides written notification to the permittee that monthly submittal of operating reports is required, operating reports that result from implementation of the approved treatment facility monitoring program shall be maintained on site for a minimum of three (3) years and shall be made available to the Department for review upon request.

## 9. Asset Management

The permittee shall at all times properly operate and maintain all facilities (i.e., the sewer system and treatment works as defined in Part 41 of the NREPA), and control systems installed or used by the permittee to operate the sewer system and treatment works and achieve and maintain compliance with the conditions of this permit (also see Part II.D.3 of this permit). The requirements of an Asset Management Program function to achieve the goals of effective performance, adequate funding, and adequate operator staffing and training. Asset management is a planning process for ensuring that optimum value is gained for each asset and that financial resources are available to rehabilitate and replace those assets when necessary. Asset management is centered on a framework of five (5) core elements: the current state of the assets; the required sustainable level of service; the assets critical to sustained performance; the minimum life-cycle costs; and the best long-term funding strategy.

a. Asset Management Program Requirements

The permittee shall continue to implement the Asset Management Plan approved on February 2, 2019, and approved modifications thereto. The Asset Management Plan contains a schedule for the development and implementation of an Asset Management Program that meets the requirements outlined below in 1) – 4):

1) *Maintenance Staff.* The permittee shall provide an adequate staff to carry out the operation, maintenance, repair, and testing functions required to ensure compliance with the terms and conditions of this permit. The level of staffing needed shall be determined by taking into account the work involved in operating the sewer system and treatment works, planning for and conducting maintenance, and complying with this permit.

2) *Collection System Map.* The permittee shall complete a map of the sewer collection system it owns and operates. The map shall be of sufficient detail and at a scale to allow easy interpretation.

The collection system information shown on the map shall be based on current conditions and shall be kept up-to-date and available for review by the Department. **Note: Items below referencing combined sewer systems are not applicable to separate sewer systems.** Such map(s) shall include but not be limited to the following:

- a) all sanitary sewer lines and related manholes;
- b) all combined sewer lines, related manholes, catch basins and CSO regulators;
- c) all known or suspected connections between the sanitary sewer or combined sewer and storm drain systems;
- d) all outfalls, including the treatment plant outfall(s), combined sewer treatment facility outfalls, untreated CSOs, and any known SSOs;
- e) all pump stations and force mains;
- f) the wastewater treatment facility(ies), including all treatment processes;
- g) all surface waters (labeled);
- h) other major appurtenances such as inverted siphons and air release valves;
- i) a numbering system which uniquely identifies manholes, catch basins, overflow points, regulators and outfalls;
- j) the scale and a north arrow;
- k) the pipe diameter, date of installation, type of material, distance between manholes, and the direction of flow; and
- l) the manhole interior material, rim elevation (optional), and invert elevations.

3) *Inventory and assessment of fixed assets.* The permittee shall complete an inventory and assessment of operations-related fixed assets including portions of the collection system owned and operated by the permittee. Fixed assets are assets that are normally stationary (e.g., pumps, blowers, buildings, manholes, and sewer lines). The inventory and assessment shall be based on current conditions and shall be kept up-to-date and available for review by the Department.

- a) The fixed asset inventory shall include the following:
  - (1) a brief description of the fixed asset, its design capacity (e.g., pump: 120 gallons per minute), its level of redundancy, and its tag number if applicable;
  - (2) the location of the fixed asset;
  - (3) the year the fixed asset was installed;
  - (4) the present condition of the fixed asset (e.g., excellent, good, fair, poor); and
  - (5) the current fixed asset (replacement) cost in dollars for year specified in accordance with approved schedules;
- b) The fixed asset assessment shall include a "Business Risk Evaluation" that combines the probability of failure of the fixed asset and the criticality of the fixed asset, as follows:
  - (1) Rate the probability of failure of the fixed asset on a scale of 1-5 (low to high) using criteria such as maintenance history, failure history, and remaining percentage of useful life (or years remaining);

(2) Rate the criticality of the fixed asset on a scale of 1-5 (low to high) based on the consequence of failure versus the desired level of service for the facility; and

(3) Compute the Business Risk Factor of the fixed asset by multiplying the failure rating from (1) by the criticality rating from (2).

4) *Operation, Maintenance & Replacement (OM&R) Budget and Rate Sufficiency for the Sewer System and Treatment Works.* The permittee shall complete an assessment of its user rates and replacement fund, including the following:

- a) beginning and end dates of fiscal year;
- b) name of the department, committee, board, or other organization that sets rates for the operation of the sewer system and treatment works;
- c) amount in the permittee's replacement fund in dollars for year specified in accordance with approved schedules;
- d) replacement fund strategy of all assets with a useful life of 20 years or less;
- e) expenditures for maintenance, corrective action and capital improvement taken during the fiscal year;
- f) OM&R budget for the fiscal year; and
- g) rate calculation demonstrating sufficient revenues to cover OM&R expenses. If the rate calculation shows there are insufficient revenues to cover OM&R expenses, the permittee shall document, within three (3) fiscal years after submittal of the Asset Management Plan, that there is at least one rate adjustment that reduces the revenue gap by at least 10 percent. The permittee may prepare and submit an alternate plan, subject to Department approval, for addressing the revenue gap. The ultimate goal of the Asset Management Program is to ensure sufficient revenues to cover OM&R expenses.

b. Annual Reporting

The permittee shall develop a written report that summarizes asset management activities completed during the previous year and planned for the upcoming year. The written report shall be submitted to the Department on or before August 1 of each year. The written report shall include:

- 1) a description of the staffing levels maintained during the year;
- 2) a description of inspections and maintenance activities conducted and corrective actions taken during the previous year;
- 3) expenditures for collection system maintenance activities, treatment works maintenance activities, corrective actions, and capital improvement during the previous year;
- 4) a summary of assets/areas identified for inspection/action (including capital improvement) in the upcoming year based on the five (5) core elements and the Business Risk Factors computed in accordance with condition a.3)b)(3) above;
- 5) a maintenance budget and capital improvement budget for the upcoming year that take into account implementation of an effective Asset Management Program that meets the five (5) core elements;
- 6) an updated asset inventory based on the original submission; and
- 7) an updated OM&R budget with an updated rate schedule that includes the amount of insufficient revenues, if any.

## 10. Discharge Monitoring Report – Quality Assurance Study Program

The permittee shall participate in the Discharge Monitoring Report – Quality Assurance (DMR-QA) Study Program. The purpose of the DMR-QA Study Program is to annually evaluate the proficiency of all in-house and/or contract laboratory(ies) that perform, on behalf of the facility authorized to discharge under this permit, the analytical testing required under this permit. In accordance with Section 308 of the Clean Water Act (33 U.S.C. § 1318); and R 323.2138 and R 323.2154 of Part 21, Wastewater Discharge Permits, promulgated under Part 31 of the NREPA, participation in the DMR-QA Study Program is required for all major facilities, and for minor facilities selected for participation by the Department.

Annually and in accordance with DMR-QA Study Program requirements and submittal due dates, the permittee shall submit to the Michigan DMR-QA Study Program state coordinator all documentation required by the DMR-QA Study. DMR-QA Study Program participation is required only for the analytes required under this permit and only when those analytes are also identified in the DMR-QA Study.

If the permitted facility's status as a major facility should change, participation in the DMR-QA Study Program may be reevaluated. Questions concerning participation in the DMR-QA Study Program should be directed to the Michigan DMR-QA Study Program state coordinator.

All forms and instructions required for participation in the DMR-QA Study Program, including submittal due dates and state coordinator contact information, can be found at <http://www.epa.gov/compliance/discharge-monitoring-report-quality-assurance-study-program>.

## 11. Continuous Monitoring

If continuous monitoring equipment is used and becomes temporarily inoperable, the permittee shall manually obtain a minimum of three (3) equally spaced grab samples/readings within each 24-hour period for the affected parameter(s). On such days, in the comment field on the Daily tab of the DMR, the permittee shall indicate "continuous monitoring system inoperable," the date on which the system is expected to become operable again, and the number of samples/readings obtained during each 24-hour period.

**PART I****Section B. Storm Water Pollution Prevention****1. Final Effluent Limitations and Monitoring Requirements**

The permittee is authorized to discharge storm water associated with industrial activity, as defined under 40 CFR 122.26(b)(14)(i-ix), to the surface waters of the state. Such discharge shall be limited and monitored by the permittee as specified below.

- a. **Narrative Standard**  
In accordance with R 323.1050 of the Part 4 Rules promulgated pursuant to Part 31 of the NREPA, the surface waters of the state shall not, as a result of this discharge, have any of the following physical properties in unnatural quantities which are or may become injurious to any designated use: turbidity, color, oil films, floating solids, foams, settleable solids, suspended solids, or deposits.  
  
Any unusual characteristics of the discharge (i.e., unnatural turbidity, color, oil film, floating solids, foams, settleable solids, suspended solids, or deposits) shall be reported within 24 hours to the Department, followed by a written report within five (5) days detailing the findings of the investigation and the steps taken to correct the condition.
- b. **Visual Assessment of Storm Water Discharges**  
To ensure that storm water discharges from the facility do not violate the narrative standard in the receiving waters, storm water discharges shall be visually assessed in accordance with this permit.
- c. **Implementation of Storm Water Pollution Prevention Plan**  
The permittee shall implement an acceptable Storm Water Pollution Prevention Plan (SWPPP) as required by this permit.
- d. **Certified Operator**  
The permittee shall have an Industrial Storm Water Certified Operator who has supervision over the facility's storm water treatment and control measures included in the SWPPP.

*The SWPPP is a written procedure to reduce the exposure of storm water to significant materials and the amount of significant materials in the storm water discharge. An acceptable SWPPP shall identify potential sources of contamination and describe the controls necessary to reduce their impacts in accordance with Part I.B.2. through Part I.B.7. of this permit.*

## 2. Source Identification

To identify potential sources of significant materials that have reasonable potential to pollute storm water and subsequently be discharged from the facility, the SWPPP shall, at a minimum, include the following:

- a. A site map identifying:
  - 1) buildings and other permanent structures
  - 2) storage or disposal areas for significant materials
  - 3) secondary containment structures and descriptions of the significant materials contained within the primary containment structures
  - 4) storm water discharge points (which include outfalls and points of discharge), numbered or otherwise labeled for reference
  - 5) location of storm water and non-storm water inlets (numbered or otherwise labeled for reference) contributing to each storm water discharge point
  - 6) location of NPDES-permitted discharges other than storm water
  - 7) outlines of the drainage areas contributing to each storm water discharge point
  - 8) structural controls or storm water treatment facilities
  - 9) areas of vegetation (with brief descriptions such as lawn, old field, marsh, wooded, etc.)
  - 10) areas of exposed and/or erodible soils and gravel lots
  - 11) impervious surfaces (e.g., roofs, asphalt, concrete, etc.)
  - 12) name and location of receiving water(s), and
  - 13) areas of known or suspected impacts on surface waters as designated under Part 201 (Environmental Response) of the NREPA.
- b. A list of all significant materials that have reasonable potential to pollute storm water. For each material listed, the SWPPP shall include each of the following descriptions:
  - 1) identification of the storm water discharge point(s) and inlet(s) through which significant materials could discharge if released; and
  - 2) an evaluation of each material's reasonable potential to be exposed to storm water from, at a minimum, the following areas or activities listed below:

- a) loading, unloading, and other significant material-handling operations
  - b) outdoor storage, including secondary containment structures
  - c) outdoor manufacturing or processing activities
  - d) significant dust- or particulate-generating processes
  - e) discharge from vents, stacks, and air emission controls
  - f) on-site waste disposal practices
  - g) maintenance and cleaning of vehicles, machines, and equipment
  - h) areas of exposed and/or erodible soils
  - i) Sites of Environmental Contamination listed under Part 201 (Environmental Response) of the NREPA
  - j) areas of significant material residues
  - k) areas where animals (wild or domestic) congregate and deposit wastes, and
  - l) other areas where storm water may come into contact with significant materials.
- c. A listing of significant spills and significant leaks of polluting materials that occurred in areas exposed to precipitation or that discharge to a point source at the facility. The listing shall include spills that occurred over the three (3) years prior to the effective date of a permit authorizing discharge under this permit. The listing shall include the date, volume, and exact location of the release, and the action taken to clean up the material and/or prevent exposure to storm water or contamination of surface waters of the state. Any release of polluting materials that occurs after the SWPPP has been developed shall be controlled in accordance with the SWPPP and is cause for the SWPPP to be updated as appropriate within 14 calendar days of obtaining knowledge of the spill or loss.
- d. A determination as to whether the facility discharges storm water to a water body for which an EPA-approved Total Maximum Daily Load (TMDL) has been established. If so, the permittee shall assess whether the TMDL requirements for the facility's discharge are being met through the existing SWPPP controls or whether additional control measures are necessary. The permittee's assessment of whether the TMDL requirements are being met shall focus on the effectiveness, adequacy, and implementation of the permittee's SWPPP controls. The applicable TMDLs will be identified in this permit.
- e. A summary of existing storm water discharge sampling data (if available), describing pollutants in storm water discharges at the facility. This summary shall be accompanied by a description of the suspected source(s) of the pollutants detected.
- f. A description of actions taken to investigate potential illicit connections. All illicit connections to Municipal Separate Storm Sewer Systems (MS4s) or waters of the state should be permanently plugged or rerouted to the sanitary sewer system, in accordance with the authorization from the local Wastewater Treatment Plant. Any discharge from an illicit connection is a violation of the conditions of this permit.



### 3. Nonstructural Controls

To prevent significant materials from contacting storm water at the source, the SWPPP shall, at a minimum, include each of the following nonstructural controls:

- a. Written procedures and a schedule for routine preventive maintenance. Preventive maintenance procedures shall describe routine inspections and maintenance of storm water management and control devices (e.g., cleaning of oil/water separators and catch basins, routine housekeeping activities, etc.), as well as inspecting and testing plant equipment and systems to uncover conditions that could cause breakdowns or failures resulting in discharges of pollutants to the storm sewer system or the surface waters of the state. The routine inspection shall include areas of the facility in which significant materials have the reasonable potential to contaminate storm water. A written report of the inspection and corrective actions shall be retained in accordance with Record Keeping, below.
- b. Written procedures and a schedule for good housekeeping to maintain a clean, orderly facility. Good housekeeping procedures shall include routine inspections that focus on the areas of the facility that have a reasonable potential to contaminate storm water entering the property. The routine housekeeping inspections may be combined with the routine inspections for the preventive maintenance program. A written report of the inspection and corrective actions shall be retained in accordance with Record Keeping, below.
- c. Written procedures and a schedule for **quarterly** comprehensive site inspections, to be conducted by an Industrial Storm Water Certified Operator. At a minimum, one inspection shall be performed within each of the following quarters: January-March, April-June, July-September, and October-December. The comprehensive site inspections shall include, but not be limited to, inspection of structural controls in use at the facility, and the areas and equipment identified in the routine preventive maintenance and good housekeeping procedures. These inspections shall also include a review of the routine preventive maintenance reports, good housekeeping inspection reports, and any other paperwork associated with the SWPPP.

The permittee may request Department approval of an alternate schedule for comprehensive site inspections. Such a request may be made if the permittee meets the following criteria: the permittee is in full compliance with this permit, the permittee has an acceptable SWPPP, the permittee has installed and/or implemented adequate structural controls at the facility, the permittee has all required inspection reports available at the facility, and the permittee has an Industrial Storm Water Certified Operator at the facility. The Department may revoke the approval of an alternate schedule at any time upon notification to the permittee if these criteria are not being met.

A written report of the inspection and corrective actions shall be retained in accordance with Record Keeping, below, and the following shall be included on the comprehensive inspection form/report:

- 1) Date of the inspection.
- 2) Name(s), title(s), and certification number(s) of the personnel conducting the inspection.
- 3) Precipitation information (i.e., a description of recent rainfall/snowmelt events).
- 4) All observations relating to the implementation of control measures. Items to include if applicable:
  - a) updates on corrective actions implemented due to previously identified pollutant and/or discharge issues
  - b) any evidence of, or the potential for, pollutants to discharge to the drainage system or receiving waters and the condition of and around the storm water discharge point including flow dissipation measures needing maintenance or repairs
  - c) any control measures needing maintenance or repairs, and
  - d) any additional control measures needed to comply with permit requirements.
- 5) Any required revisions to the SWPPP resulting from the inspection.
- 6) A written certification stating the facility is in compliance with this permit and the SWPPP, or, if there are instances of noncompliance, they are identified.
- 7) Written procedures and a schedule for **quarterly** visual assessments of storm water discharges. At a minimum, one visual assessment shall be conducted within each of the following quarters: January-March, April-June, July-September, and October-December. These assessments shall be conducted as part of the comprehensive site inspection within one month (either prior to or after) of control measure observations made in accordance with 4), above. If the Department has approved an alternate schedule for the comprehensive site inspection, the visual assessment may likewise be conducted in accordance with the same approved alternate schedule. Additional guidance for developing written procedures for quarterly visual assessments is available on the Internet at [www.michigan.gov/eglestormwater](http://www.michigan.gov/eglestormwater), then in the center of the page, click on the 'Industrial Program' link, and find guidance documents under the 'Conducting Visual Assessments of Industrial Storm Water Discharges' heading.

The following are the requirements of the visual assessment. The permittee shall develop and clearly document, in writing, procedures for meeting these requirements:

- a) Within six (6) months of the effective date of this permit, the permittee shall develop written procedures for conducting the visual assessment and incorporate these procedures into the SWPPP. If Qualified Personnel rather than an Industrial Storm Water Certified Operator will collect storm water samples, these procedures shall include a written description of the training given to these personnel to qualify them to collect the samples, as well as documentation verifying that these personnel have received this training. The first visual assessment shall be conducted in conjunction with the next occurring comprehensive inspection. If changes resulting in altered drainage patterns occur at the facility, the permittee shall modify the procedures for conducting the visual assessment in accordance with the requirements of Keeping SWPPPs Current, below, and these modifications shall be incorporated into the SWPPP prior to conducting the next visual assessment.
- b) A visual assessment shall be conducted of a representative storm water **sample** collected **from each storm water discharge point**. Storm water samples shall be visually assessed for conditions that could cause a violation of Part I.B.1.a. of this permit. The visual assessment shall be made of the storm water sample in a clean, clear glass or plastic container. Only an Industrial Storm Water Certified Operator shall

conduct this visual assessment. Visual assessment of the storm water sample shall be conducted within 48 hours of sample collection.

Representative storm water samples shall be collected:

- (1) from each storm water discharge point identified as set forth under Source Identification, above. These samples may be collected by one or more of the following: an Industrial Storm Water Certified Operator; and/or an individual who meets qualifications acceptable to the Department and who is authorized by an Industrial Storm Water Certified Operator to collect the sample ("Qualified Personnel"); and/or an automated sampling device; and
  - (2) within the first 30 minutes of the start of a discharge from a qualifying storm event and on discharges that occur at least 72 hours (3 days) from the previous discharge. If it is not possible to collect the sample within the first 30 minutes of discharge, the sample shall be collected as soon thereafter as practicable, but not exceeding 60 minutes. In the case of snowmelt, samples shall be collected during a period with measurable discharge from the site. Sample collection may occur during the facility's normal hours of operation as described in the facility's written procedures.
- c) A visual assessment shall be conducted of the storm water **discharge at each storm water discharge point**. (If an automated sampling device is used to collect the storm water sample, this requirement is waived). Either an Industrial Storm Water Certified Operator and/or Qualified Personnel may conduct this visual assessment. This visual assessment may be conducted directly – by someone physically present at the storm water discharge at each storm water discharge point; or it may be conducted indirectly – through the use of a visual recording taken of the storm water discharge at each storm water discharge point. Direct visual assessment shall be conducted at the same time that the storm water sample is collected. Indirect visual assessment shall be conducted using a visual recording taken of the storm water discharge at the same time that the storm water sample was collected.
- d) Visual assessments shall be documented. This documentation shall be retained in accordance with Record Keeping, below, and shall include the following:
- (1) sampling location(s) at the storm water discharge point(s) identified on the site map (see Source Identification, above);
  - (2) storm event information (i.e., length of event expressed in hours, approximate size of event expressed in inches of precipitation, duration of time since previous event that caused a discharge, and date and time the discharge began);
  - (3) date and time of the visual assessment of each storm water **discharge** at each storm water discharge point;
  - (4) name(s) and title(s) of the Industrial Storm Water Certified Operator or Qualified Personnel who conducted the visual assessment of the storm water **discharge** at each storm water discharge point. If an automated sampling device was used to collect the storm water sample associated with this storm water discharge point, this documentation requirement is waived;
  - (5) observations made during visual assessment of the storm water **discharge** at each storm water discharge point. If an automated sampling device was used to collect the storm water sample associated with this storm water discharge point, this documentation requirement is waived;
  - (6) if applicable, any visual recordings used to conduct the visual assessment of the storm water **discharge** at each storm water discharge point;

- (7) date and time of sample collection for each storm water **sample**;
  - (8) name(s) and title(s) of the Industrial Storm Water Certified Operator or Qualified Personnel who collected the storm water **sample**. If an automated sampling device was used to collect the storm water sample, the permittee shall document that, instead;
  - (9) date and time of the visual assessment of each storm water **sample**;
  - (10) name(s), title(s), and operator number(s) of the Industrial Storm Water Certified Operator(s) who conducted the visual assessment of each storm water **sample**;
  - (11) observations made during visual assessment of each storm water **sample**;
  - (12) full-color photographic evidence of the storm water **sample** against a white background;
  - (13) nature of the discharge (i.e., rainfall or snowmelt);
  - (14) probable sources of any observed storm water contamination; and
  - (15) if applicable, an explanation for why it was not possible to collect samples within the first 30 minutes of discharge.
- e) When adverse weather conditions prevent a visual assessment during the quarter, a substitute visual assessment shall be conducted during the next qualifying storm event. Documentation of the rationale for no visual assessment during a quarter shall be included with the SWPPP records as described in Record Keeping, below. Adverse conditions are those that are dangerous or create inaccessibility for personnel, such as local flooding, high winds, electrical storms, or situations that otherwise make sampling impractical such as drought or extended frozen conditions.
- f) If the facility has two (2) or more storm water discharge points that are believed to discharge substantially identical storm water effluents, the facility may conduct visual assessments of the discharge at just one (1) of the storm water discharge points and report that the results also apply to the other substantially identical storm water discharge point(s). The determination of substantially identical storm water discharge points is to be based on the significant material evaluation conducted as set forth under Source Identification, above, and shall be clearly documented in the SWPPP. Visual assessments shall be conducted on a rotating basis of each substantially identical storm water discharge point throughout the period of coverage under this permit.
- d. A description of material handling procedures and storage requirements for significant materials. Equipment and procedures for cleaning up spills shall be identified in the SWPPP and made available to the appropriate personnel. The procedures shall identify measures to prevent spilled materials or material residues from contaminating storm water entering the property. The SWPPP shall include language describing what a reportable spill or release is and the appropriate reporting requirements in accordance with Part II.C.6. and Part II.C.7. of this permit. The SWPPP may include, by reference, requirements of either a Pollution Incident Prevention Plan (PIPP) prepared in accordance with the Part 5 Rules (R 324.2001 through R 324.2009 of the Michigan Administrative Code); a Hazardous Waste Contingency Plan prepared in accordance with 40 CFR 264 and 265 Subpart D, as required by Part 111 of the NREPA; or a Spill Prevention Control and Countermeasure (SPCC) plan prepared in accordance with 40 CFR 112.
- e. Identification of areas that, due to topography, activities, or other factors, have a high potential for significant soil erosion. Gravel lots shall be included. The SWPPP shall also identify measures used to control soil erosion and sedimentation. If dust suppression is used, the SWPPP shall include a description of the dust suppression material used and the actions implemented to prevent an unauthorized discharge.

- f. A description of the employee training program that will be implemented on an annual basis to inform appropriate personnel at all levels of their responsibility as it relates to the components and goals of the SWPPP. The SWPPP shall identify periodic dates for the employee training program. Records of the employee training program shall be retained in accordance with Record Keeping, below.
- g. Identification of actions to limit the discharge of significant materials in order to comply with TMDL requirements, if applicable.
- h. Identification of significant materials expected to be present in storm water discharges following implementation of nonstructural preventive measures and source controls.

#### 4. Structural Controls

Where implementation of the measures required by Nonstructural Controls, above, does not control storm water discharges in accordance with Part I.B.1.a. of this permit, the SWPPP shall provide a description of the location, function, design criteria, and installation/construction schedule of structural controls for prevention and treatment. Structural controls may be necessary:

- a. to prevent uncontaminated storm water from contacting, or being contacted by, significant materials; or
- b. if preventive measures are not feasible or are inadequate to keep significant materials at the site from contaminating storm water. Structural controls shall be used to treat, divert, isolate, recycle, reuse, or otherwise manage storm water in a manner that reduces the level of significant materials in the storm water and provides compliance with Part I.B.1.a. of this permit.

#### 5. Keeping SWPPPs Current

- a. The permittee and/or an Industrial Storm Water Certified Operator shall review the SWPPP annually after it is developed and maintain a written report of the review in accordance with Record Keeping, below. Based on the review, the permittee or an Industrial Storm Water Certified Operator shall amend the SWPPP as needed to ensure continued compliance with the terms and conditions of this permit. The written report shall be submitted to the Department on or before January 10 of each year.
- b. The SWPPP developed under the conditions of a previous permit shall be amended as necessary to ensure compliance with this permit.
- c. The SWPPP shall be updated or amended whenever changes at the facility have the potential to increase the exposure of significant materials to storm water, significant spills occur at the facility, or when the SWPPP is determined by the permittee or the Department to be ineffective in achieving the general objectives of controlling pollutants in storm water discharges associated with industrial activity. SWPPP updates necessitated by increased activity or significant spills at the facility shall include a description of how the permittee intends to control any new sources of significant materials, or respond to and prevent spills in accordance with the requirements of this permit (see Source Identification; Nonstructural Controls; and Structural Controls, above).
- d. The Department may notify the permittee at any time that the SWPPP does not meet minimum requirements of this permit. Such notification shall identify why the SWPPP does not meet minimum requirements of this permit. The permittee shall make the required changes to the SWPPP within 30 days after such notification from the Department and shall submit to the Department a written certification that the requested changes have been made.
- e. Amendments to the SWPPP shall be signed and retained on-site with the SWPPP pursuant to Signature and SWPPP Review, below.

## 6. Contact Information and Industrial Storm Water Certified Operator Update

- a. The SWPPP shall include contact information (i.e. mailing address, phone number, and email address) for the Facility Contact, Industrial Storm Water Certified Operator, environmental consultant, and/or any other appropriate individuals who manage the storm water program at the facility.
- b. If an Industrial Storm Water Certified Operator is changed or an Industrial Storm Water Certified Operator is added, the permittee shall provide the name and certification number of the new Industrial Storm Water Certified Operator to the Department. If a facility has multiple Industrial Storm Water Certified Operators, the names and certification numbers of all shall be included in the SWPPP.

## 7. Signature and SWPPP Review

- a. The SWPPP shall be reviewed and signed by an Industrial Storm Water Certified Operator(s) and by either the permittee or an authorized representative in accordance with 40 CFR 122.22. The SWPPP and associated records shall be retained on-site at the facility that generates the storm water discharge.
- b. The permittee shall make the SWPPP, reports, log books, storm water discharge sampling data (if collected), visual assessment documentation, and items required by Record Keeping, below, available upon request to the Department. The Department makes the non-confidential business portions of the SWPPP available to the public.

## 8. Record Keeping

The permittee shall maintain records of all SWPPP-related inspection and maintenance activities. All such records shall be retained for three (3) years. The following records are required by this permit (see Nonstructural Controls; and Keeping SWPPPs Current, above):

- a. routine preventive maintenance inspection reports
- b. routine good housekeeping inspection reports
- c. comprehensive site inspection reports
- d. documentation of visual assessments
- e. employee training records, and
- f. annual SWPPP review reports.

## 9. Non-Storm Water Discharges

Storm water is defined in Part II.A. of this permit to encompass non-storm water discharges included under the conditions of this permit. Any discharge of wastewater other than storm water as defined under the conditions of this permit shall be in compliance with an NPDES permit issued for the discharge. The non-storm water discharges included under the conditions of this permit are authorized under this permit, provided pollution prevention controls for the non-storm water component are identified in the permittee's SWPPP. The non-storm water discharges included under the conditions of this permit are as follows:

- a. discharges from fire hydrant flushing
- b. potable water sources, including water line flushing
- c. water from fire system testing and fire-fighting training without burned materials or chemical fire suppressants
- d. irrigation drainage
- e. lawn watering
- f. routine building wash-down that does not use detergents or other compounds
- g. pavement wash waters where contamination by toxic or hazardous materials has not occurred (unless all contamination by toxic or hazardous materials has been removed) and where detergents are not used
- h. uncontaminated condensate from air conditioners, coolers, and other compressors and from the outside storage of refrigerated gases or liquids
- i. springs
- j. uncontaminated groundwater
- k. foundation or footing drains where flows are not contaminated with process materials such as solvents, and
- l. discharges from fire-fighting activities. Discharges from fire-fighting activities are exempted from the requirement to be identified in the SWPPP.

## 10. Tracer Dye Discharges

This permit does not authorize the discharge of tracer dyes without approval from the Department. Requests to discharge tracer dyes shall be submitted to the Department in accordance with Rule 1097 (R 323.1097 of the Michigan Administrative Code).

**PART I****Section C. Industrial Waste Pretreatment Program****1. Michigan Industrial Pretreatment Program**

- a. The permittee shall implement the Michigan Industrial Pretreatment Program (MIPP) approved on July 18, 1990, and any subsequent modifications approved up to the issuance of this permit.
- b. The permittee shall comply with R 323.2301 through R 323.2317 of the Michigan Administrative Code (Part 23 Rules) and the approved MIPP.
- c. The permittee shall have the legal authority and necessary interjurisdictional agreements that provide the basis for the implementation and enforcement of the approved MIPP throughout the service area. The legal authority and necessary interjurisdictional agreements shall include, at a minimum, the authority to carry out the activities specified in R 323.2306(a).
- d. The permittee shall develop procedures which describe, in sufficient detail, program commitments which enable implementation of the approved MIPP and the Part 23 Rules in accordance with R 323.2306(c).
- e. The permittee shall establish an interjurisdictional agreement (or comparable document) with all tributary governmental jurisdictions. Each interjurisdictional agreement shall contain, at a minimum, the following:
  - 1) identification of the agency responsible for the implementation and enforcement of the approved MIPP within the tributary governmental jurisdiction's boundaries; and
  - 2) the provision of the legal authority which provides the basis for the implementation and enforcement of the approved MIPP within the tributary governmental jurisdiction's boundaries.
- f. The permittee shall prohibit discharges that:
  - 1) cause, in whole or in part, the permittee's failure to comply with any condition of this permit or the NREPA;
  - 2) restrict, in whole or in part, the permittee's management of biosolids;
  - 3) cause, in whole or in part, operational problems at the treatment facility or in its collection system;
  - 4) violate any of the general or specific prohibitions identified in R 323.2303(1) and (2);
  - 5) violate categorical standards identified in R 323.2311; and
  - 6) violate local limits established in accordance with R 323.2303(4).
- g. The permittee shall maintain a list of its nondomestic users that meet the criteria of a significant industrial user as identified in R 323.2302(cc).
- h. The permittee shall develop an enforcement response plan which describes, in sufficient detail, program commitments which will enable the enforcement of the approved MIPP and the Part 23 Rules in accordance with R 323.2306(g).
- i. The Department may require modifications to the approved MIPP which are necessary to ensure compliance with the Part 23 Rules in accordance with R 323.2309.



- j. The permittee shall not implement changes or modifications to the approved MIPP without notification to the Department.
- k. The permittee shall maintain an adequate revenue structure and staffing level for effective implementation of the approved MIPP.
- l. The permittee shall develop and maintain, for a minimum of three (3) years, all records and information necessary to determine nondomestic user compliance with the Part 23 Rules and the approved MIPP. This period of retention shall be extended during the course of any unresolved enforcement action or litigation regarding a nondomestic user or when requested by the Department or the United States Environmental Protection Agency. All of the aforementioned records and information shall be made available upon request for inspection and copying by the Department and the United States Environmental Protection Agency.
- m. The permittee shall evaluate the approved MIPP for compliance with the Part 23 Rules and the prohibitions set forth in item f. above. Based upon this evaluation, the permittee shall propose to the Department all necessary changes or modifications to the approved MIPP no later than the next Industrial Pretreatment Program Annual Report due date (see item p. below).
- n. The permittee shall develop and enforce local limits to implement the prohibitions set forth in item f. above. Local limits shall be based upon data representative of actual conditions demonstrated in a maximum allowable headworks loading analysis.
- o. The permittee is required under this permit and R 323.2303(4) of the Michigan Administrative Code to review and update their local limits when:
- 1) new pollutants are introduced;
  - 2) new pollutants that were previously unevaluated are identified;
  - 3) new water quality or biosolids standards are established or additional information becomes available about the nature of pollutants, such as removal rates and accumulation in biosolids; or
  - 4) substantial increases of pollutants are proposed as required in the notification of new or increased uses in accordance with the provisions of 40 CFR 122.42.
- p. On or before April 1 of each year, the permittee shall submit to the Department, as required by R 323.2310(8), an Industrial Pretreatment Program Annual Report on the status of program implementation and enforcement activities. The reporting period shall begin on January 1 and end on December 31. At a minimum, the Industrial Pretreatment Program Annual Report shall include:
- 1) the Pretreatment Program Reports data identified in Appendix A to 40 CFR Part 127 – NPDES Electronic Reporting;
  - 2) a summary of changes to the approved MIPP that have not been previously reported to the Department;
  - 3) a summary of results of all the sampling and analyses performed of the wastewater treatment plant's influent, effluent, and biosolids conducted in accordance with approved methods during the reporting period. The summary shall include the monthly average, daily maximum, quantification level, and number of samples analyzed for each pollutant. At a minimum, the results of analyses for all locally limited parameters for at least one monitoring event that tests influent, effluent and biosolids during the reporting period shall be submitted with each report, unless otherwise required by the Department. Sample collection shall be at intervals sufficient to provide pollutant removal rates, unless the pollutant is not measurable; and
  - 4) any other relevant information requested by the Department.

**PART I****Section D. Residuals Management Program****1. Residuals Management Program for Land Application of Biosolids**

The permittee is authorized to land-apply bulk biosolids or prepare bulk biosolids for land application in accordance with the permittee's approved Residuals Management Program (RMP) approved on May 23, 2002, and approved modifications thereto, and the requirements established in R 323.2401 through R 323.2418 of the Michigan Administrative Code (Part 24 Rules). The approved RMP, and any approved modifications thereto, are enforceable requirements of this permit. Incineration, landfilling and other residual disposal activities shall be conducted in accordance with Part II.D.7. of this permit. The Part 24 Rules can be obtained via the internet (<http://www.michigan.gov/egle/> and near the top of the screen click on Water, then towards the bottom right of the screen click on Permits, Wastewater, Biosolids, then click on Biosolids Laws and Rules Information which is under the Laws & Rules banner in the center of the screen).

**a. Annual Report**

On or before October 30 of each year, the permittee shall submit an annual report to the Department for the previous fiscal year of October 1 through September 30. The report shall be submitted electronically via the Department's MiWaters system at <https://miwaters.deq.state.mi.us>. At a minimum, the report shall contain:

1) a certification that current residuals management practices are in accordance with the approved RMP, or a proposal for modification to the approved RMP; and

2) a completed Annual Report Form for Reporting Biosolids, available at <https://miwaters.deq.state.mi.us>.

**b. Modifications to the Approved RMP**

Prior to implementation of modifications to the RMP, the permittee shall submit proposed modifications to the Department for approval. The approved modification shall become effective upon the date of approval. Upon written notification, the Department may impose additional requirements and/or limitations to the approved RMP as necessary to protect public health and the environment from any adverse effect of a pollutant in the biosolids.

**c. Record Keeping**

Records required by the Part 24 Rules shall be kept for a minimum of five (5) years. However, the records documenting cumulative loading for sites subject to cumulative pollutant loading rates shall be kept as long as the site receives biosolids.

**d. Contact Information**

RMP-related submittals shall be made to the Department.

## PART II

Part II may include terms and /or conditions not applicable to discharges covered under this permit.

### Section A. Definitions

**Acute toxic unit (TU<sub>A</sub>)** means  $100/LC_{50}$  where the  $LC_{50}$  is determined from a whole effluent toxicity (WET) test which produces a result that is statistically or graphically estimated to be lethal to 50% of the test organisms.

**Annual monitoring frequency** refers to a calendar year beginning on January 1 and ending on December 31. When required by this permit, an analytical result, reading, value or observation shall be reported for that period if a discharge occurs during that period.

**Authorized public agency** means a state, local, or county agency that is designated pursuant to the provisions of Section 9110 of Part 91, Soil and Sedimentation Control, of the NREPA, to implement soil erosion and sedimentation control requirements with regard to construction activities undertaken by that agency.

**Best management practices (BMPs)** means structural devices or nonstructural practices that are designed to prevent pollutants from entering into storm water, to direct the flow of storm water, or to treat polluted storm water.

**Bioaccumulative chemical of concern (BCC)** means a chemical which, upon entering the surface waters, by itself or as its toxic transformation product, accumulates in aquatic organisms by a human health bioaccumulation factor of more than 1000 after considering metabolism and other physiochemical properties that might enhance or inhibit bioaccumulation. The human health bioaccumulation factor shall be derived according to R 323.1057(5). Chemicals with half-lives of less than 8 weeks in the water column, sediment, and biota are not BCCs. The minimum bioaccumulation concentration factor (BAF) information needed to define an organic chemical as a BCC is either a field-measured BAF or a BAF derived using the biota-sediment accumulation factor (BSAF) methodology. The minimum BAF information needed to define an inorganic chemical as a BCC, including an organometal, is either a field-measured BAF or a laboratory-measured bioconcentration factor (BCF). The BCCs to which these rules apply are identified in Table 5 of R 323.1057 of the Water Quality Standards.

**Biosolids** are the solid, semisolid, or liquid residues generated during the treatment of sanitary sewage or domestic sewage in a treatment works. This includes, but is not limited to, scum or solids removed in primary, secondary, or advanced wastewater treatment processes and a derivative of the removed scum or solids.

**Bulk biosolids** means biosolids that are not sold or given away in a bag or other container for application to a lawn or home garden.

**Certificate of Coverage (COC)** is a document, issued by the Department, which authorizes a discharge under a general permit.

**Chronic toxic unit (TU<sub>C</sub>)** means  $100/MATC$  or  $100/IC_{25}$ , where the maximum acceptable toxicant concentration (MATC) and  $IC_{25}$  are expressed as a percent effluent in the test medium.

**Class B biosolids** refers to material that has met the Class B pathogen reduction requirements or equivalent treatment by a Process to Significantly Reduce Pathogens (PSRP) in accordance with the Part 24 Rules, Land Application of Biosolids, promulgated under Part 31 of the NREPA. Processes include aerobic digestion, composting, anaerobic digestion, lime stabilization and air drying.

**Combined sewer system** is a sewer system in which storm water runoff is combined with sanitary wastes.

**Daily concentration**

FOR PARAMETERS OTHER THAN pH, DISSOLVED OXYGEN, TEMPERATURE, AND CONDUCTIVITY – Daily concentration is the sum of the concentrations of the individual samples of a parameter taken within a calendar day divided by the number of samples taken within that calendar day. The daily concentration will be used to determine compliance with any maximum and minimum daily concentration limitations. For guidance and examples showing how to perform calculations using results below quantification levels, see the document entitled “Reporting Results Below Quantification,” available at [https://www.michigan.gov/documents/deq/wrd-ncdes-results-quantification\\_620791\\_7.pdf](https://www.michigan.gov/documents/deq/wrd-ncdes-results-quantification_620791_7.pdf).

FOR pH, DISSOLVED OXYGEN, TEMPERATURE, AND CONDUCTIVITY – The daily concentration used to determine compliance with maximum daily pH, temperature, and conductivity limitations is the highest pH, temperature, and conductivity readings obtained within a calendar day. The daily concentration used to determine compliance with minimum daily pH and dissolved oxygen limitations is the lowest pH and dissolved oxygen readings obtained within a calendar day.

**Daily loading** is the total discharge by weight of a parameter discharged during any calendar day. This value is calculated by multiplying the daily concentration by the total daily flow and by the appropriate conversion factor. The daily loading will be used to determine compliance with any maximum daily loading limitations. When required by the permit, report the maximum calculated daily loading for the month in the “MAXIMUM” column under “QUANTITY OR LOADING” on the DMRs.

**Daily monitoring frequency** refers to a 24-hour day. When required by this permit, an analytical result, reading, value or observation shall be reported for that period if a discharge occurs during that period.

**Department** means the Michigan Department of Environment, Great Lakes, and Energy.

**Detection level** means the lowest concentration or amount of the target analyte that can be determined to be different from zero by a single measurement at a stated level of probability.

**Discharge** means the addition of any waste, waste effluent, wastewater, pollutant, or any combination thereof to any surface water of the state.

**EC<sub>50</sub>** means a statistically or graphically estimated concentration that is expected to cause 1 or more specified effects in 50% of a group of organisms under specified conditions.

**Fecal coliform bacteria monthly**

FOR WWSLs THAT COLLECT AND STORE WASTEWATER AND ARE AUTHORIZED TO DISCHARGE ONLY IN THE SPRING AND/OR FALL ON AN INTERMITTENT BASIS – Fecal coliform bacteria monthly is the geometric mean of all daily concentrations determined during a discharge event. Days on which no daily concentration is determined shall not be used to determine the calculated monthly value. The calculated monthly value will be used to determine compliance with the maximum monthly fecal coliform bacteria limitations. When required by the permit, report the calculated monthly value in the “AVERAGE” column under “QUALITY OR CONCENTRATION” on the DMR. If the period in which the discharge event occurred was partially in each of two months, the calculated monthly value shall be reported on the DMR of the month in which the last day of discharge occurred.

FOR ALL OTHER DISCHARGES – Fecal coliform bacteria monthly is the geometric mean of all daily concentrations determined during a reporting month. Days on which no daily concentration is determined shall not be used to determine the calculated monthly value. The calculated monthly value will be used to determine compliance with the maximum monthly fecal coliform bacteria limitations. When required by the permit, report the calculated monthly value in the “AVERAGE” column under “QUALITY OR CONCENTRATION” on the DMR.

**Fecal coliform bacteria 7-day**

FOR WWSLs THAT COLLECT AND STORE WASTEWATER AND ARE AUTHORIZED TO DISCHARGE ONLY IN THE SPRING AND/OR FALL ON AN INTERMITTENT BASIS – Fecal coliform bacteria 7-day is the geometric mean of the daily concentrations determined during any 7 consecutive days of discharge during a discharge event. If the number of daily concentrations determined during the discharge event is less than 7 days, the number of actual daily concentrations determined shall be used for the calculation. Days on which no daily concentration is determined shall not be used to determine the value. The calculated 7-day value will be used to determine compliance with the maximum 7-day fecal coliform bacteria limitations. When required by the permit, report the maximum calculated 7-day geometric mean value for the month in the “MAXIMUM” column under “QUALITY OR CONCENTRATION” on the DMRs. If the 7-day period was partially in each of two months, the value shall be reported on the DMR of the month in which the last day of discharge occurred.

FOR ALL OTHER DISCHARGES – Fecal coliform bacteria 7-day is the geometric mean of the daily concentrations determined during any 7 consecutive days in a reporting month. If the number of daily concentrations determined is less than 7, the actual number of daily concentrations determined shall be used for the calculation. Days on which no daily concentration is determined shall not be used to determine the value. The calculated 7-day value will be used to determine compliance with the maximum 7-day fecal coliform bacteria limitations. When required by the permit, report the maximum calculated 7-day geometric mean for the month in the “MAXIMUM” column under “QUALITY OR CONCENTRATION” on the DMRs. The first calculation shall be made on day 7 of the reporting month, and the last calculation shall be made on the last day of the reporting month.

**Flow-proportioned sample** is a composite sample with the sample volume proportional to the effluent flow.

**General permit** means an NPDES permit issued authorizing a category of similar discharges.

**Geometric mean** is the average of the logarithmic values of a base 10 data set, converted back to a base 10 number.

**Grab sample** is a single sample taken at neither a set time nor flow.

**IC<sub>25</sub>** means the toxicant concentration that would cause a 25% reduction in a nonquantal biological measurement for the test population.

**Illicit connection** means a physical connection to a municipal separate storm sewer system that primarily conveys non-storm water discharges other than uncontaminated groundwater into the storm sewer; or a physical connection not authorized or permitted by the local authority, where a local authority requires authorization or a permit for physical connections.

**Illicit discharge** means any discharge to, or seepage into, a municipal separate storm sewer system that is not composed entirely of storm water or uncontaminated groundwater. Illicit discharges include non-storm water discharges through pipes or other physical connections; dumping of motor vehicle fluids, household hazardous wastes, domestic animal wastes, or litter; collection and intentional dumping of grass clippings or leaf litter; or unauthorized discharges of sewage, industrial waste, restaurant wastes, or any other non-storm water waste directly into a separate storm sewer.

**Individual permit** means a site-specific NPDES permit.

**Inlet** means a catch basin, roof drain, conduit, drain tile, retention pond riser pipe, sump pump, or other point where storm water or wastewater enters into a closed conveyance system prior to discharge off site or into waters of the state.

**Interference** is a discharge which, alone or in conjunction with a discharge or discharges from other sources, both: 1) inhibits or disrupts a POTW, its treatment processes or operations, or its sludge processes, use or disposal; and 2) therefore, is a cause of a violation of any requirement of the POTW's NPDES permit (including an increase in the magnitude or duration of a violation) or, of the prevention of sewage sludge use or disposal in compliance with the following statutory provisions and regulations or permits issued thereunder (or more stringent state or local regulations): Section 405 of the Clean Water Act, the Solid Waste Disposal Act (SWDA) (including Title II, more commonly referred to as the Resource Conservation and Recovery Act (RCRA), and including state regulations contained in any state sludge management plan prepared pursuant to Subtitle D of the SWDA), the Clean Air Act, the Toxic Substances Control Act, and the Marine Protection, Research and Sanctuaries Act. [This definition does not apply to sample matrix interference].

**Land application** means spraying or spreading biosolids or a biosolids derivative onto the land surface, injecting below the land surface, or incorporating into the soil so that the biosolids or biosolids derivative can either condition the soil or fertilize crops or vegetation grown in the soil.

**LC<sub>50</sub>** means a statistically or graphically estimated concentration that is expected to be lethal to 50% of a group of organisms under specified conditions.

**Maximum acceptable toxicant concentration (MATC)** means the concentration obtained by calculating the geometric mean of the lower and upper chronic limits from a chronic test. A lower chronic limit is the highest tested concentration that did not cause the occurrence of a specific adverse effect. An upper chronic limit is the lowest tested concentration which did cause the occurrence of a specific adverse effect and above which all tested concentrations caused such an occurrence.

**Maximum extent practicable** means implementation of best management practices by a public body to comply with an approved storm water management program as required by a national permit for a municipal separate storm sewer system, in a manner that is environmentally beneficial, technically feasible, and within the public body's legal authority.

**MBTU/hr** means million British Thermal Units per hour.

**MGD** means million gallons per day.

**Monthly concentration** is the sum of the daily concentrations determined during a reporting period divided by the number of daily concentrations determined. The calculated monthly concentration will be used to determine compliance with any maximum monthly concentration limitations. Days with no discharge shall not be used to determine the value. When required by the permit, report the calculated monthly concentration in the "AVERAGE" column under "QUALITY OR CONCENTRATION" on the DMR.

For minimum percent removal requirements, the monthly influent concentration and the monthly effluent concentration shall be determined. The calculated monthly percent removal, which is equal to 100 times the quantity [1 minus the quantity (monthly effluent concentration divided by the monthly influent concentration)], shall be reported in the "MINIMUM" column under "QUALITY OR CONCENTRATION" on the DMRs.

**Monthly loading** is the sum of the daily loadings of a parameter divided by the number of daily loadings determined during a reporting period. The calculated monthly loading will be used to determine compliance with any maximum monthly loading limitations. Days with no discharge shall not be used to determine the value. When required by the permit, report the calculated monthly loading in the "AVERAGE" column under "QUANTITY OR LOADING" on the DMR.

**Monthly monitoring frequency** refers to a calendar month. When required by this permit, an analytical result, reading, value or observation shall be reported for that period if a discharge occurs during that period.

**Municipal separate storm sewer** means a conveyance or system of conveyances designed or used for collecting or conveying storm water which is not a combined sewer and which is not part of a POTW as defined in the Code of Federal Regulations at 40 CFR 122.2.

**Municipal separate storm sewer system (MS4)** means all separate storm sewers that are owned or operated by the United States, a state, city, village, township, county, district, association, or other public body created by or pursuant to state law, having jurisdiction over disposal of sewage, industrial wastes, storm water, or other wastes, including special districts under state law, such as a sewer district, flood control district, or drainage district, or similar entity, or a designated or approved management agency under Section 208 of the Clean Water Act that discharges to the waters of the state. This term includes systems similar to separate storm sewer systems in municipalities, such as systems at military bases, large hospital or prison complexes, and highways and other thoroughfares. The term does not include separate storm sewers in very discrete areas, such as individual buildings.

**National Pretreatment Standards** are the regulations promulgated by or to be promulgated by the Federal Environmental Protection Agency pursuant to Section 307(b) and (c) of the Clean Water Act. The standards establish nationwide limits for specific industrial categories for discharge to a POTW.

**No observed adverse effect level (NOAEL)** means the highest tested dose or concentration of a substance which results in no observed adverse effect in exposed test organisms where higher doses or concentrations result in an adverse effect.

**Noncontact cooling water** is water used for cooling which does not come into direct contact with any raw material, intermediate product, by-product, waste product or finished product.

**Nondomestic user** is any discharger to a POTW that discharges wastes other than or in addition to water-carried wastes from toilet, kitchen, laundry, bathing or other facilities used for household purposes.

**Nonstructural controls** are practices or procedures implemented by employees at a facility to manage storm water or to prevent contamination of storm water.

**NPDES** means National Pollutant Discharge Elimination System.

**Outfall** is the location at which a point source discharge first enters a surface water of the state.

**Part 91 agency** means an agency that is designated by a county board of commissioners pursuant to the provisions of Section 9105 of Part 91 of the NREPA; an agency that is designated by a city, village, or township in accordance with the provisions of Section 9106 of Part 91 of the NREPA; or the Department for soil erosion and sedimentation control activities under Part 615, Supervisor of Wells; Part 631, Reclamation of Mining Lands; or Part 632, Nonferrous Metallic Mineral Mining, of the NREPA, pursuant to the provisions of Section 9115 of Part 91 of the NREPA.

**Part 91 permit** means a soil erosion and sedimentation control permit issued by a Part 91 agency pursuant to the provisions of Part 91 of the NREPA.

**Partially treated sewage** is any sewage, sewage and storm water, or sewage and wastewater, from domestic or industrial sources that is treated to a level less than that required by the permittee's NPDES permit, or that is not treated to national secondary treatment standards for wastewater, including discharges to surface waters from retention treatment facilities.

**Point of discharge** is the location of a point source discharge where storm water is discharged directly into a separate storm sewer system.

**Point source discharge** means a discharge from any discernible, confined, discrete conveyance, including but not limited to any pipe, ditch, channel, tunnel, conduit, well, discrete fissure, container, or rolling stock. Changing the surface of land or establishing grading patterns on land will result in a point source discharge where the runoff from the site is ultimately discharged to waters of the state.

**Polluting material** means any material, in solid or liquid form, identified as a polluting material under the Part 5 Rules, Spillage of Oil and Polluting Materials, promulgated under Part 31 of the NREPA (R 324.2001 through R 324.2009 of the Michigan Administrative Code).

**POTW** is a publicly owned treatment work.

**Predevelopment** is the last land use prior to the planned new development or redevelopment.

**Pretreatment** is reducing the amount of pollutants, eliminating pollutants, or altering the nature of pollutant properties to a less harmful state prior to discharge into a public sewer. The reduction or alteration can be by physical, chemical, or biological processes, process changes, or by other means. Dilution is not considered pretreatment unless expressly authorized by an applicable National Pretreatment Standard for a particular industrial category.

**Public** (as used in the MS4 individual permit) means all persons who potentially could affect the authorized storm water discharges, including, but not limited to, residents, visitors to the area, public employees, businesses, industries, and construction contractors and developers.

**Public body** means the United States; the state of Michigan; a city, village, township, county, school district, public college or university, or single-purpose governmental agency; or any other body which is created by federal or state statute or law.

**Qualified Personnel** means an individual who meets qualifications acceptable to the Department and who is authorized by an Industrial Storm Water Certified Operator to collect the storm water sample.

**Qualifying storm event** means a storm event causing greater than 0.1 inch of rainfall and occurring at least 72 hours after the previous measurable storm event that also caused greater than 0.1 inch of rainfall. Upon request, the Department may approve an alternate definition meeting the condition of a qualifying storm event.

**Quantification level** means the measurement of the concentration of a contaminant obtained by using a specified laboratory procedure calculated at a specified concentration above the detection level. It is considered the lowest concentration at which a particular contaminant can be quantitatively measured using a specified laboratory procedure for monitoring of the contaminant.

**Quarterly monitoring frequency** refers to a three month period, defined as January through March, April through June, July through September, and October through December. When required by this permit, an analytical result, reading, value or observation shall be reported for that period if a discharge occurs during that period.

**Regional Administrator** is the Region 5 Administrator, U.S. EPA, located at R-19J, 77 W. Jackson Blvd., Chicago, Illinois 60604.

**Regulated area** means the permittee's urbanized area, where urbanized area is defined as a place and its adjacent densely-populated territory that together have a minimum population of 50,000 people as defined by the United States Bureau of the Census and as determined by the latest available decennial census.

**Secondary containment structure** means a unit, other than the primary container, in which significant materials are packaged or held, which is required by state or federal law to prevent the escape of significant materials by gravity into sewers, drains, or otherwise directly or indirectly into any sewer system or to the surface waters or groundwaters of the state.

**Separate storm sewer system** means a system of drainage, including, but not limited to, roads, catch basins, curbs, gutters, parking lots, ditches, conduits, pumping devices, or man-made channels, which is not a combined sewer where storm water mixes with sanitary wastes, and is not part of a POTW.

**Significant industrial user** is a nondomestic user that: 1) is subject to Categorical Pretreatment Standards under 40 CFR 403.6 and 40 CFR Chapter I, Subchapter N; or 2) discharges an average of 25,000 gallons per day or more of process wastewater to a POTW (excluding sanitary, noncontact cooling and boiler blowdown wastewater); contributes a process waste stream which makes up five (5) percent or more of the average dry weather hydraulic or organic capacity of the POTW treatment plant; or is designated as such by the permittee as defined in 40 CFR 403.12(a) on the basis that the industrial user has a reasonable potential for adversely affecting the POTW's treatment plant operation or violating any pretreatment standard or requirement (in accordance with 40 CFR 403.8(f)(6)).



**Significant materials** means any material which could degrade or impair water quality, including but not limited to: raw materials; fuels; solvents, detergents, and plastic pellets; finished materials such as metallic products; hazardous substances designated under Section 101(14) of the Comprehensive Environmental Response, Compensation, and Liability Act (CERCLA) (see 40 CFR 372.65); any chemical the facility is required to report pursuant to Section 313 of Emergency Planning and Community Right-to-Know Act (EPCRA); polluting materials as identified under the Part 5 Rules (R 324.2001 through R 324.2009 of the Michigan Administrative Code); Hazardous Wastes as defined in Part 111, Hazardous Waste Management, of the NREPA; fertilizers; pesticides; and waste products such as ashes, slag, and sludge that have the potential to be released with storm water discharges.

**Significant spills and significant leaks** means any release of a polluting material reportable under the Part 5 Rules (R 324.2001 through R 324.2009 of the Michigan Administrative Code).

**Special-use area** means storm water discharges for which the Department has determined that additional monitoring is needed from: secondary containment structures required by state or federal law; lands on Michigan's List of Sites of Environmental Contamination pursuant to Part 201, Environmental Remediation, of the NREPA; and/or areas with other activities that may contribute pollutants to the storm water.

**Stoichiometric** means the quantity of a reagent calculated to be necessary and sufficient for a given chemical reaction.

**Storm water** means storm water runoff, snow melt runoff, surface runoff and drainage, and non-storm water included under the conditions of this permit.

**Storm water discharge point** is the location where the point source discharge of storm water is directed to surface waters of the state or to a separate storm sewer. It includes the location of all point source discharges where storm water exits the facility, including *outfalls* which discharge directly to surface waters of the state, and *points of discharge* which discharge directly into separate storm sewer systems.

**Structural controls** are physical features or structures used at a facility to manage or treat storm water.

**SWPPP** means the Storm Water Pollution Prevention Plan prepared in accordance with this permit.

**Tier I value** means a value for aquatic life, human health or wildlife calculated under R 323.1057 of the Water Quality Standards using a tier I toxicity database.

**Tier II value** means a value for aquatic life, human health or wildlife calculated under R 323.1057 of the Water Quality Standards using a tier II toxicity database.

**Total maximum daily loads (TMDLs)** are required by the Clean Water Act for waterbodies that do not meet water quality standards. TMDLs represent the maximum daily load of a pollutant that a waterbody can assimilate and meet water quality standards, and an allocation of that load among point sources, nonpoint sources, and a margin of safety.

**Toxicity reduction evaluation (TRE)** means a site-specific study conducted in a stepwise process designed to identify the causative agents of effluent toxicity, isolate the sources of toxicity, evaluate the effectiveness of toxicity control options, and then confirm the reduction in effluent toxicity.

**Water Quality Standards** means the Part 4 Water Quality Standards promulgated pursuant to Part 31 of the NREPA, being R 323.1041 through R 323.1117 of the Michigan Administrative Code.

**Weekly monitoring frequency** refers to a calendar week which begins on Sunday and ends on Saturday. When required by this permit, an analytical result, reading, value or observation shall be reported for that period if a discharge occurs during that period.

**WWSL** is a wastewater stabilization lagoon.

**WWSL discharge event** is a discrete occurrence during which effluent is discharged to the surface water up to 10 days of a consecutive 14 day period.

**3-portion composite sample** is a sample consisting of three equal-volume grab samples collected at equal intervals over an 8-hour period.

#### **7-day concentration**

FOR WWSLs THAT COLLECT AND STORE WASTEWATER AND ARE AUTHORIZED TO DISCHARGE ONLY IN THE SPRING AND/OR FALL ON AN INTERMITTENT BASIS – The 7-day concentration is the sum of the daily concentrations determined during any 7 consecutive days of discharge during a WWSL discharge event divided by the number of daily concentrations determined. If the number of daily concentrations determined during the WWSL discharge event is less than 7 days, the number of actual daily concentrations determined shall be used for the calculation. The calculated 7-day concentration will be used to determine compliance with any maximum 7-day concentration limitations. When required by the permit, report the maximum calculated 7-day concentration for the WWSL discharge event in the “MAXIMUM” column under “QUALITY OR CONCENTRATION” on the DMR. If the WWSL discharge event was partially in each of two months, the value shall be reported on the DMR of the month in which the last day of discharge occurred.

FOR ALL OTHER DISCHARGES – The 7-day concentration is the sum of the daily concentrations determined during any 7 consecutive days in a reporting month divided by the number of daily concentrations determined. If the number of daily concentrations determined is less than 7, the actual number of daily concentrations determined shall be used for the calculation. The calculated 7-day concentration will be used to determine compliance with any maximum 7-day concentration limitations in the reporting month. When required by the permit, report the maximum calculated 7-day concentration for the month in the “MAXIMUM” column under “QUALITY OR CONCENTRATION” on the DMR. The first 7-day calculation shall be made on day 7 of the reporting month, and the last calculation shall be made on the last day of the reporting month.

#### **7-day loading**

FOR WWSLs THAT COLLECT AND STORE WASTEWATER AND ARE AUTHORIZED TO DISCHARGE ONLY IN THE SPRING AND/OR FALL ON AN INTERMITTENT BASIS – The 7-day loading is the sum of the daily loadings determined during any 7 consecutive days of discharge during a WWSL discharge event divided by the number of daily loadings determined. If the number of daily loadings determined during the WWSL discharge event is less than 7 days, the number of actual daily loadings determined shall be used for the calculation. The calculated 7-day loading will be used to determine compliance with any maximum 7-day loading limitations. When required by the permit, report the maximum calculated 7-day loading for the WWSL discharge event in the “MAXIMUM” column under “QUANTITY OR LOADING” on the DMR. If the WWSL discharge event was partially in each of two months, the value shall be reported on the DMR of the month in which the last day of discharge occurred.

FOR ALL OTHER DISCHARGES – The 7-day loading is the sum of the daily loadings determined during any 7 consecutive days in a reporting month divided by the number of daily loadings determined. If the number of daily loadings determined is less than 7, the actual number of daily loadings determined shall be used for the calculation. The calculated 7-day loading will be used to determine compliance with any maximum 7-day loading limitations in the reporting month. When required by the permit, report the maximum calculated 7-day loading for the month in the “MAXIMUM” column under “QUANTITY OR LOADING” on the DMR. The first 7-day calculation shall be made on day 7 of the reporting month, and the last calculation shall be made on the last day of the reporting month.

**24-hour composite sample** is a flow-proportioned composite sample consisting of hourly or more frequent portions that are taken over a 24-hour period. A time-proportioned composite sample may be used upon approval of the Department if the permittee demonstrates it is representative of the discharge.

## PART II

### Section B. Monitoring Procedures

#### 1. Representative Samples

Samples and measurements taken as required herein shall be representative of the volume and nature of the monitored discharge.

#### 2. Test Procedures

Test procedures for the analysis of pollutants shall conform to regulations promulgated pursuant to Section 304(h) of the Clean Water Act (40 CFR Part 136 – Guidelines Establishing Test Procedures for the Analysis of Pollutants), unless specified otherwise in this permit. **Test procedures used shall be sufficiently sensitive to determine compliance with applicable effluent limitations.** Requests to use test procedures not promulgated under 40 CFR Part 136 for pollutant monitoring required by this permit shall be made in accordance with the Alternate Test Procedures regulations specified in 40 CFR 136.4. These requests shall be submitted to the Manager of the Permits Section, Water Resources Division, Michigan Department of Environment, Great Lakes, and Energy, P.O. Box 30458, Lansing, Michigan, 48909-7958. The permittee may use such procedures upon approval.

The permittee shall periodically calibrate and perform maintenance procedures on all analytical instrumentation at intervals to ensure accuracy of measurements. The calibration and maintenance shall be performed as part of the permittee's laboratory Quality Assurance/Quality Control program.

#### 3. Instrumentation

The permittee shall periodically calibrate and perform maintenance procedures on all monitoring instrumentation at intervals to ensure accuracy of measurements.

#### 4. Recording Results

For each measurement or sample taken pursuant to the requirements of this permit, the permittee shall record the following information: 1) the exact place, date, and time of measurement or sampling; 2) the person(s) who performed the measurement or sample collection; 3) the dates the analyses were performed; 4) the person(s) who performed the analyses; 5) the analytical techniques or methods used; 6) the date of and person responsible for equipment calibration; and 7) the results of all required analyses.

#### 5. Records Retention

All records and information resulting from the monitoring activities required by this permit including all records of analyses performed and calibration and maintenance of instrumentation and recordings from continuous monitoring instrumentation shall be retained for a minimum of three (3) years, or longer if requested by the Regional Administrator or the Department.

## PART II

### Section C. Reporting Requirements

#### 1. Start-Up Notification

If the permittee will not discharge during the first 60 days following the effective date of this permit, the permittee shall notify the Department within 14 days following the effective date of this permit, and then 60 days prior to the commencement of the discharge.

#### 2. Submittal Requirements for Self-Monitoring Data

Part 31 of the NREPA (specifically Section 324.3110(7)); and R 323.2155(2) of Part 21, Wastewater Discharge Permits, promulgated under Part 31 of the NREPA, allow the Department to specify the forms to be utilized for reporting the required self-monitoring data. Unless instructed on the effluent limitations page to conduct "Retained Self-Monitoring," the permittee shall submit self-monitoring data via the Department's MiWaters system.

The permittee shall utilize the information provided on the MiWaters website, located at <https://miwaters.deq.state.mi.us>, to access and submit the electronic forms. Both monthly summary and daily data shall be submitted to the Department no later than the 20<sup>th</sup> day of the month following each month of the authorized discharge period(s). The permittee may be allowed to submit the electronic forms after this date if the Department has granted an extension to the submittal date.

#### 3. Retained Self-Monitoring Requirements

If instructed on the effluent limits page (or otherwise authorized by the Department in accordance with the provisions of this permit) to conduct retained self-monitoring, the permittee shall maintain a year-to-date log of retained self-monitoring results and, upon request, provide such log for inspection to the staff of the Department. Retained self-monitoring results are public information and shall be promptly provided to the public upon request.

The permittee shall certify, in writing, to the Department, on or before January 10th (April 1st for animal feeding operation facilities) of each year, that: 1) all retained self-monitoring requirements have been complied with and a year-to-date log has been maintained; and 2) the application on which this permit is based still accurately describes the discharge. With this annual certification, the permittee shall submit a summary of the previous year's monitoring data. The summary shall include maximum values for samples to be reported as daily maximums and/or monthly maximums and minimum values for any daily minimum samples.

Retained self-monitoring may be denied to a permittee by notification in writing from the Department. In such cases, the permittee shall submit self-monitoring data in accordance with Part II.C.2., above. Such a denial may be rescinded by the Department upon written notification to the permittee. Reissuance or modification of this permit or reissuance or modification of an individual permittee's authorization to discharge shall not affect previous approval or denial for retained self-monitoring unless the Department provides notification in writing to the permittee.

#### 4. Additional Monitoring by Permittee

If the permittee monitors any pollutant at the location(s) designated herein more frequently than required by this permit, using approved analytical methods as specified above, the results of such monitoring shall be included in the calculation and reporting of the values required in the Discharge Monitoring Report. Such increased frequency shall also be indicated.

Monitoring required pursuant to Part 41 of the NREPA or Rule 35 of the Mobile Home Park Commission Act, 1987 PA 96, as amended, for assurance of proper facility operation, shall be submitted as required by the Department.

## 5. Compliance Dates Notification

Within 14 days of every compliance date specified in this permit, the permittee shall submit a *written* notification to the Department indicating whether or not the particular requirement was accomplished. If the requirement was not accomplished, the notification shall include an explanation of the failure to accomplish the requirement, actions taken or planned by the permittee to correct the situation, and an estimate of when the requirement will be accomplished. If a written report is required to be submitted by a specified date and the permittee accomplishes this, a separate written notification is not required.

## 6. Noncompliance Notification

Compliance with all applicable requirements set forth in the Clean Water Act, Parts 31 and 41 of the NREPA, and related regulations and rules is required. All instances of noncompliance shall be reported as follows:

- a. 24-Hour Reporting  
Any noncompliance which may endanger health or the environment (including maximum and/or minimum daily concentration discharge limitation exceedances) shall be reported, verbally, within 24 hours from the time the permittee becomes aware of the noncompliance. A written submission shall also be provided within five (5) days.
- b. Other Reporting  
The permittee shall report, in writing, all other instances of noncompliance not described in a. above at the time monitoring reports are submitted; or, in the case of retained self-monitoring, within five (5) days from the time the permittee becomes aware of the noncompliance.

Written reporting shall include: 1) a description of the discharge and cause of noncompliance; and 2) the period of noncompliance, including exact dates and times, or, if not yet corrected, the anticipated time the noncompliance is expected to continue, and the steps taken to reduce, eliminate and prevent recurrence of the noncomplying discharge.

## 7. Spill Notification

The permittee shall immediately report any release of any polluting material which occurs to the surface waters or groundwaters of the state, unless the permittee has determined that the release is not in excess of the threshold reporting quantities specified in the Part 5 Rules (R 324.2001 through R 324.2009 of the Michigan Administrative Code), by calling the Department at the number indicated on the second page of this permit (or, if this is a general permit, on the COC); or, if the notice is provided after regular working hours, call the Department's 24-hour Pollution Emergency Alerting System telephone number, 1-800-292-4706 (calls from **out-of-state** call 1-517-373-7660).

Within ten (10) days of the release, the permittee shall submit to the Department a full written explanation as to the cause of the release, the discovery of the release, response (clean-up and/or recovery) measures taken, and preventive measures taken or a schedule for completion of measures to be taken to prevent reoccurrence of similar releases.

## 8. Upset Noncompliance Notification

If a process "upset" (defined as an exceptional incident in which there is unintentional and temporary noncompliance with technology-based permit effluent limitations because of factors beyond the reasonable control of the permittee) has occurred, the permittee who wishes to establish the affirmative defense of upset shall notify the Department by telephone within 24 hours of becoming aware of such conditions; and within five (5) days, provide in writing, the following information:

- a. that an upset occurred and that the permittee can identify the specific cause(s) of the upset;
- b. that the permitted wastewater treatment facility was, at the time, being properly operated and maintained (note that an upset does not include noncompliance to the extent caused by operational error, improperly designed treatment facilities, inadequate treatment facilities, lack of preventive maintenance, or careless or improper operation); and
- c. that the permittee has specified and taken action on all responsible steps to minimize or correct any adverse impact in the environment resulting from noncompliance with this permit.

No determination made during administrative review of claims that noncompliance was caused by upset, and before an action for noncompliance, is final administrative action subject to judicial review.

In any enforcement proceedings, the permittee, seeking to establish the occurrence of an upset, has the burden of proof.

## 9. Bypass Prohibition and Notification

- a. Bypass Prohibition  
Bypass is prohibited, and the Department may take an enforcement action, unless:
  - 1) bypass was unavoidable to prevent loss of life, personal injury, or severe property damage;
  - 2) there were no feasible alternatives to the bypass, such as the use of auxiliary treatment facilities, retention of untreated wastes, or maintenance during normal periods of equipment downtime. This condition is not satisfied if adequate backup equipment should have been installed in the exercise of reasonable engineering judgment to prevent a bypass; and
  - 3) the permittee submitted notices as required under 9.b. or 9.c. below.
- b. Notice of Anticipated Bypass  
If the permittee knows in advance of the need for a bypass, it shall submit prior notice to the Department, if possible at least ten (10) days before the date of the bypass, and provide information about the anticipated bypass as required by the Department. The Department may approve an anticipated bypass, after considering its adverse effects, if it will meet the three (3) conditions listed in 9.a. above.
- c. Notice of Unanticipated Bypass  
The permittee shall submit notice to the Department of an unanticipated bypass by calling the Department at the number indicated on the second page of this permit (if the notice is provided after regular working hours, call: 1-800-292-4706) as soon as possible, but no later than 24 hours from the time the permittee becomes aware of the circumstances.

- d. **Written Report of Bypass**  
A written submission shall be provided within five (5) working days of commencing any bypass to the Department, and at additional times as directed by the Department. The written submission shall contain a description of the bypass and its cause; the period of bypass, including exact dates and times, and if the bypass has not been corrected, the anticipated time it is expected to continue; steps taken or planned to reduce, eliminate, and prevent reoccurrence of the bypass; and other information as required by the Department.
- e. **Bypass Not Exceeding Limitations**  
The permittee may allow any bypass to occur which does not cause effluent limitations to be exceeded, but only if it also is for essential maintenance to ensure efficient operation. These bypasses are not subject to the provisions of 9.a., 9.b., 9.c., and 9.d., above. This provision does not relieve the permittee of any notification responsibilities under Part II.C.11. of this permit.
- f. **Definitions**
- 1) Bypass means the intentional diversion of waste streams from any portion of a treatment facility.
  - 2) Severe property damage means substantial physical damage to property, damage to the treatment facilities which causes them to become inoperable, or substantial and permanent loss of natural resources which can reasonably be expected to occur in the absence of a bypass. Severe property damage does not mean economic loss caused by delays in production.

## 10. Bioaccumulative Chemicals of Concern (BCC)

Consistent with the requirements of R 323.1098 and R 323.1215 of the Michigan Administrative Code, the permittee is prohibited from undertaking any action that would result in a lowering of water quality from an increased loading of a BCC unless an increased use request and antidegradation demonstration have been submitted and approved by the Department.

## 11. Notification of Changes in Discharge

The permittee shall notify the Department, in writing, as soon as possible but no later than 10 days of knowing, or having reason to believe, that any activity or change has occurred or will occur which would result in the discharge of: 1) detectable levels of chemicals on the current Michigan Critical Materials Register, priority pollutants or hazardous substances set forth in 40 CFR 122.21, Appendix D, or the Pollutants of Initial Focus in the Great Lakes Water Quality Initiative specified in 40 CFR 132.6, Table 6, which were not acknowledged in the application or listed in the application at less than detectable levels; 2) detectable levels of any other chemical not listed in the application or listed at less than detection, for which the application specifically requested information; or 3) any chemical at levels greater than five times the average level reported in the complete application (see the first page of this permit, for the date(s) the complete application was submitted). Any other monitoring results obtained as a requirement of this permit shall be reported in accordance with the compliance schedules.

## 12. Changes in Facility Operations

Any anticipated action or activity, including but not limited to facility expansion, production increases, or process modification, which will result in new or increased loadings of pollutants to the receiving waters must be reported to the Department by a) submission of an increased use request (application) and all information required under R 323.1098 (Antidegradation) of the Water Quality Standards or b) by notice if the following conditions are met: 1) the action or activity will not result in a change in the types of wastewater discharged or result in a greater quantity of wastewater than currently authorized by this permit; 2) the action or activity will not result in violations of the effluent limitations specified in this permit; 3) the action or activity is not prohibited by the requirements of Part II.C.10.; and 4) the action or activity will not require notification pursuant to Part II.C.11. Following such notice, the permit or, if applicable, the facility's COC may be modified according to applicable laws and rules to specify and limit any pollutant not previously limited.

## 13. Transfer of Ownership or Control

In the event of any change in control or ownership of facilities from which the authorized discharge emanates, the permittee shall submit to the Department 30 days prior to the actual transfer of ownership or control a written agreement between the current permittee and the new permittee containing: 1) the legal name and address of the new owner; 2) a specific date for the effective transfer of permit responsibility, coverage and liability; and 3) a certification of the continuity of or any changes in operations, wastewater discharge, or wastewater treatment.

If the new permittee is proposing changes in operations, wastewater discharge, or wastewater treatment, the Department may propose modification of this permit in accordance with applicable laws and rules.

## 14. Operations and Maintenance Manual

For wastewater treatment facilities that serve the public (and are thus subject to Part 41 of the NREPA), Section 4104 of Part 41 and associated Rule 2957 of the Michigan Administrative Code allow the Department to require an Operations and Maintenance (O&M) Manual from the facility. An up-to-date copy of the O&M Manual shall be kept at the facility and shall be provided to the Department upon request. The Department may review the O&M Manual in whole or in part at its discretion and require modifications to it if portions are determined to be inadequate.

At a minimum, the O&M Manual shall include the following information: permit standards; descriptions and operation information for all equipment; staffing information; laboratory requirements; record keeping requirements; a maintenance plan for equipment; an emergency operating plan; safety program information; and copies of all pertinent forms, as-built plans, and manufacturer's manuals.

Certification of the existence and accuracy of the O&M Manual shall be submitted to the Department at least sixty days prior to start-up of a new wastewater treatment facility. Recertification shall be submitted sixty days prior to start-up of any substantial improvements or modifications made to an existing wastewater treatment facility.



## 15. Signatory Requirements

All applications, reports, or information submitted to the Department in accordance with the conditions of this permit and that require a signature shall be signed and certified as described in the Clean Water Act and the NREPA.

The Clean Water Act provides that any person who knowingly makes any false statement, representation, or certification in any record or other document submitted or required to be maintained under this permit, including monitoring reports or reports of compliance or noncompliance, shall, upon conviction, be punished by a fine of not more than \$10,000 per violation, or by imprisonment for not more than 6 months per violation, or by both.

The NREPA (Section 3115(2)) provides that a person who at the time of the violation knew or should have known that he or she discharged a substance contrary to this part, or contrary to a permit, COC, or order issued or rule promulgated under this part, or who intentionally makes a false statement, representation, or certification in an application for or form pertaining to a permit or COC or in a notice or report required by the terms and conditions of an issued permit or COC, or who intentionally renders inaccurate a monitoring device or record required to be maintained by the Department, is guilty of a felony and shall be fined not less than \$2,500.00 or more than \$25,000.00 for each violation. The court may impose an additional fine of not more than \$25,000.00 for each day during which the unlawful discharge occurred. If the conviction is for a violation committed after a first conviction of the person under this subsection, the court shall impose a fine of not less than \$25,000.00 per day and not more than \$50,000.00 per day of violation. Upon conviction, in addition to a fine, the court in its discretion may sentence the defendant to imprisonment for not more than 2 years or impose probation upon a person for a violation of this part. With the exception of the issuance of criminal complaints, issuance of warrants, and the holding of an arraignment, the circuit court for the county in which the violation occurred has exclusive jurisdiction. However, the person shall not be subject to the penalties of this subsection if the discharge of the effluent is in conformance with and obedient to a rule, order, permit, or COC of the Department. In addition to a fine, the attorney general may file a civil suit in a court of competent jurisdiction to recover the full value of the injuries done to the natural resources of the state and the costs of surveillance and enforcement by the state resulting from the violation.

## 16. Electronic Reporting

Upon notice by the Department that electronic reporting tools are available for specific reports or notifications, the permittee shall submit electronically all such reports or notifications as required by this permit, on forms provided by the Department.

## PART II

### Section D. Management Responsibilities

#### 1. Duty to Comply

All discharges authorized herein shall be consistent with the terms and conditions of this permit. The discharge of any pollutant identified in this permit, more frequently than, or at a level in excess of, that authorized, shall constitute a violation of the permit.

It is the duty of the permittee to comply with all the terms and conditions of this permit. Any noncompliance with the Effluent Limitations, Special Conditions, or terms of this permit constitutes a violation of the NREPA and/or the Clean Water Act and constitutes grounds for enforcement action; for permit or Certificate of Coverage (COC) termination, revocation and reissuance, or modification; or denial of an application for permit or COC renewal.

It shall not be a defense for a permittee in an enforcement action that it would have been necessary to halt or reduce the permitted activity in order to maintain compliance with the conditions of this permit.

#### 2. Operator Certification

The permittee shall have the waste treatment facilities under direct supervision of an operator certified at the appropriate level for the facility certification by the Department, as required by Sections 3110 and 4104 of the NREPA. Permittees authorized to discharge storm water shall have the storm water treatment and/or control measures under direct supervision of a storm water operator certified by the Department, as required by Section 3110 of the NREPA.

#### 3. Facilities Operation

The permittee shall, at all times, properly operate and maintain all treatment or control facilities or systems installed or used by the permittee to achieve compliance with the terms and conditions of this permit. Proper operation and maintenance includes adequate laboratory controls and appropriate quality assurance procedures.

#### 4. Power Failures

In order to maintain compliance with the effluent limitations of this permit and prevent unauthorized discharges, the permittee shall either:

- a. provide an alternative power source sufficient to operate facilities utilized by the permittee to maintain compliance with the effluent limitations and conditions of this permit; or
- b. upon the reduction, loss, or failure of one or more of the primary sources of power to facilities utilized by the permittee to maintain compliance with the effluent limitations and conditions of this permit, the permittee shall halt, reduce or otherwise control production and/or all discharge in order to maintain compliance with the effluent limitations and conditions of this permit.

#### 5. Adverse Impact

The permittee shall take all reasonable steps to minimize or prevent any adverse impact to the surface waters or groundwaters of the state resulting from noncompliance with any effluent limitation specified in this permit including, but not limited to, such accelerated or additional monitoring as necessary to determine the nature and impact of the discharge in noncompliance.

## 6. Containment Facilities

The permittee shall provide facilities for containment of any accidental losses of polluting materials in accordance with the requirements of the Part 5 Rules (R 324.2001 through R 324.2009 of the Michigan Administrative Code). For a POTW, these facilities shall be approved under Part 41 of the NREPA.

## 7. Waste Treatment Residues

Residuals (i.e. solids, sludges, biosolids, filter backwash, scrubber water, ash, grit, or other pollutants or wastes) removed from or resulting from treatment or control of wastewaters, including those that are generated during treatment or left over after treatment or control has ceased, shall be disposed of in an environmentally compatible manner and according to applicable laws and rules. These laws may include, but are not limited to, the NREPA, Part 31 for protection of water resources, Part 55 for air pollution control, Part 111 for hazardous waste management, Part 115 for solid waste management, Part 121 for liquid industrial wastes, Part 301 for protection of inland lakes and streams, and Part 303 for wetlands protection. Such disposal shall not result in any unlawful pollution of the air, surface waters or groundwaters of the state.

## 8. Right of Entry

The permittee shall allow the Department, any agent appointed by the Department, or the Regional Administrator, upon the presentation of credentials and, for animal feeding operation facilities, following appropriate biosecurity protocols:

- a. to enter upon the permittee's premises where an effluent source is located or any place in which records are required to be kept under the terms and conditions of this permit; and
- b. at reasonable times to have access to and copy any records required to be kept under the terms and conditions of this permit; to inspect process facilities, treatment works, monitoring methods and equipment regulated or required under this permit; and to sample any discharge of pollutants.

## 9. Availability of Reports

Except for data determined to be confidential under Section 308 of the Clean Water Act and Rule 2128 (R 323.2128 of the Michigan Administrative Code), all reports prepared in accordance with the terms of this permit, shall be available for public inspection at the offices of the Department and the Regional Administrator. As required by the Clean Water Act, effluent data shall not be considered confidential. Knowingly making any false statement on any such report may result in the imposition of criminal penalties as provided for in Section 309 of the Clean Water Act and Sections 3112, 3115, 4106 and 4110 of the NREPA.

## 10. Duty to Provide Information

The permittee shall furnish to the Department, within a reasonable time, any information which the Department may request to determine whether cause exists for modifying, revoking and reissuing, or terminating this permit or the facility's COC, or to determine compliance with this permit. The permittee shall also furnish to the Department, upon request, copies of records required to be kept by this permit.

Where the permittee becomes aware that it failed to submit any relevant facts in a permit application, or submitted incorrect information in a permit application or in any report to the Department, it shall promptly submit such facts or information.

**PART II****Section E. Activities Not Authorized by This Permit****1. Discharge to the Groundwaters**

This permit does not authorize any discharge to the groundwaters. Such discharge may be authorized by a groundwater discharge permit issued pursuant to the NREPA.

**2. POTW Construction**

This permit does not authorize or approve the construction or modification of any physical structures or facilities at a POTW. Approval for the construction or modification of any physical structures or facilities at a POTW shall be by permit issued under Part 41 of the NREPA.

**3. Civil and Criminal Liability**

Except as provided in permit conditions on "Bypass" (Part II.C.9. pursuant to 40 CFR 122.41(m)), nothing in this permit shall be construed to relieve the permittee from civil or criminal penalties for noncompliance, whether or not such noncompliance is due to factors beyond the permittee's control, such as accidents, equipment breakdowns, or labor disputes.

**4. Oil and Hazardous Substance Liability**

Nothing in this permit shall be construed to preclude the institution of any legal action or relieve the permittee from any responsibilities, liabilities, or penalties to which the permittee may be subject under Section 311 of the Clean Water Act except as are exempted by federal regulations.

**5. State Laws**

Nothing in this permit shall be construed to preclude the institution of any legal action or relieve the permittee from any responsibilities, liabilities, or penalties established pursuant to any applicable state law or regulation under authority preserved by Section 510 of the Clean Water Act.

**6. Property Rights**

The issuance of this permit does not convey any property rights in either real or personal property, or any exclusive privileges, nor does it authorize violation of any federal, state or local laws or regulations, nor does it obviate the necessity of obtaining such permits, including any other Department of Environment, Great Lakes, and Energy permits, or approvals from other units of government as may be required by law.



GRETCHEN WHITMER  
GOVERNOR

STATE OF MICHIGAN  
DEPARTMENT OF  
ENVIRONMENT, GREAT LAKES, AND ENERGY  
BAY CITY

**EGLE**  
LIESL EICHLER CLARK  
DIRECTOR

March 30, 2021

SENT VIA E-MAIL: [bbarringer@easttawas.com](mailto:bbarringer@easttawas.com)  
[ahorning@tawascity.org](mailto:ahorning@tawascity.org)

Mr. Brent Barringer, City Manager  
City of East Tawas  
Tawas Utility Authority  
760 Newman Street  
P.O. Box 672  
East Tawas, Michigan 48730

Ms. Annge Horning, City Manager  
City of Tawas City  
Tawas Utility Authority  
760 Newman Street  
P.O. Box 672  
East Tawas, Michigan 48730

Dear Mr. Barringer and Ms. Horning:

SUBJECT: Violation Notice No. VN-011588  
National Pollutant Discharge Elimination System (NPDES) Permit No. MI0021091  
Designated Name: Tawas Utility Authority WWTP

On October 5, 2020, staff of the Department of Environment, Great Lakes, and Energy (EGLE), Water Resources Division (WRD), conducted a Reconnaissance Inspection of Tawas Utility Authority (TUA) Wastewater Treatment Plant (WWTP), located at 810 West Franklin Street, East Tawas, Michigan. The purpose of the inspection was to evaluate the facility's compliance with Part 31, Water Resources Protection, of the Natural Resources and Environmental Protection Act, 1994 PA 451, as amended; and the NPDES Permit No. MI0021091, issued on October 2, 2013, effective November 1, 2013.

Ms. Catherine Winn and Mr. Eric Stein, both with F&V Operations (FVOP), participated in the inspection, which included an interview, records review, and site inspection.

The WRD has identified, and FVOP has reported, numerous monitoring violations occurring between September 2018, the date of the last inspection, and October 2020. The violations, which are detailed in Attachment 1, list an ongoing occurrence of Total Suspended Solids (TSS) and Fecal Coliform (Fecal) exceedances via Outfall 001. These monitoring results are violations of your permit.

As TUA is aware, the WWTP is an aging plant which is in need of significant upgrades, many of which can be attributed to the permit exceedances the plant is currently experiencing.

401 KETCHUM STREET • SUITE B • BAY CITY, MICHIGAN 48708  
[www.michigan.gov/EGLE](http://www.michigan.gov/EGLE) • (989) 894-6200

The WWTP, which has not received any significant upgrades since its last expansion in 1989, has only seen a short list of improvements which have been limited to ongoing maintenance and repairs of existing aging assets.

The TUA's Asset Management Program (AMP), provided to EGLE in 2017, outlines an extensive list of Capital Improvement Projects, as well as a significant list of immediate concerns. According to the AMP, the condition of these assets ranges from good to very poor and notes that many assets have reached the end of their useful life.

Between 2017 and 2020, the TUA has only documented three improvements to the WWTP according to the 2020 AMP annual report. This list of improvements includes the primary clarifier drive replacement, primary clarifier mechanism replacement, and primary digester mixer replacement. While all three of these items were listed as either an immediate concern or as an improvement project, these items were only addressed after the systems had failed.

To date, the list of significant concerns remains largely unchanged between 2017 and 2020, going from a list of 19 items to list of 15 items. Just as concerning, the list of 1-5 Year Capital Improvement Projects identified 20 projects in 2017, with 17 of these original projects still identified as incomplete on the same list under the 2020 AMP.

As outlined in all TUA AMPs, the goal of the Asset Management Plan is to meet a required level of service in the most cost-effective way through the operation, maintenance, and replacement/rehabilitation of assets to provide consistent wastewater treatment and environmental compliance. Based on the information gathered during site inspections, the permit exceedances identified in Discharge Monitoring Reports (DMR), and the lack of significant treatment system improvements or upgrades, it is clear that the TUA has failed to provide consistent wastewater treatment and environmental compliance.

The violations identified in this Violation Notice have been reoccurring and are violations of Part 31 of the NREPA, and the NPDES Permit No. MI0021091.

The concerns identified in this Violation Notice were previously addressed in the Violation Notice VN-005877 dated July 17, 2014. The VN-005877 identifies several treatment units within the WWTP which were not being properly maintained and were in need of repair or replacement. At that same time, the TUA had just begun development of their AMP and proceeded to add these treatment systems to the list of immediate concerns or improvement projects. To date, some of these same systems are still listed as in need of replacement or repair.

Tawas Utility Authority WWTP should take immediate action to achieve and maintain compliance with the terms and conditions of Part 31 and the NPDES Permit No. MI0021091.

Please submit a response to this office by **May 3, 2021**. At a minimum, the response shall include:

1. Discuss what immediate steps will be taken to address the ongoing violations listed in Attachment No. 1.
2. A schedule for completion of Year 1-5 Capital Improvement projects.

3. A significant cost is anticipated for the completion of the 17 remaining original capital improvement projects identified under the facility's AMP. Please identify anticipated funding sources for the remaining capital improvement projects, including but not limited to federal/state loans, grants, and etc.
4. A plan to address the remaining 15 items of significant concern.
5. The District was recently informed that TUA has hired new management for the plant which is scheduled to replace F&V Operations beginning April 1, 2021. Please provide the details necessary to show that the new management is adequately staffed to carry out the operation, maintenance, repair, and testing functions required to ensure compliance with the terms and conditions of the permit. In addition, be sure to update the Facilities MiWaters account to reflect the changes in management.

If you have any factual information you would like us to consider regarding the violations identified in this Violation Notice, please provide them with your written response.

We anticipate and appreciate your cooperation in resolving this matter. Should you require further information regarding this Violation Notice or if you would like to arrange a meeting to discuss it, please contact me at [silerm@michigan.gov](mailto:silerm@michigan.gov); 989-439-3461; or Department of Environment, Great Lakes, and Energy, WRD, 401 Ketchum Street, Bay City, Michigan 48708-5430.

Sincerely,



Matthew Siler  
Environmental Quality Analyst

Attachment: Attachment No. 1 – Monitoring Violations

cc: Ms. Catherine Winn, F&V Operations, [cwinn@fv-operations.com](mailto:cwinn@fv-operations.com)  
Mr. Davis Roeser, EGLE

## Attachment 1

### Detailed List of Permit Exceedances

DMR Report	Violation Type	Description of Violation	Non-Compliance Date
Sep-20	DMR value exceeds Limit value (Permit)	DMR: 09/01/2020-09/30/2020, 001A, Final Effluent (1), Total Suspended Solids, Maximum 7-Day Average - Permit Limit: 45 mg/L; Value: 47, Comment: 'Process upset due to switching oxidation ditches for inspection and maintenance'	9/11/2020
Sep-20	DMR value exceeds Limit value (Permit)	DMR: 09/01/2020-09/30/2020, 001A, Final Effluent (1), Total Suspended Solids, Maximum 7-Day Average - Permit Limit: 45 mg/L; Value: 47, Comment: 'Process upset due to switching oxidation ditches for inspection and maintenance'	9/10/2020
Sep-20	DMR value exceeds Limit value (Permit)	DMR: 09/01/2020-09/30/2020, 001A, Final Effluent (1), Fecal Coliform, Max 7-Day Geometric Mean - Permit Limit: 400 #/100mL; Value: 600, Comment: 'Process upset due to switching oxidation ditches for inspection and maintenance'	9/9/2020
Sep-20	DMR value exceeds Limit value (Permit)	DMR: 09/01/2020-09/30/2020, 001A, Final Effluent (1), Total Suspended Solids, Maximum 7-Day Average - Permit Limit: 45 mg/L; Value: 53, Comment: 'Process upset due to switching oxidation ditches for inspection and maintenance'	9/9/2020
Sep-20	DMR value exceeds Limit value (Permit)	DMR: 09/01/2020-09/30/2020, 001A, Final Effluent (1), Total Suspended Solids, Maximum 7-Day Average - Permit Limit: 45 mg/L; Value: 53, Comment: 'Process upset due to switching oxidation ditches for inspection and maintenance'	9/8/2020
Sep-20	DMR value exceeds Limit value (Permit)	DMR: 09/01/2020-09/30/2020, 001A, Final Effluent (1), Total Suspended Solids, Maximum 7-Day Average - Permit Limit: 45 mg/L; Value: 96, Comment: 'Process upset due to switching oxidation ditches for inspection and maintenance'	9/7/2020
Sep-20	DMR value exceeds Limit value (Permit)	DMR: 09/01/2020-09/30/2020, 001A, Percent Removal (K), Total Suspended Solids Minimum % Removal, Minimum Monthly % Removal - Permit Limit: 85 %; Value: 83, Comment: 'Process upset due to switching oxidation ditches for inspection and maintenance September 1 - September 10, 2020.'	9/1/2020
May-20	DMR value exceeds Limit value (Permit)	DMR: 05/01/2020-05/31/2020, 001A, Final Effluent (1), Fecal Coliform, Max 7-Day Geometric Mean - Permit Limit: 400 #/100mL; Value: 641, Comment: 'Extremely high flows, inadequate contact time'	5/30/2020
May-20	DMR value exceeds Limit value (Permit)	DMR: 05/01/2020-05/31/2020, 001A, Final Effluent (1), Fecal Coliform, Max 7-Day Geometric Mean - Permit Limit: 400 #/100mL; Value: 641, Comment: 'Extremely high flows, inadequate contact time'	5/30/2020
May-20	DMR value exceeds Limit value (Permit)	DMR: 05/01/2020-05/31/2020, 001A, Final Effluent (1), Fecal Coliform, Max 7-Day Geometric Mean - Permit Limit: 400 #/100mL; Value: 641, Comment: 'Extremely high flows, inadequate contact time'	5/29/2020



## Attachment 1

### Detailed List of Permit Exceedances

May-20	DMR value exceeds Limit value (Permit)	DMR: 05/01/2020-05/31/2020, 001A, Final Effluent (1), Fecal Coliform, Max 7-Day Geometric Mean - Permit Limit: 400 #/100mL; Value: 641, Comment: 'Extremely high flows, inadequate contact time'	5/29/2020
May-20	DMR value exceeds Limit value (Permit)	DMR: 05/01/2020-05/31/2020, 001A, Final Effluent (1), Fecal Coliform, Max 7-Day Geometric Mean - Permit Limit: 400 #/100mL; Value: 1122, Comment: 'Extremely high flows, inadequate contact time'	5/28/2020
May-20	DMR value exceeds Limit value (Permit)	DMR: 05/01/2020-05/31/2020, 001A, Final Effluent (1), Fecal Coliform, Max 7-Day Geometric Mean - Permit Limit: 400 #/100mL; Value: 1122, Comment: 'Extremely high flows, inadequate contact time'	5/28/2020
May-20	DMR value exceeds Limit value (Permit)	DMR: 05/01/2020-05/31/2020, 001A, Final Effluent (1), Fecal Coliform, Max 7-Day Geometric Mean - Permit Limit: 400 #/100mL; Value: 2649, Comment: 'Extremely high flows, inadequate contact time'	5/27/2020
May-20	DMR value exceeds Limit value (Permit)	DMR: 05/01/2020-05/31/2020, 001A, Final Effluent (1), Fecal Coliform, Max 7-Day Geometric Mean - Permit Limit: 400 #/100mL; Value: 2649, Comment: 'Extremely high flows, inadequate contact time'	5/27/2020
May-20	DMR value exceeds Limit value (Permit)	DMR: 05/01/2020-05/31/2020, 001A, Final Effluent (1), Fecal Coliform, Max 7-Day Geometric Mean - Permit Limit: 400 #/100mL; Value: 6209, Comment: 'Extremely high flows, inadequate contact time'	5/26/2020
May-20	DMR value exceeds Limit value (Permit)	DMR: 05/01/2020-05/31/2020, 001A, Final Effluent (1), Fecal Coliform, Max 7-Day Geometric Mean - Permit Limit: 400 #/100mL; Value: 6209, Comment: 'Extremely high flows, inadequate contact time'	5/26/2020
May-20	DMR value exceeds Limit value (Permit)	DMR: 05/01/2020-05/31/2020, 001A, Final Effluent (1), Fecal Coliform, Max 7-Day Geometric Mean - Permit Limit: 400 #/100mL; Value: 19953, Comment: 'Extremely high flows, inadequate contact time'	5/25/2020
May-20	DMR value exceeds Limit value (Permit)	DMR: 05/01/2020-05/31/2020, 001A, Final Effluent (1), Fecal Coliform, Max 7-Day Geometric Mean - Permit Limit: 400 #/100mL; Value: 19953, Comment: 'Extremely high flows, inadequate contact time'	5/25/2020
May-20	DMR value exceeds Limit value (Permit)	DMR: 05/01/2020-05/31/2020, 001A, Final Effluent (1), Fecal Coliform, Max 7-Day Geometric Mean - Permit Limit: 400 #/100mL; Value: 19953, Comment: 'Extremely high flows, inadequate contact time'	5/24/2020
May-20	DMR value exceeds Limit value (Permit)	DMR: 05/01/2020-05/31/2020, 001A, Final Effluent (1), Fecal Coliform, Max 7-Day Geometric Mean - Permit Limit: 400 #/100mL; Value: 19953, Comment: 'Extremely high flows, inadequate contact time'	5/24/2020

## Attachment 1

### Detailed List of Permit Exceedances

May-20	DMR value exceeds Limit value (Permit)	DMR: 05/01/2020-05/31/2020, 001A, Final Effluent (1), Fecal Coliform, Max 7-Day Geometric Mean - Permit Limit: 400 #/100mL; Value: 19953, Comment: 'Extremely high flows, inadequate contact time'	5/23/2020
May-20	DMR value exceeds Limit value (Permit)	DMR: 05/01/2020-05/31/2020, 001A, Final Effluent (1), Fecal Coliform, Max 7-Day Geometric Mean - Permit Limit: 400 #/100mL; Value: 19953, Comment: 'Extremely high flows, inadequate contact time'	5/23/2020
May-20	DMR value exceeds Limit value (Permit)	DMR: 05/01/2020-05/31/2020, 001A, Final Effluent (1), Fecal Coliform, Max 7-Day Geometric Mean - Permit Limit: 400 #/100mL; Value: 19953, Comment: 'Extremely high flows, inadequate contact time'	5/22/2020
May-20	DMR value exceeds Limit value (Permit)	DMR: 05/01/2020-05/31/2020, 001A, Final Effluent (1), Fecal Coliform, Max 7-Day Geometric Mean - Permit Limit: 400 #/100mL; Value: 19953, Comment: 'Extremely high flows, inadequate contact time'	5/22/2020
May-20	DMR value exceeds Limit value (Permit)	DMR: 05/01/2020-05/31/2020, 001A, Final Effluent (1), Fecal Coliform, Max 7-Day Geometric Mean - Permit Limit: 400 #/100mL; Value: 14289, Comment: 'Extremely high flows, inadequate contact time'	5/21/2020
May-20	DMR value exceeds Limit value (Permit)	DMR: 05/01/2020-05/31/2020, 001A, Final Effluent (1), Fecal Coliform, Max 7-Day Geometric Mean - Permit Limit: 400 #/100mL; Value: 14289, Comment: 'Extremely high flows, inadequate contact time'	5/21/2020
May-20	DMR value exceeds Limit value (Permit)	DMR: 05/01/2020-05/31/2020, 001A, Final Effluent (1), Fecal Coliform, Max 7-Day Geometric Mean - Permit Limit: 400 #/100mL; Value: 14289, Comment: 'Extremely high flows, inadequate contact time'	5/20/2020
May-20	DMR value exceeds Limit value (Permit)	DMR: 05/01/2020-05/31/2020, 001A, Final Effluent (1), Fecal Coliform, Max 7-Day Geometric Mean - Permit Limit: 400 #/100mL; Value: 14289, Comment: 'Extremely high flows, inadequate contact time'	5/20/2020
May-20	DMR value exceeds Limit value (Permit)	DMR: 05/01/2020-05/31/2020, 001A, Final Effluent (1), Fecal Coliform, Max Monthly Geometric Mean - Permit Limit: 200 #/100mL; Value: 19953, Comment: 'Extremely high flows, inadequate contact time.'	5/1/2020
May-20	DMR value exceeds Limit value (Permit)	DMR: 05/01/2020-05/31/2020, 001A, Final Effluent (1), Fecal Coliform, Max Monthly Geometric Mean - Permit Limit: 200 #/100mL; Value: 19953, Comment: 'Extremely high flows, inadequate contact time.'	5/1/2020
Mar-20	DMR value exceeds Limit value (Permit)	DMR: 03/01/2020-03/31/2020, 001A, Final Effluent (1), Total Suspended Solids, Maximum 7-Day Average - Permit Limit: 45 mg/L; Value: 56, Comment: 'De-chlorination feed pump failure.'	3/23/2020

## Attachment 1

### Detailed List of Permit Exceedances

Mar-20	DMR value exceeds Limit value (Permit)	DMR: 03/01/2020-03/31/2020, 001A, Final Effluent (1), Total Suspended Solids, Maximum 7-Day Average - Permit Limit: 45 mg/L; Value: 56, Comment: 'De-chlorination feed pump failure.'	3/22/2020
Mar-20	DMR value exceeds Limit value (Permit)	DMR: 03/01/2020-03/31/2020, 001A, Final Effluent (1), Total Suspended Solids, Maximum 7-Day Average - Permit Limit: 45 mg/L; Value: 62, Comment: 'De-chlorination feed pump failure.'	3/21/2020
Mar-20	DMR value exceeds Limit value (Permit)	DMR: 03/01/2020-03/31/2020, 001A, Final Effluent (1), Fecal Coliform, Max 7-Day Geometric Mean - Permit Limit: 400 #/100mL; Value: 430, Comment: 'De-chlorination feed pump failure.'	3/18/2020
Mar-20	DMR value exceeds Limit value (Permit)	DMR: 03/01/2020-03/31/2020, 001A, Final Effluent (1), Fecal Coliform, Max 7-Day Geometric Mean - Permit Limit: 400 #/100mL; Value: 586, Comment: 'De-chlorination feed pump failure.'	3/17/2020
Mar-20	DMR value exceeds Limit value (Permit)	DMR: 03/01/2020-03/31/2020, 001A, Final Effluent (1), Fecal Coliform, Max 7-Day Geometric Mean - Permit Limit: 400 #/100mL; Value: 1795, Comment: 'De-chlorination feed pump failure.'	3/16/2020
Mar-20	DMR value exceeds Limit value (Permit)	DMR: 03/01/2020-03/31/2020, 001A, Final Effluent (1), Total Suspended Solids, Maximum 7-Day Average - Permit Limit: 45 mg/L; Value: 51, Comment: 'De-chlorination feed pump failure.'	3/16/2020
Mar-20	DMR value exceeds Limit value (Permit)	DMR: 03/01/2020-03/31/2020, 001A, Final Effluent (1), Fecal Coliform, Max 7-Day Geometric Mean - Permit Limit: 400 #/100mL; Value: 811, Comment: 'De-chlorination feed pump failure.'	3/15/2020
Mar-20	DMR value exceeds Limit value (Permit)	DMR: 03/01/2020-03/31/2020, 001A, Final Effluent (1), Total Suspended Solids, Maximum 7-Day Average - Permit Limit: 45 mg/L; Value: 51, Comment: 'De-chlorination feed pump failure.'	3/15/2020
Mar-20	DMR value exceeds Limit value (Permit)	DMR: 03/01/2020-03/31/2020, 001A, Final Effluent (1), Fecal Coliform, Max 7-Day Geometric Mean - Permit Limit: 400 #/100mL; Value: 811, Comment: 'De-chlorination feed pump failure.'	3/14/2020
Mar-20	DMR value exceeds Limit value (Permit)	DMR: 03/01/2020-03/31/2020, 001A, Final Effluent (1), Total Suspended Solids, Maximum 7-Day Average - Permit Limit: 45 mg/L; Value: 50, Comment: 'De-chlorination feed pump failure.'	3/14/2020
Mar-20	DMR value exceeds Limit value (Permit)	DMR: 03/01/2020-03/31/2020, 001A, Final Effluent (1), Total Suspended Solids, Maximum 7-Day Average - Permit Limit: 45 mg/L; Value: 80, Comment: 'De-chlorination feed pump failure.'	3/13/2020

## Attachment 1

### Detailed List of Permit Exceedances

Mar-20	DMR value exceeds Limit value (Permit)	DMR: 03/01/2020-03/31/2020, 001A, Final Effluent (1), Fecal Coliform, Max 7-Day Geometric Mean - Permit Limit: 400 #/100mL; Value: 811, Comment: 'De-chlorination feed pump failure.'	3/13/2020
Mar-20	DMR value exceeds Limit value (Permit)	DMR: 03/01/2020-03/31/2020, 001A, Final Effluent (1), Total Suspended Solids, Maximum 7-Day Average - Permit Limit: 45 mg/L; Value: 80, Comment: 'De-chlorination feed pump failure.'	3/12/2020
Mar-20	DMR value exceeds Limit value (Permit)	DMR: 03/01/2020-03/31/2020, 001A, Final Effluent (1), Fecal Coliform, Max 7-Day Geometric Mean - Permit Limit: 400 #/100mL; Value: 811, Comment: 'De-chlorination feed pump failure..'	3/12/2020
Mar-20	DMR value exceeds Limit value (Permit)	DMR: 03/01/2020-03/31/2020, 001A, Final Effluent (1), Fecal Coliform, Max 7-Day Geometric Mean - Permit Limit: 400 #/100mL; Value: 418, Comment: 'De-chlorination feed pump failure.'	3/11/2020
Mar-20	DMR value exceeds Limit value (Permit)	DMR: 03/01/2020-03/31/2020, 001A, Final Effluent (1), Total Suspended Solids, Maximum 7-Day Average - Permit Limit: 45 mg/L; Value: 80, Comment: 'De-chlorination feed pump failure.'	3/11/2020
Mar-20	DMR value exceeds Limit value (Permit)	DMR: 03/01/2020-03/31/2020, 001A, Final Effluent (1), Fecal Coliform, Max 7-Day Geometric Mean - Permit Limit: 400 #/100mL; Value: 514, Comment: 'De-chlorination feed pump failure.'	3/10/2020
Mar-20	DMR value exceeds Limit value (Permit)	DMR: 03/01/2020-03/31/2020, 001A, Final Effluent (1), Total Suspended Solids, Maximum 7-Day Average - Permit Limit: 45 mg/L; Value: 67, Comment: 'De-chlorination feed pump failure.'	3/10/2020
Mar-20	DMR value exceeds Limit value (Permit)	DMR: 03/01/2020-03/31/2020, 001A, Final Effluent (1), Fecal Coliform, Max 7-Day Geometric Mean - Permit Limit: 400 #/100mL; Value: 411, Comment: 'De-chlorination feed pump failure.'	3/9/2020
Mar-20	DMR value exceeds Limit value (Permit)	DMR: 03/01/2020-03/31/2020, 001A, Final Effluent (1), Total Suspended Solids, Maximum 7-Day Average - Permit Limit: 45 mg/L; Value: 46, Comment: 'De-chlorination feed pump failure.'	3/9/2020
Mar-20	DMR value exceeds Limit value (Permit)	DMR: 03/01/2020-03/31/2020, 001A, Final Effluent (1), Total Suspended Solids, Maximum 7-Day Average - Permit Limit: 45 mg/L; Value: 46, Comment: 'De-chlorination feed pump failure.'	3/8/2020
Mar-20	DMR value exceeds Limit value (Permit)	DMR: 03/01/2020-03/31/2020, 001A, Final Effluent (1), Total Suspended Solids, Maximum 7-Day Average - Permit Limit: 45 mg/L; Value: 54, Comment: 'De-chlorination feed pump failure.'	3/7/2020

## Attachment 1

### Detailed List of Permit Exceedances

Mar-20	DMR value exceeds Limit value (Permit)	DMR: 03/01/2020-03/31/2020, 001A, Final Effluent (1), Fecal Coliform, Max Monthly Geometric Mean - Permit Limit: 200 #/100mL; Value: 261, Comment: 'De-chlorination feed pump failure.'	3/1/2020
Mar-20	DMR value exceeds Limit value (Permit)	DMR: 03/01/2020-03/31/2020, 001A, Final Effluent (1), Total Suspended Solids, Maximum Monthly Average - Permit Limit: 30 mg/L; Value: 39, Comment: 'De-chlorination feed pump failure.'	3/1/2020
Mar-20	DMR value exceeds Limit value (Permit)	DMR: 03/01/2020-03/31/2020, 001A, Percent Removal (K), Total Suspended Solids Minimum % Removal, Minimum Monthly % Removal - Permit Limit: 85 %; Value: 35, Comment: 'De-chlorination feed pump failure.'	3/1/2020
Mar-20	DMR value exceeds Limit value (Permit)	DMR: 03/01/2020-03/31/2020, 001A, Percent Removal (K), CBOD5 Minimum % Removal, Minimum Monthly % Removal - Permit Limit: 85 %; Value: 82, Comment: 'De-chlorination feed pump failure.'	3/1/2020
Jan-20	DMR value exceeds Limit value (Permit)	DMR: 01/01/2020-01/31/2020, 001A, Final Effluent (1), Fecal Coliform, Max 7-Day Geometric Mean - Permit Limit: 400 #/100mL; Value: 577, Comment: 'Inadequate contact time due to high peak flows. Chemical feed rate was increased, but did not improve disinfection efficiency.'	1/30/2020
Jan-20	DMR value exceeds Limit value (Permit)	DMR: 01/01/2020-01/31/2020, 001A, Final Effluent (1), Fecal Coliform, Max 7-Day Geometric Mean - Permit Limit: 400 #/100mL; Value: 1079, Comment: 'Inadequate contact time due to high peak flows. Chemical feed rate was increased, but did not improve disinfection efficiency.'	1/29/2020
Jan-20	DMR value exceeds Limit value (Permit)	DMR: 01/01/2020-01/31/2020, 001A, Final Effluent (1), Fecal Coliform, Max 7-Day Geometric Mean - Permit Limit: 400 #/100mL; Value: 430, Comment: 'Inadequate contact time due to high peak flows. Chemical feed rate was increased, but did not improve disinfection efficiency.'	1/28/2020
Jan-20	DMR value exceeds Limit value (Permit)	DMR: 01/01/2020-01/31/2020, 001A, Final Effluent (1), Fecal Coliform, Max 7-Day Geometric Mean - Permit Limit: 400 #/100mL; Value: 655, Comment: 'Inadequate contact time due to high peak flows. Chemical feed rate was increased, but did not improve disinfection efficiency.'	1/16/2020
Jan-20	DMR value exceeds Limit value (Permit)	DMR: 01/01/2020-01/31/2020, 001A, Final Effluent (1), Fecal Coliform, Max 7-Day Geometric Mean - Permit Limit: 400 #/100mL; Value: 4519, Comment: 'Inadequate contact time due to high peak flows. Chemical feed rate was increased, but did not improve disinfection efficiency.'	1/15/2020
Jan-20	DMR value exceeds Limit value (Permit)	DMR: 01/01/2020-01/31/2020, 001A, Final Effluent (1), Fecal Coliform, Max 7-Day Geometric Mean - Permit Limit: 400 #/100mL; Value: 1072, Comment: 'Inadequate contact time due to high peak flows. Chemical feed rate was increased, but did not improve disinfection efficiency.'	1/14/2020
Jan-20	DMR value exceeds Limit value (Permit)	DMR: 01/01/2020-01/31/2020, 001A, Percent Removal (K), Total Suspended Solids Minimum % Removal, Minimum Monthly % Removal - Permit Limit: 85 %; Value: 84, Comment: 'High flows and dilute raw influent suspended solids concentrations affected the percent removal. Effluent suspended solids were in compliance with NPDES permit limits for concentration and loading.'	1/1/2020

## Attachment 1

### Detailed List of Permit Exceedances

Jun-19	DMR value exceeds Limit value (Permit)	DMR: 06/01/2019-06/30/2019, 001A, Final Effluent (1), Fecal Coliform, Max 7-Day Geometric Mean - Permit Limit: 400 #/100mL; Value: 713, Comment: 'High flows resulted in elevated fecal coliform levels on 6/12/, 6/13, and 6/14. Chlorine feed rates were increased to address the issue. Fecal coliform levels returned to normal on 6/18.'	6/19/2019
Jun-19	DMR value exceeds Limit value (Permit)	DMR: 06/01/2019-06/30/2019, 001A, Final Effluent (1), Fecal Coliform, Max 7-Day Geometric Mean - Permit Limit: 400 #/100mL; Value: 1178, Comment: 'High flows resulted in elevated fecal coliform levels on 6/12/, 6/13, and 6/14. Chlorine feed rates were increased to address the issue. Fecal coliform levels returned to normal on 6/18.'	6/18/2019
Jun-19	DMR value exceeds Limit value (Permit)	DMR: 06/01/2019-06/30/2019, 001A, Final Effluent (1), Fecal Coliform, Max 7-Day Geometric Mean - Permit Limit: 400 #/100mL; Value: 3631, Comment: 'High flows resulted in elevated fecal coliform levels on 6/12/, 6/13, and 6/14. Chlorine feed rates were increased to address the issue. Fecal coliform levels returned to normal on 6/18.'	6/17/2019
Jun-19	DMR value exceeds Limit value (Permit)	DMR: 06/01/2019-06/30/2019, 001A, Final Effluent (1), Fecal Coliform, Max 7-Day Geometric Mean - Permit Limit: 400 #/100mL; Value: 3631, Comment: 'High flows resulted in elevated fecal coliform levels on 6/12/, 6/13, and 6/14. Chlorine feed rates were increased to address the issue. Fecal coliform levels returned to normal on 6/18.'	6/16/2019
Jun-19	DMR value exceeds Limit value (Permit)	DMR: 06/01/2019-06/30/2019, 001A, Final Effluent (1), Fecal Coliform, Max 7-Day Geometric Mean - Permit Limit: 400 #/100mL; Value: 3631, Comment: 'High flows resulted in elevated fecal coliform levels on 6/12/, 6/13, and 6/14. Chlorine feed rates were increased to address the issue. Fecal coliform levels returned to normal on 6/18.'	6/15/2019
Jun-19	DMR value exceeds Limit value (Permit)	DMR: 06/01/2019-06/30/2019, 001A, Final Effluent (1), Fecal Coliform, Max 7-Day Geometric Mean - Permit Limit: 400 #/100mL; Value: 3631, Comment: 'High flows resulted in elevated fecal coliform levels on 6/12/, 6/13, and 6/14. Chlorine feed rates were increased to address the issue. Fecal coliform levels returned to normal on 6/18.'	6/14/2019
Jun-19	DMR value exceeds Limit value (Permit)	DMR: 06/01/2019-06/30/2019, 001A, Final Effluent (1), Fecal Coliform, Max 7-Day Geometric Mean - Permit Limit: 400 #/100mL; Value: 2825, Comment: 'High flows resulted in elevated fecal coliform levels on 6/12/, 6/13, and 6/14. Chlorine feed rates were increased to address the issue. Fecal coliform levels returned to normal on 6/18.'	6/13/2019
May-19	DMR value exceeds Limit value (Permit)	DMR: 05/01/2019-05/31/2019, 001A, Final Effluent (1), Fecal Coliform, Max 7-Day Geometric Mean - Permit Limit: 400 #/100mL; Value: 682, Comment: 'Continuous high flows and short detention time affecting chlorine contact. Chemical feed adjustments made.'	5/31/2019
Mar-19	DMR value exceeds Limit value (Permit)	DMR: 03/01/2019-03/31/2019, 001A, Final Effluent (1), Fecal Coliform, Max 7-Day Geometric Mean - Permit Limit: 400 #/100mL; Value: 405, Comment: 'High flows caused reduced chlorine contact time. Chemical feed adjustments made to compensate.'	3/25/2019

## **APPENDIX C**

### **ENVIRONMENTAL INFORMATION**



106 W. Allegan St. Suite 500  
Lansing, MI 48933  
O: 517.371.1200  
www.c2ae.com

Ms. Marcella Hadden, THPO  
Bay Mills Indian Community  
6650 E. Broadway  
Mt. Pleasant, Michigan 48858

Dear Mr. Johnson:

SUBJECT: Notice and Opportunity to Comment  
20-0112 Tawas WWTP  
City of East Tawas

C2AE, working on behalf of the City of East Tawas, is preparing an application to fund improvements to Tawas Waste Water Treatment Plant. This work is proposed for funding through the Michigan Department of Environmental Quality, State Revolving Fund/Drinking Water Revolving Fund, starting in fiscal year 2021. The proposed work consists of rehabilitation of existing anaerobic digesters and secondary clarifiers, installing new screening, improvements to the odor control, optimization of existing biological process, and HVAC upgrades. The project will be located in Iosco County, Town 22N Range 08E Section 20. See map for exact location. There are no National Registered properties in the Area of Potential Effects.

This notice and opportunity to comment is being sent to you to fulfill Section 106 of the National Historic Preservation Act review process, which requires a federal agency or applicant to consult with THPOs and federally recognized Indian tribes. The purpose of this notice is to give you an opportunity to have your interests and concerns considered. Should you have any comments on potential impacts to known religious and/or culturally significant properties in the area of the proposed project, please provide them to us within 30 days of this notice.

Sincerely,

Charles Anthony  
C2AE  
517-371-9166  
charles.anthony@c2ae.com



Mr. Charles Anthony II  
C2AE  
106 West Allegan Street, Suite 500  
Lansing, MI 48933  
O: 517-371-9166

March 18, 2021

**Re: Rare Species Review #2840 – City of East Tawas WWTP Upgrades, Iosco County, MI (T22N R8E Section 21).**

Mr. Anthony:

The location for the proposed project was checked against known localities for rare species and unique natural features, which are recorded in the Michigan Natural Features Inventory (MNFI) natural heritage database. This continuously updated database is a comprehensive source of existing data on Michigan's endangered, threatened, or otherwise significant plant and animal species, natural plant communities, and other natural features. Records in the database indicate that a qualified observer has documented the presence of special natural features. The absence of records in the database for a particular site may mean that the site has not been surveyed. The only way to obtain a definitive statement on the status of natural features is to have a competent biologist perform a complete field survey.

Under Act 451 of 1994, the Natural Resources and Environmental Protection Act, Part 365, Endangered Species Protection, “a person shall not take, possess, transport, ...fish, plants, and wildlife indigenous to the state and determined to be endangered or threatened,” unless first receiving an Endangered Species Permit from the Michigan Department of Natural Resources (MDNR), Wildlife Division. Responsibility to protect endangered and threatened species is not limited to the lists below. Other species may be present that have not been recorded in the database.



**MSU EXTENSION**

**Michigan Natural Features Inventory**

PO Box 13036  
Lansing MI 48901

(517) 284-6200  
Fax (517) 373-9566

mnfi.anr.msu.edu

SU is an affirmative-

Although several at-risk species have been documented within 1.5 miles of the project site, the occurrences are Historic and/or far removed from the location **so it is not likely that negative impacts will occur**. Keep in mind that MNFI cannot fully evaluate this project without visiting the project site. MNFI offers several levels of [Rare Species Reviews](#), including field surveys which I would be happy to discuss with you.

Sincerely,

*Michael A. Sanders*

Michael A. Sanders  
Environmental Review Specialist/Zoologist  
Michigan Natural Features Inventory

**Comments for Rare Species Review #2840:** It is important to note that it is the applicant’s responsibility to comply with both state and federal threatened and endangered species legislation. Therefore, if a state listed species occurs at a project site, and you think you need an endangered species permit please contact: Casey Reitz, Michigan DNR Wildlife Division, 517-284-6210, or [ReitzC@michigan.gov](mailto:ReitzC@michigan.gov). If a federally listed species is involved and, you think a permit is needed, please contact Carrie Tansy, Endangered Species Program, U.S. Fish and Wildlife Service, East Lansing office, 517-351-8375, or [Carrie\\_Tansy@fws.gov](mailto:Carrie_Tansy@fws.gov).

Please consult MNFI’s [Rare Species Explorer](#) for additional information on Michigan’s rare plants and animals.

**Table 1: Occurrences of threatened & endangered species within 1.5 miles of RSR #2840**

ELCAT	SNAME	SCOMNAME	USES	SPROT	G_RANK	S_RANK	FIRSTOBS	LASTOBS	EORANK
Animal	<i>Percina copelandi</i>	Channel darter		E	G4	S1	1930	1930-08-18	H
Animal	<i>Ligumia nasuta</i>	Eastern pondmussel		E	G4	S2	2000-03-09	2000-03-09	E
Animal	<i>Gavia immer</i>	Common loon		T	G5	S3	2019-05-31	2019-05-31	E
Plant	<i>Zizania aquatica</i>	Wild rice		T	G5	S2S3	2014-08	2019-08-06	B

**Comments for Table 1:**

No concerns. Occurrences are Historic and/or far removed from the proposed activity.

## **Codes to accompany Table 1:**

### **State Protection Status Code Definitions (SPROT)**

E: Endangered  
T: Threatened  
SC: Special concern

### **Federal Protection Status Code Definitions (USESA)**

LE = listed endangered  
LT = listed threatened  
LELT = partly listed endangered and partly listed threatened  
PDL = proposed delist  
E(S/A) = endangered based on similarities/appearance  
PS = partial status (federally listed in only part of its range)  
C = species being considered for federal status

### **Global Heritage Status Rank Definitions (GRANK)**

The priority assigned by [NatureServe](#)'s national office for data collection and protection based upon the element's status throughout its entire world-wide range. Criteria not based only on number of occurrences; other critical factors also apply. Note that ranks are frequently combined.

G1 = critically imperiled globally because of extreme rarity (5 or fewer occurrences range-wide or very few remaining individuals or acres) or because of some factor(s) making it especially vulnerable to extinction.

G2 = imperiled globally because of rarity (6 to 20 occurrences or few remaining individuals or acres) or because of some factor(s) making it very vulnerable to extinction throughout its range.

G3: Either very rare and local throughout its range or found locally (even abundantly at some of its locations) in a restricted range (e.g. a single western state, a physiographic region in the East) or because of other factor(s) making it vulnerable to extinction throughout its range; in terms of occurrences, in the range of 21 to 100.

G4: Apparently secure globally, though it may be quite rare in parts of its range, especially at the periphery.

G5: Demonstrably secure globally, though it may be quite rare in parts of its range, especially at the periphery.

Q: Taxonomy uncertain

### **State Heritage Status Rank Definitions (SRANK)**

The priority assigned by the Michigan Natural Features Inventory for data collection and protection based upon the element's status within the state. Criteria not based only on number of occurrences; other critical factors also apply. Note that ranks are frequently combined.

S1: Critically imperiled in the state because of extreme rarity (5 or fewer occurrences or very few remaining individuals or acres) or because of some factor(s) making it especially vulnerable to extirpation in the state.

S2: Imperiled in state because of rarity (6 to 20 occurrences or few remaining individuals or acres) or because of some factor(s) making it very vulnerable to extirpation from the state.

S3: Rare or uncommon in state (on the order of 21 to 100 occurrences).

S4 = apparently secure in state, with many occurrences.

S5 = demonstrably secure in state and essentially ineradicable under present conditions.

SX = apparently extirpated from state.

Rare Species Review #2840  
C2AE  
City of East Tawas WWTP Upgrades  
Iosco County, MI  
March 18, 2021

**For projects involving Federal funding or a Federal agency authorization**

The following information is provided to assist you with Section 7 compliance of the Federal Endangered Species Act (ESA). The ESA directs all Federal agencies "to work to conserve endangered and threatened species. Section 7 of the ESA, called "Interagency Cooperation," is the means by which Federal agencies ensure their actions, including those they authorize or fund, do not jeopardize the existence of any listed species."

The project falls within the range of five (5) federally listed/proposed species which have been identified by the U.S. Fish and Wildlife Service (USFWS) to occur in Iosco County, Michigan:

**Federally Endangered**

**Piping plover** – there appears to be suitable habitat within 1.5 miles of the proposed activity. In the Great Lakes region, the federal and state endangered piping plover (*Charadrius melodus*) prefers to nest and forage on sparse or non-vegetated sand-pebble beaches with less than 5% vegetative cover. Nests are simple depressions in the sand and are generally placed in level areas between the water's edge and the first dune. Associated bodies of water and interdunal wetlands enhance these areas by increasing food availability. Optimal foraging areas are especially crucial along Lake Superior, where shoreline and benthic invertebrate communities are known to be naturally sparse. While feeding, open shoreline is preferred to vegetated beach areas. Piping plovers begin arriving in mid-to late-April. The nesting season is under way by mid-May and lasts until mid-August.

*Management and Conservation* - this species is declining throughout the Midwest due to habitat destruction and disturbance. The nests are simple depressions in the sand and are difficult to see. People walking on the beach may inadvertently destroy nests. Dogs on the beach can be especially dangerous for chicks and adults. Piping plovers are protected under the Federal Endangered Species Act and are very sensitive to human disturbance. Please avoid activity along the shoreline in this compartment between May and September.

**Federally Threatened**

**Northern long-eared bat** - Northern long-eared bat (*Myotis septentrionalis*) numbers in the northeast US have declined up to 99 percent. Loss or degradation of summer habitat, wind turbines, disturbance to hibernacula, predation, and pesticides have contributed to declines in Northern long-eared bat populations. However, no other threat has been as severe to the decline as White-nose Syndrome (WNS). WNS is a fungus that thrives in the cold, damp conditions in caves and mines where bats hibernate. The disease is believed to disrupt the hibernation cycle by causing bats to repeatedly awake thereby depleting vital energy reserves. This species was federally listed in May 2015 primarily due to the threat from WNS.

Although no known hibernacula or roost trees have been documented within 1.5 miles of the project area, this activity occurs within the designated [WNS zone](#) (i.e., within 150 miles of positive counties/districts impacted by WNS). In addition, suitable habitat does exist in and outside of our 1.5-mile search buffer. The USFWS has prepared a [dichotomous key](#) to help determine if this action may cause prohibited take of this bat. Please consult the USFWS [Endangered Species Page](#) for more information.

Also called northern bat or northern myotis, this bat is distinguished from other *Myotis* species by its long ears. In Michigan, northern long-eared bats hibernate in abandoned mines and caves in the Upper Peninsula; they

also commonly hibernate in the Tippy Dam spillway in Manistee County. This species is a regional migrant with migratory distance largely determined by locations of suitable hibernacula sites.

Northern long-eared bats typically roost and forage in forested areas. During the summer, these bats roost singly or in colonies underneath bark, in cavities or in crevices of both living and dead trees. These bats seem to select roost trees based on suitability to retain bark or provide cavities or crevices. Common roost trees in southern lower Michigan included species of ash, elm, and maple. Foraging occurs primarily in areas along woodland edges, woodland clearings, and over small woodland ponds. Moths, beetles, and small flies are common food items. Like all temperate bats this species typically produces only 1-2 young per year.

*Management and Conservation:* When there are no known roost trees or hibernacula in the project area, we encourage you to conduct tree-cutting activities and prescribed burns in forested areas during October 1 through March 31 when possible, but you are not required by the ESA to do so. When that is not possible, we encourage you to remove trees prior to June 1 or after July 31, as that will help to protect young bats that may be in forested areas but are not yet able to fly.

**Rufa red knot** – there appears to be suitable habitat within our standard 1.5-mile search buffer. The rufa red knot (*Calidris canutus rufa*) is one of the longest-distance migrants in the animal kingdom, flying some 18,000 miles annually between its breeding grounds in the Canadian Arctic to the wintering grounds at the southern-most tip of South America. Primarily occurring along the Atlantic and Gulf coasts, small groups of this shorebird regularly use the interior of the United States such as the Great Lakes during the annual migration. The Great Lakes shorelines provide vital stopover habitat for resting and refueling during their long annual journey.

The largest concentration of rufa red knots is found in May in Delaware Bay, where the birds stop to gorge on the eggs of spawning horseshoe crabs; a spectacle attracting thousands of birdwatchers to the area. In just a few days, the birds nearly double their weight to prepare for the final leg of their long journey to the Arctic. This species may be especially vulnerable to climate change which affects coastal habitats due to rising sea levels.

*Management and Conservation* - applies to actions that occur along coastal areas during the Red Knot migratory window of MAY 1 - SEPTEMBER 30.

**Pitcher's thistle** – there does not appear to be suitable habitat within 1.5-miles of the project site. The federal and state threatened Pitcher's thistle (*Cirsium pitcheri*) grows on open sand dunes and occasionally on lag gravel associated with dunes. All of its habitats are along the Great Lakes shores, or in very close proximity. This monocarpic (once-flowering) plant produces a rosette that will mature to flowering in 2-8 years, after which the plant dies. Seeds germinate in June, and most seedlings (rosettes) appear within 1-3 meters of parent plants. The taproot of this thistle, which can reach 2 m in length, enhances its ability to survive the often-desiccating conditions of its dune habitat. Pitcher's thistle blooms from approximately late-June to early September.

*Management and Conservation* - Pitcher's thistle can be locally extirpated by destruction or major disturbance of its habitat (e.g. by shoreline development, vehicular or ORV traffic, heavy foot traffic and/or intensive recreation).

**Eastern massasauga rattlesnake (EMR)** – this project falls outside Tier 1 and Tier 2 EMR habitat as designated by the U.S. Fish & Wildlife Service (USFWS). Tier 1 represents areas known to be occupied by EMR or highly likely to be occupied; Tier 2 is habitat where EMR are likely to occur. The federally threatened and state special concern Eastern massasauga rattlesnake (*Sistrurus catenatus*) is Michigan's only venomous snake and found in a variety of wetland habitats including bogs, fens, shrub swamps, wet meadows, marshes, moist grasslands, wet prairies, and floodplain forests. Eastern massasaugas occur throughout the Lower Peninsula but are not

found in the Upper Peninsula. Populations in southern Michigan are typically associated with open wetlands, particularly prairie fens, while those in northern Michigan are better known from lowland coniferous forests, such as cedar swamps. These snakes normally overwinter in crayfish or small mammal burrows often close to the groundwater level and emerge in spring as water levels rise. During late spring, these snakes move into adjacent uplands they spend the warmer months foraging in shrubby fields and grasslands in search of mice and voles, their favorite food.

Often described as “shy and sluggish”, these snakes avoid human confrontation and are not prone to strike, preferring to leave the area when they are threatened. However, like any wild animal, they will protect themselves from anything they see as a potential predator. Their short fangs can easily puncture skin and they do possess potent venom. Like many snakes, the first human reaction may be to kill the snake, but it is important to remember that all snakes play vital roles in the ecosystem. Some may eat harmful insects. Others like the massasauga consider rodents a delicacy and help control their population. Snakes are also a part of a larger food web and can provide food to eagles, herons, and several mammals.

*Management and Conservation:* any sightings of these snakes should be reported to the Michigan Department of Natural Resources, Wildlife Division. If possible, a photo of the live snake is also recommended.

USFWS Section 7 Consultation Technical Assistance can be found at:

<https://www.fws.gov/midwest/endangered/section7/s7process/index.html>

The website offers step-by-step instructions to guide you through the Section 7 consultation process with prepared templates for documenting “no effect.” as well as requesting concurrence on "may affect, but not likely to adversely affect" determinations.

Please let us know if you have questions.

Mike Sanders  
Environmental Review Specialist/Zoologist  
[Sander75@msu.edu](mailto:Sander75@msu.edu)  
Cell: 517-980-5632

# Custom Soil Resource Report for **Iosco County, Michigan**





# Preface

---

Soil surveys contain information that affects land use planning in survey areas. They highlight soil limitations that affect various land uses and provide information about the properties of the soils in the survey areas. Soil surveys are designed for many different users, including farmers, ranchers, foresters, agronomists, urban planners, community officials, engineers, developers, builders, and home buyers. Also, conservationists, teachers, students, and specialists in recreation, waste disposal, and pollution control can use the surveys to help them understand, protect, or enhance the environment.

Various land use regulations of Federal, State, and local governments may impose special restrictions on land use or land treatment. Soil surveys identify soil properties that are used in making various land use or land treatment decisions. The information is intended to help the land users identify and reduce the effects of soil limitations on various land uses. The landowner or user is responsible for identifying and complying with existing laws and regulations.

Although soil survey information can be used for general farm, local, and wider area planning, onsite investigation is needed to supplement this information in some cases. Examples include soil quality assessments (<http://www.nrcs.usda.gov/wps/portal/nrcs/main/soils/health/>) and certain conservation and engineering applications. For more detailed information, contact your local USDA Service Center (<https://offices.sc.egov.usda.gov/locator/app?agency=nrcs>) or your NRCS State Soil Scientist ([http://www.nrcs.usda.gov/wps/portal/nrcs/detail/soils/contactus/?cid=nrcs142p2\\_053951](http://www.nrcs.usda.gov/wps/portal/nrcs/detail/soils/contactus/?cid=nrcs142p2_053951)).

Great differences in soil properties can occur within short distances. Some soils are seasonally wet or subject to flooding. Some are too unstable to be used as a foundation for buildings or roads. Clayey or wet soils are poorly suited to use as septic tank absorption fields. A high water table makes a soil poorly suited to basements or underground installations.

The National Cooperative Soil Survey is a joint effort of the United States Department of Agriculture and other Federal agencies, State agencies including the Agricultural Experiment Stations, and local agencies. The Natural Resources Conservation Service (NRCS) has leadership for the Federal part of the National Cooperative Soil Survey.

Information about soils is updated periodically. Updated information is available through the NRCS Web Soil Survey, the site for official soil survey information.

The U.S. Department of Agriculture (USDA) prohibits discrimination in all its programs and activities on the basis of race, color, national origin, age, disability, and where applicable, sex, marital status, familial status, parental status, religion, sexual orientation, genetic information, political beliefs, reprisal, or because all or a part of an individual's income is derived from any public assistance program. (Not all prohibited bases apply to all programs.) Persons with disabilities who require



alternative means for communication of program information (Braille, large print, audiotape, etc.) should contact USDA's TARGET Center at (202) 720-2600 (voice and TDD). To file a complaint of discrimination, write to USDA, Director, Office of Civil Rights, 1400 Independence Avenue, S.W., Washington, D.C. 20250-9410 or call (800) 795-3272 (voice) or (202) 720-6382 (TDD). USDA is an equal opportunity provider and employer.

# Contents

---

<b>Preface</b> .....	2
<b>How Soil Surveys Are Made</b> .....	5
<b>Soil Map</b> .....	8
Soil Map.....	9
Legend.....	10
Map Unit Legend.....	11
Map Unit Descriptions.....	11
Iosco County, Michigan.....	13
369—Deford muck.....	13
446B—Wurtsmith-Meehan-Urban land complex, 0 to 6 percent slopes.....	14
W—Water.....	16
<b>References</b> .....	17

# How Soil Surveys Are Made

---

Soil surveys are made to provide information about the soils and miscellaneous areas in a specific area. They include a description of the soils and miscellaneous areas and their location on the landscape and tables that show soil properties and limitations affecting various uses. Soil scientists observed the steepness, length, and shape of the slopes; the general pattern of drainage; the kinds of crops and native plants; and the kinds of bedrock. They observed and described many soil profiles. A soil profile is the sequence of natural layers, or horizons, in a soil. The profile extends from the surface down into the unconsolidated material in which the soil formed or from the surface down to bedrock. The unconsolidated material is devoid of roots and other living organisms and has not been changed by other biological activity.

Currently, soils are mapped according to the boundaries of major land resource areas (MLRAs). MLRAs are geographically associated land resource units that share common characteristics related to physiography, geology, climate, water resources, soils, biological resources, and land uses (USDA, 2006). Soil survey areas typically consist of parts of one or more MLRA.

The soils and miscellaneous areas in a survey area occur in an orderly pattern that is related to the geology, landforms, relief, climate, and natural vegetation of the area. Each kind of soil and miscellaneous area is associated with a particular kind of landform or with a segment of the landform. By observing the soils and miscellaneous areas in the survey area and relating their position to specific segments of the landform, a soil scientist develops a concept, or model, of how they were formed. Thus, during mapping, this model enables the soil scientist to predict with a considerable degree of accuracy the kind of soil or miscellaneous area at a specific location on the landscape.

Commonly, individual soils on the landscape merge into one another as their characteristics gradually change. To construct an accurate soil map, however, soil scientists must determine the boundaries between the soils. They can observe only a limited number of soil profiles. Nevertheless, these observations, supplemented by an understanding of the soil-vegetation-landscape relationship, are sufficient to verify predictions of the kinds of soil in an area and to determine the boundaries.

Soil scientists recorded the characteristics of the soil profiles that they studied. They noted soil color, texture, size and shape of soil aggregates, kind and amount of rock fragments, distribution of plant roots, reaction, and other features that enable them to identify soils. After describing the soils in the survey area and determining their properties, the soil scientists assigned the soils to taxonomic classes (units). Taxonomic classes are concepts. Each taxonomic class has a set of soil characteristics with precisely defined limits. The classes are used as a basis for comparison to classify soils systematically. Soil taxonomy, the system of taxonomic classification used in the United States, is based mainly on the kind and character of soil properties and the arrangement of horizons within the profile. After the soil

## Custom Soil Resource Report

scientists classified and named the soils in the survey area, they compared the individual soils with similar soils in the same taxonomic class in other areas so that they could confirm data and assemble additional data based on experience and research.

The objective of soil mapping is not to delineate pure map unit components; the objective is to separate the landscape into landforms or landform segments that have similar use and management requirements. Each map unit is defined by a unique combination of soil components and/or miscellaneous areas in predictable proportions. Some components may be highly contrasting to the other components of the map unit. The presence of minor components in a map unit in no way diminishes the usefulness or accuracy of the data. The delineation of such landforms and landform segments on the map provides sufficient information for the development of resource plans. If intensive use of small areas is planned, onsite investigation is needed to define and locate the soils and miscellaneous areas.

Soil scientists make many field observations in the process of producing a soil map. The frequency of observation is dependent upon several factors, including scale of mapping, intensity of mapping, design of map units, complexity of the landscape, and experience of the soil scientist. Observations are made to test and refine the soil-landscape model and predictions and to verify the classification of the soils at specific locations. Once the soil-landscape model is refined, a significantly smaller number of measurements of individual soil properties are made and recorded. These measurements may include field measurements, such as those for color, depth to bedrock, and texture, and laboratory measurements, such as those for content of sand, silt, clay, salt, and other components. Properties of each soil typically vary from one point to another across the landscape.

Observations for map unit components are aggregated to develop ranges of characteristics for the components. The aggregated values are presented. Direct measurements do not exist for every property presented for every map unit component. Values for some properties are estimated from combinations of other properties.

While a soil survey is in progress, samples of some of the soils in the area generally are collected for laboratory analyses and for engineering tests. Soil scientists interpret the data from these analyses and tests as well as the field-observed characteristics and the soil properties to determine the expected behavior of the soils under different uses. Interpretations for all of the soils are field tested through observation of the soils in different uses and under different levels of management. Some interpretations are modified to fit local conditions, and some new interpretations are developed to meet local needs. Data are assembled from other sources, such as research information, production records, and field experience of specialists. For example, data on crop yields under defined levels of management are assembled from farm records and from field or plot experiments on the same kinds of soil.

Predictions about soil behavior are based not only on soil properties but also on such variables as climate and biological activity. Soil conditions are predictable over long periods of time, but they are not predictable from year to year. For example, soil scientists can predict with a fairly high degree of accuracy that a given soil will have a high water table within certain depths in most years, but they cannot predict that a high water table will always be at a specific level in the soil on a specific date.

After soil scientists located and identified the significant natural bodies of soil in the survey area, they drew the boundaries of these bodies on aerial photographs and

## Custom Soil Resource Report

identified each as a specific map unit. Aerial photographs show trees, buildings, fields, roads, and rivers, all of which help in locating boundaries accurately.

# Soil Map

---

The soil map section includes the soil map for the defined area of interest, a list of soil map units on the map and extent of each map unit, and cartographic symbols displayed on the map. Also presented are various metadata about data used to produce the map, and a description of each soil map unit.

# Custom Soil Resource Report Soil Map



Soil Map may not be valid at this scale.

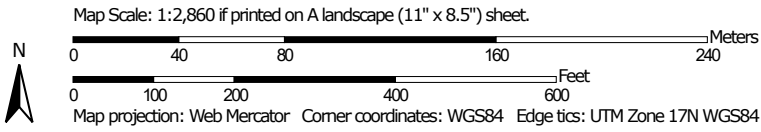

### MAP LEGEND

**Area of Interest (AOI)**

 Area of Interest (AOI)

**Soils**

 Soil Map Unit Polygons

 Soil Map Unit Lines

 Soil Map Unit Points

**Special Point Features**

-  Blowout
-  Borrow Pit
-  Clay Spot
-  Closed Depression
-  Gravel Pit
-  Gravelly Spot
-  Landfill
-  Lava Flow
-  Marsh or swamp
-  Mine or Quarry
-  Miscellaneous Water
-  Perennial Water
-  Rock Outcrop
-  Saline Spot
-  Sandy Spot
-  Severely Eroded Spot
-  Sinkhole
-  Slide or Slip
-  Sodic Spot

-  Spoil Area
-  Stony Spot
-  Very Stony Spot
-  Wet Spot
-  Other
-  Special Line Features

**Water Features**

 Streams and Canals

**Transportation**

-  Rails
-  Interstate Highways
-  US Routes
-  Major Roads
-  Local Roads

**Background**

 Aerial Photography

### MAP INFORMATION

The soil surveys that comprise your AOI were mapped at 1:15,800.

Warning: Soil Map may not be valid at this scale.

Enlargement of maps beyond the scale of mapping can cause misunderstanding of the detail of mapping and accuracy of soil line placement. The maps do not show the small areas of contrasting soils that could have been shown at a more detailed scale.

Please rely on the bar scale on each map sheet for map measurements.

Source of Map: Natural Resources Conservation Service  
 Web Soil Survey URL:  
 Coordinate System: Web Mercator (EPSG:3857)

Maps from the Web Soil Survey are based on the Web Mercator projection, which preserves direction and shape but distorts distance and area. A projection that preserves area, such as the Albers equal-area conic projection, should be used if more accurate calculations of distance or area are required.

This product is generated from the USDA-NRCS certified data as of the version date(s) listed below.

Soil Survey Area: Iosco County, Michigan  
 Survey Area Data: Version 15, Jun 3, 2020

Soil map units are labeled (as space allows) for map scales 1:50,000 or larger.

Date(s) aerial images were photographed: Dec 31, 2009—Nov 5, 2016

The orthophoto or other base map on which the soil lines were compiled and digitized probably differs from the background imagery displayed on these maps. As a result, some minor shifting of map unit boundaries may be evident.



## Map Unit Legend

Map Unit Symbol	Map Unit Name	Acres in AOI	Percent of AOI
369	Deford muck	29.1	74.8%
446B	Wurtsmith-Meehan-Urban land complex, 0 to 6 percent slopes	7.1	18.3%
W	Water	2.7	6.9%
<b>Totals for Area of Interest</b>		<b>38.9</b>	<b>100.0%</b>

## Map Unit Descriptions

The map units delineated on the detailed soil maps in a soil survey represent the soils or miscellaneous areas in the survey area. The map unit descriptions, along with the maps, can be used to determine the composition and properties of a unit.

A map unit delineation on a soil map represents an area dominated by one or more major kinds of soil or miscellaneous areas. A map unit is identified and named according to the taxonomic classification of the dominant soils. Within a taxonomic class there are precisely defined limits for the properties of the soils. On the landscape, however, the soils are natural phenomena, and they have the characteristic variability of all natural phenomena. Thus, the range of some observed properties may extend beyond the limits defined for a taxonomic class. Areas of soils of a single taxonomic class rarely, if ever, can be mapped without including areas of other taxonomic classes. Consequently, every map unit is made up of the soils or miscellaneous areas for which it is named and some minor components that belong to taxonomic classes other than those of the major soils.

Most minor soils have properties similar to those of the dominant soil or soils in the map unit, and thus they do not affect use and management. These are called noncontrasting, or similar, components. They may or may not be mentioned in a particular map unit description. Other minor components, however, have properties and behavioral characteristics divergent enough to affect use or to require different management. These are called contrasting, or dissimilar, components. They generally are in small areas and could not be mapped separately because of the scale used. Some small areas of strongly contrasting soils or miscellaneous areas are identified by a special symbol on the maps. If included in the database for a given area, the contrasting minor components are identified in the map unit descriptions along with some characteristics of each. A few areas of minor components may not have been observed, and consequently they are not mentioned in the descriptions, especially where the pattern was so complex that it was impractical to make enough observations to identify all the soils and miscellaneous areas on the landscape.

The presence of minor components in a map unit in no way diminishes the usefulness or accuracy of the data. The objective of mapping is not to delineate pure taxonomic classes but rather to separate the landscape into landforms or landform segments that have similar use and management requirements. The

## Custom Soil Resource Report

delineation of such segments on the map provides sufficient information for the development of resource plans. If intensive use of small areas is planned, however, onsite investigation is needed to define and locate the soils and miscellaneous areas.

An identifying symbol precedes the map unit name in the map unit descriptions. Each description includes general facts about the unit and gives important soil properties and qualities.

Soils that have profiles that are almost alike make up a *soil series*. Except for differences in texture of the surface layer, all the soils of a series have major horizons that are similar in composition, thickness, and arrangement.

Soils of one series can differ in texture of the surface layer, slope, stoniness, salinity, degree of erosion, and other characteristics that affect their use. On the basis of such differences, a soil series is divided into *soil phases*. Most of the areas shown on the detailed soil maps are phases of soil series. The name of a soil phase commonly indicates a feature that affects use or management. For example, Alpha silt loam, 0 to 2 percent slopes, is a phase of the Alpha series.

Some map units are made up of two or more major soils or miscellaneous areas. These map units are complexes, associations, or undifferentiated groups.

A *complex* consists of two or more soils or miscellaneous areas in such an intricate pattern or in such small areas that they cannot be shown separately on the maps. The pattern and proportion of the soils or miscellaneous areas are somewhat similar in all areas. Alpha-Beta complex, 0 to 6 percent slopes, is an example.

An *association* is made up of two or more geographically associated soils or miscellaneous areas that are shown as one unit on the maps. Because of present or anticipated uses of the map units in the survey area, it was not considered practical or necessary to map the soils or miscellaneous areas separately. The pattern and relative proportion of the soils or miscellaneous areas are somewhat similar. Alpha-Beta association, 0 to 2 percent slopes, is an example.

An *undifferentiated group* is made up of two or more soils or miscellaneous areas that could be mapped individually but are mapped as one unit because similar interpretations can be made for use and management. The pattern and proportion of the soils or miscellaneous areas in a mapped area are not uniform. An area can be made up of only one of the major soils or miscellaneous areas, or it can be made up of all of them. Alpha and Beta soils, 0 to 2 percent slopes, is an example.

Some surveys include *miscellaneous areas*. Such areas have little or no soil material and support little or no vegetation. Rock outcrop is an example.

## Iosco County, Michigan

### 369—Deford muck

#### Map Unit Setting

*National map unit symbol:* 6fm4  
*Elevation:* 580 to 1,030 feet  
*Mean annual precipitation:* 24 to 31 inches  
*Mean annual air temperature:* 33 to 54 degrees F  
*Frost-free period:* 80 to 150 days  
*Farmland classification:* Not prime farmland

#### Map Unit Composition

*Deford and similar soils:* 90 percent  
*Minor components:* 10 percent  
*Estimates are based on observations, descriptions, and transects of the mapunit.*

#### Description of Deford

##### Setting

*Landform:* Depressions on moraines, depressions on deltas, depressions on outwash plains, depressions on lake plains  
*Landform position (three-dimensional):* Talf  
*Down-slope shape:* Linear  
*Across-slope shape:* Linear  
*Parent material:* Less than 7 inches of organic material over sandy glaciofluvial deposits

##### Typical profile

*Oa - 0 to 5 inches:* muck  
*H2 - 5 to 80 inches:* sand

##### Properties and qualities

*Slope:* 0 to 2 percent  
*Depth to restrictive feature:* More than 80 inches  
*Drainage class:* Very poorly drained  
*Runoff class:* Negligible  
*Capacity of the most limiting layer to transmit water (Ksat):* Moderately high to high (0.20 to 5.95 in/hr)  
*Depth to water table:* About 0 inches  
*Frequency of flooding:* None  
*Frequency of ponding:* Frequent  
*Available water capacity:* Low (about 5.3 inches)

##### Interpretive groups

*Land capability classification (irrigated):* None specified  
*Land capability classification (nonirrigated):* 5w  
*Hydrologic Soil Group:* A/D  
*Ecological site:* F094AB023MI - Wet Sandy Depression  
*Hydric soil rating:* Yes

#### Minor Components

##### Finch

*Percent of map unit:* 4 percent  
*Landform:* Deltas, lake plains, moraines, outwash plains

## Custom Soil Resource Report

*Landform position (three-dimensional):* Rise  
*Down-slope shape:* Linear  
*Across-slope shape:* Linear  
*Hydric soil rating:* No

### **Au gres**

*Percent of map unit:* 3 percent  
*Landform:* Lake plains, deltas, outwash plains, moraines  
*Landform position (three-dimensional):* Rise  
*Down-slope shape:* Linear  
*Across-slope shape:* Linear  
*Hydric soil rating:* No

### **Tawas**

*Percent of map unit:* 3 percent  
*Landform:* Depressions on deltas, depressions on outwash plains, depressions on lake plains, depressions on moraines  
*Landform position (three-dimensional):* Dip  
*Down-slope shape:* Linear  
*Across-slope shape:* Linear  
*Hydric soil rating:* Yes

## **446B—Wurtsmith-Meehan-Urban land complex, 0 to 6 percent slopes**

### **Map Unit Setting**

*National map unit symbol:* 6fnx  
*Elevation:* 580 to 1,030 feet  
*Mean annual precipitation:* 24 to 31 inches  
*Mean annual air temperature:* 33 to 54 degrees F  
*Frost-free period:* 80 to 150 days  
*Farmland classification:* Not prime farmland

### **Map Unit Composition**

*Wurtsmith and similar soils:* 40 percent  
*Meehan and similar soils:* 30 percent  
*Urban land:* 20 percent  
*Minor components:* 10 percent  
*Estimates are based on observations, descriptions, and transects of the mapunit.*

### **Description of Wurtsmith**

#### **Setting**

*Landform:* Beach ridges on lake plains  
*Landform position (three-dimensional):* Rise  
*Down-slope shape:* Linear  
*Across-slope shape:* Linear  
*Parent material:* Sandy glaciofluvial deposits and/or lacustrine deposits

#### **Typical profile**

*H1 - 0 to 4 inches:* sand  
*H2 - 4 to 24 inches:* sand

## Custom Soil Resource Report

*H3 - 24 to 80 inches: sand*

### Properties and qualities

*Slope: 0 to 6 percent*

*Depth to restrictive feature: More than 80 inches*

*Drainage class: Moderately well drained*

*Runoff class: Negligible*

*Capacity of the most limiting layer to transmit water (Ksat): High to very high (5.95 to 19.98 in/hr)*

*Depth to water table: About 24 inches*

*Frequency of flooding: None*

*Frequency of ponding: None*

*Available water capacity: Low (about 3.9 inches)*

### Interpretive groups

*Land capability classification (irrigated): None specified*

*Land capability classification (nonirrigated): 4s*

*Hydrologic Soil Group: A*

*Ecological site: F094AB020MI - Acidic Sandy Depression*

*Hydric soil rating: No*

## Description of Meehan

### Setting

*Landform: Beach ridges on lake plains*

*Landform position (three-dimensional): Rise*

*Down-slope shape: Linear*

*Across-slope shape: Linear*

*Parent material: Sandy glaciofluvial deposits and/or glaciolacustrine deposits*

### Typical profile

*H1 - 0 to 3 inches: sand*

*H2 - 3 to 44 inches: sand*

*H3 - 44 to 80 inches: sand*

### Properties and qualities

*Slope: 0 to 3 percent*

*Depth to restrictive feature: More than 80 inches*

*Drainage class: Somewhat poorly drained*

*Runoff class: Negligible*

*Capacity of the most limiting layer to transmit water (Ksat): High to very high (5.95 to 19.98 in/hr)*

*Depth to water table: About 12 inches*

*Frequency of flooding: None*

*Frequency of ponding: None*

*Available water capacity: Low (about 4.7 inches)*

### Interpretive groups

*Land capability classification (irrigated): 4e*

*Land capability classification (nonirrigated): 4w*

*Hydrologic Soil Group: A/D*

*Ecological site: F094AB020MI - Acidic Sandy Depression*

*Hydric soil rating: No*

## Minor Components

### Deford

*Percent of map unit: 5 percent*

## Custom Soil Resource Report

*Landform:* Depressions on lake plains  
*Landform position (three-dimensional):* Talf  
*Down-slope shape:* Linear  
*Across-slope shape:* Linear  
*Hydric soil rating:* Yes

### **Grayling**

*Percent of map unit:* 5 percent  
*Landform:* Lake plains  
*Landform position (three-dimensional):* Rise  
*Down-slope shape:* Linear  
*Across-slope shape:* Linear  
*Hydric soil rating:* No

## **W—Water**

### **Map Unit Setting**

*National map unit symbol:* 6frd  
*Elevation:* 580 to 1,030 feet  
*Mean annual precipitation:* 24 to 31 inches  
*Mean annual air temperature:* 33 to 54 degrees F  
*Frost-free period:* 80 to 150 days  
*Farmland classification:* Not prime farmland

### **Map Unit Composition**

*Water:* 100 percent  
*Estimates are based on observations, descriptions, and transects of the mapunit.*

# References

---

- American Association of State Highway and Transportation Officials (AASHTO). 2004. Standard specifications for transportation materials and methods of sampling and testing. 24th edition.
- American Society for Testing and Materials (ASTM). 2005. Standard classification of soils for engineering purposes. ASTM Standard D2487-00.
- Cowardin, L.M., V. Carter, F.C. Golet, and E.T. LaRoe. 1979. Classification of wetlands and deep-water habitats of the United States. U.S. Fish and Wildlife Service FWS/OBS-79/31.
- Federal Register. July 13, 1994. Changes in hydric soils of the United States.
- Federal Register. September 18, 2002. Hydric soils of the United States.
- Hurt, G.W., and L.M. Vasilas, editors. Version 6.0, 2006. Field indicators of hydric soils in the United States.
- National Research Council. 1995. Wetlands: Characteristics and boundaries.
- Soil Survey Division Staff. 1993. Soil survey manual. Soil Conservation Service. U.S. Department of Agriculture Handbook 18. [http://www.nrcs.usda.gov/wps/portal/nrcs/detail/national/soils/?cid=nrcs142p2\\_054262](http://www.nrcs.usda.gov/wps/portal/nrcs/detail/national/soils/?cid=nrcs142p2_054262)
- Soil Survey Staff. 1999. Soil taxonomy: A basic system of soil classification for making and interpreting soil surveys. 2nd edition. Natural Resources Conservation Service, U.S. Department of Agriculture Handbook 436. [http://www.nrcs.usda.gov/wps/portal/nrcs/detail/national/soils/?cid=nrcs142p2\\_053577](http://www.nrcs.usda.gov/wps/portal/nrcs/detail/national/soils/?cid=nrcs142p2_053577)
- Soil Survey Staff. 2010. Keys to soil taxonomy. 11th edition. U.S. Department of Agriculture, Natural Resources Conservation Service. [http://www.nrcs.usda.gov/wps/portal/nrcs/detail/national/soils/?cid=nrcs142p2\\_053580](http://www.nrcs.usda.gov/wps/portal/nrcs/detail/national/soils/?cid=nrcs142p2_053580)
- Tiner, R.W., Jr. 1985. Wetlands of Delaware. U.S. Fish and Wildlife Service and Delaware Department of Natural Resources and Environmental Control, Wetlands Section.
- United States Army Corps of Engineers, Environmental Laboratory. 1987. Corps of Engineers wetlands delineation manual. Waterways Experiment Station Technical Report Y-87-1.
- United States Department of Agriculture, Natural Resources Conservation Service. National forestry manual. [http://www.nrcs.usda.gov/wps/portal/nrcs/detail/soils/home/?cid=nrcs142p2\\_053374](http://www.nrcs.usda.gov/wps/portal/nrcs/detail/soils/home/?cid=nrcs142p2_053374)
- United States Department of Agriculture, Natural Resources Conservation Service. National range and pasture handbook. <http://www.nrcs.usda.gov/wps/portal/nrcs/detail/national/landuse/rangepasture/?cid=stelprdb1043084>

## Custom Soil Resource Report

United States Department of Agriculture, Natural Resources Conservation Service. National soil survey handbook, title 430-VI. [http://www.nrcs.usda.gov/wps/portal/nrcs/detail/soils/scientists/?cid=nrcs142p2\\_054242](http://www.nrcs.usda.gov/wps/portal/nrcs/detail/soils/scientists/?cid=nrcs142p2_054242)

United States Department of Agriculture, Natural Resources Conservation Service. 2006. Land resource regions and major land resource areas of the United States, the Caribbean, and the Pacific Basin. U.S. Department of Agriculture Handbook 296. [http://www.nrcs.usda.gov/wps/portal/nrcs/detail/national/soils/?cid=nrcs142p2\\_053624](http://www.nrcs.usda.gov/wps/portal/nrcs/detail/national/soils/?cid=nrcs142p2_053624)

United States Department of Agriculture, Soil Conservation Service. 1961. Land capability classification. U.S. Department of Agriculture Handbook 210. [http://www.nrcs.usda.gov/Internet/FSE\\_DOCUMENTS/nrcs142p2\\_052290.pdf](http://www.nrcs.usda.gov/Internet/FSE_DOCUMENTS/nrcs142p2_052290.pdf)



## **APPENDIX D**

### **COST BASIS**



123 W. Main St., Suite 200  
 Gaylord, MI 49735  
 O: 989.732.8131

**Tawas Utilities Authority SRF Project Plan**

**OPINION OF COST FOR PROCESS CAPITAL IMPROVEMENTS**

<u>Description</u>	<u>Option 1</u>	<u>Option 2</u>
	<u>Upgrade Existing Systems</u>	<u>Eliminate Primary Clarifiers</u>
	<u>Anaerobic Digestion</u>	<u>Aerobic Digestion</u>
<b><u>Capital Costs</u></b>		
<b><u>Option 1 - Primary Clarification - Anaerobic Digestion</u></b>		
Primary Clarifier Rehabilitation	\$245,000	
Digester Rehabilitation	\$606,052	
<b><u>Option 2 - No Primary Clarification - Aerobic Digestion</u></b>		
Primary Clarifier Deletion		\$20,000
Digester Conversion to Aerobic		\$451,100
<b><u>Subtotals - Alternative Items</u></b>	<b><u>\$851,050</u></b>	<b><u>\$471,100</u></b>
<b><u>Common Elements</u></b>		
Headworks - Screening	\$903,000	\$903,000
Grit System Upgrade	\$556,000	\$556,000
Oxidation Ditch Rehabilitation	\$274,000	\$274,000
Secondary Clarifier Rehabilitation	\$329,000	\$329,000
RAS and WAS Improvements	\$200,000	\$200,000
Tertiary Filtration	\$1,157,000	\$1,157,000
UV Disinfection	\$774,000	\$774,000
Effluent Metering	\$33,000	\$33,000
Sludge Storage and Mixing	\$1,708,000	\$1,708,000
Building Upgrades	\$121,400	\$121,400
HVAC Systems Improvements	\$102,000	\$102,000
Electrical Improvements	\$688,000	\$688,000
SCADA System Upgrade	\$385,000	\$385,000
Structural, Safety, Other Improvements	\$279,000	\$279,000
<b><u>Subtotals - Common Items</u></b>	<b><u>\$7,509,400</u></b>	<b><u>\$7,509,400</u></b>
<b>Total Construction Cost</b>	<b>\$8,360,450</b>	<b>\$7,980,500</b>
Engineering Planning and Contingencies	\$2,508,100	\$2,394,200
Total Project Cost, Current Dollars	\$10,868,550	\$10,374,700
Escalation to 2023 Construction, 3% Per Year	\$652,110	\$622,480
<b>Opinion of Probable Project Cost, 2023 Construction</b>	<b>\$11,520,660</b>	<b>\$10,997,180</b>
<b><u>Cost Per REU with 20 Year Financing</u></b>		
Annual Debt Service	(\$696,095)	(\$664,466)
Interest Rate, Per OMB Guidance	1.875%	1.875%
<b>Cost Per REU at 2500 REU</b>	<b>(\$278)</b>	<b>(\$266)</b>
<b><u>Cost Per REU with 30 Year Financing</u></b>		
Annual Debt Service	(\$523,280)	(\$499,503)
Interest Rate	2.125%	2.125%
<b>Cost Per REU at 2500 REU</b>	<b>(\$209)</b>	<b>(\$200)</b>



123 W. Main St., Suite 200  
 Gaylord, MI 49735  
 O: 989.732.8131

**Tawas Utilities Authority SRF Project Plan**

**PRESENT WORTH VALUE CALCULATIONS 20 YEAR LIFE**

	<b>Alt. 1</b>	<b>Alt. 2</b>
<b>Capital Cost</b>	\$11,520,660	\$10,997,180
<b>O&amp;M</b>	\$30,119	\$25,527
<b>Interest (i)</b>	-0.50%	-0.50%
<b>Years (N)</b>	20	20
<b>Salvage</b>	\$4,793,031	\$4,575,243
<b>(1+i)<sup>N</sup></b>	0.9046	0.9046
<b>PW of O&amp;M</b>	<b>635,202</b>	<b>538,357</b>
<b>PW of Salvage</b>	<b>5,298,447</b>	<b>5,193,853</b>
<b>Present Worth</b>	<b>17,454,309</b>	<b>16,593,230</b>

**PRESENT WORTH VALUE CALCULATIONS 30 YEAR LIFE**

	<b>Alt. 1</b>	<b>Alt. 2</b>
<b>Capital Cost</b>	\$13,420,425	\$12,810,622
<b>O&amp;M</b>	\$30,119	\$25,527
<b>Interest (i)</b>	-0.50%	-0.50%
<b>Years (N)</b>	30	30
<b>Salvage</b>	\$6,068,968	\$5,793,204
<b>(1+i)<sup>N</sup></b>	0.8604	0.8604
<b>PW of O&amp;M</b>	<b>977,496</b>	<b>828,463</b>
<b>PW of Salvage</b>	<b>7,053,789</b>	<b>5,193,853</b>
<b>Present Worth</b>	<b>21,451,710</b>	<b>20,372,361</b>

**Formula:**

$$PV = \text{Capital Cost} + \text{Annual O\&M} \left[ \frac{(1+i)^N - 1}{i(1+i)^N} \right] + \text{Salvage} \left[ \frac{1}{(1+i)^N} \right]$$



123 W. Main St., Suite 200  
 Gaylord, MI 49735  
 O: 989.732.8131

PROJECT NO. 20-0112  
 BY: MPF  
 DATE: 3/5/21

**Tawas Utilities Authority SRF Project Plan**

**SALVAGE VALUE OF ALTERNATIVES**

		<u>Option 1</u>		<u>Option 2</u>	
		<u>Original Cost</u>	<u>Salvage Value</u>	<u>Original Cost</u>	<u>Salvage Value</u>
	<b>20 Year Planning Period</b>				
	Structures (40 Year Life)	\$8,803,527	\$4,401,764	\$8,403,507	\$4,201,754
	Piping and Valves (50 Year Life)	\$652,113	\$391,268	\$622,482	\$373,489
	Equipment (20 Year Life)	\$1,412,912	\$0	\$1,348,711	\$0
		\$10,868,552	\$4,793,032	\$10,374,700	\$4,575,243
	<b>30 Year Planning Period</b>				
	Structures (40 Year Life)	\$8,803,527	\$6,602,645	\$8,403,507	\$6,302,630
	Piping and Valves (50 Year Life)	\$652,113	\$391,268	\$622,482	\$373,489
	Equipment (20 Year Life)	\$1,412,912	\$0	\$1,348,711	\$0
	Replacement Cost, 20 Year Equipment	\$2,551,876	\$1,275,938	\$2,435,922	\$1,217,961
		\$13,420,428	\$8,269,851	\$12,810,622	\$7,894,080
	<b>Construction Subtotal</b>				
		\$10,868,552		\$10,374,700	

Replacement costs for 30 year analysis calculated based on original cost inflated at 3% per year.



123 W. Main St., Suite 200  
 Gaylord, MI 49735  
 O: 989.732.8131

**Tawas Utilities Authority SRF Project Plan**

**OPINION OF COST Operations and Maintenance**

**Option 1 - Primary Clarification - Anaerobic Digestion**

Staffing	Rate	Hrs/Day	Cost per Year
Operations Staff - Supervisor	\$75	0.1	\$2,737.50
Operations Staff - Supervisor	\$35	0.25	\$3,193.75
			<u>\$5,931.25</u>

Electrical & Utilities	HP	Hrs/Day	Annual Cost
Clarifier Drives	5.0	24.0	\$ 3,889.44
Sludge Pumps	8.0	6.0	\$ 1,555.78
Digester Mixer	10.0	24.0	\$ 7,778.88
Sludge Transfer Pumps	4.0	1.0	\$ 129.65
Circulation Pump	7.5	24.0	\$ 5,834.16
Heating Gas			\$ 2,500.00
			<u>\$ 21,687.90</u>

Replacement Parts \$ 2,500.00

**Annual O&M For Option 1 Items \$30,119.15**

**Option 2 - No Primary Clarification - Aerobic Digestion**

Staffing	Rate	Hrs/Day	Cost per Year
Operations Staff - Supervisor	\$75	0.1	\$2,737.50
Operations Staff - Supervisor	\$35	0.15	\$1,916.25
			<u>\$4,653.75</u>

Electrical & Utilities	HP or KW	Hrs/Day	Annual Cost
Digester Mixer/Aeration	40.0	16.0	\$ 20,743.68
Sludge Transfer Pumps	4.0	1.0	\$ 129.65
			<u>\$ 20,873.33</u>

**Annual O&M For Option 2 Items \$25,527.08**

**Notes**

Electrical Cost at \$0.12/KWH  
 Gas cost estimated based on current usage and estimated increase in efficiency



123 W. Main St., Suite 200

Gaylord, MI 49735

O: 989.732.8131

**PROJECT**      Tawas Utilities Authority WWTP

**PROJECT NO.**      20-0112

**BY:**      MPF

**ITEM**      Rehabilitate Primary Clarifiers & Sludge Pumps

**DATE:**      3/20/21

DIVISION	DESCRIPTION	QUANT.	UNIT	UNIT AMOUNT	TOTAL AMOUNT
1	General Conditions (8%)	1	Ls	\$16,585	\$16,585
	Conceptual Design Contingencies	1	Ls	\$20,731	\$20,731
2	Concrete Repair	1	Ls	\$18,000	\$18,000
	Equipment Removals	2	Ls	\$4,400	\$8,800
	Remove Existing Pumps	1	Ls	\$1,000	\$1,000
	Remove 3-Way Valves and Piping	1	Ls	\$3,200	\$3,200
6	Railings and Grating	1	Ls	\$2,500	\$2,500
9	Coatings	1	Ls	\$15,000	\$15,000
40	Sludge Collectors	2	Ea	\$26,000	\$52,000
	Drive Gear for Collectors	2	Ea	\$14,300	\$28,600
	Worm Gear Skimmer	2	Ls	\$9,800	\$19,600
	Effluent Trough and Baffles	1	Ls	\$1,060	\$1,060
	Install New Rotary Lobe Pumps	2	Ls	\$17,500	\$35,000
	Install New Valves and Piping	1	Ls	\$1,500	\$1,500
	Equipment Installation 30%	1	Ls	\$21,048	\$21,048
	<b>Subtotal Construction</b>				<b>\$245,000</b>
	<b>Engineering, Planning, Contingencies</b>				<b>\$74,000</b>
	<b>Total Capital Cost</b>				<b>\$319,000</b>



123 W. Main St., Suite 200

Gaylord, MI 49735

O: 989.732.8131

**PROJECT** Tawas Utilities Authority WWTP

**PROJECT NO.** 20-0112

**BY:** MPF

**ITEM** Rehabilitate Anaerobic Digesters

**DATE:** 3/20/21

DIVISION	DESCRIPTION	QUANT.	UNIT	UNIT AMOUNT	TOTAL AMOUNT
	General Conditions	1	Ls	\$35,563	\$35,563
	Conceptual Design Contingencies	1	Ls	\$44,454	\$44,454
	Remove Existing Equipment	1	Ls	\$15,000	\$15,000
	Concrete Repair	1	Ls	\$16,500	\$16,500
	Concrete Coating	1	Ls	\$28,500	\$28,500
	Sediment Trap	1	Ea	\$11,287	\$11,287
	Flame Trap	1	Ls	\$7,650	\$7,650
	Pressure Regulator	1	Ea	\$7,100	\$7,100
	Replace Sludge Recirculation Pumps	2	Ea	\$17,500	\$35,000
	Yard Burner Relief Valve & Pressure Regulator	1	Ea	\$6,400	\$6,400
	Waste Gas Burner and Ignition System	1	Ls	\$46,141	\$46,141
	Gas Flow Meter	1	Ls	\$4,200	\$4,200
	Digester Pressure/Vacuum Relief System	2	Ls	\$32,212	\$64,424
	Replace Mixer	1	Ls	\$45,200	\$45,200
	Remove Existing Foam Insulation	2	Ls	\$9,850	\$19,700
	Rebuild Floating Cover Seal	1	Ls	\$20,000	\$20,000
	Replace Heat Exchanger	1	Ea	\$36,000	\$36,000
	Replace Boiler	1	Ea	\$37,200	\$37,200
	Digester Cladding	2	Ea	\$18,570	\$37,140
	Misc. Piping and Valves	1	Ls	\$7,100	\$7,100
	Equipment Installation	1	Ls	\$81,493	\$81,493
	<b>Construction Subtotal</b>				<b>\$606,052</b>
	<b>Engineering, Planning and Contingencies</b>				<b>\$182,000</b>
	<b>Total Capital Cost</b>				<b>\$789,000</b>



123 W. Main St., Suite 200

Gaylord, MI 49735

O: 989.732.8131

**PROJECT**      Tawas Utilities Authority WWTP

**PROJECT NO.**      20-0112

**BY:**      MPF

**ITEM**      Delete Primary Clarifiers

**DATE:**      3/20/21

DIVISION	DESCRIPTION	QUANT.	UNIT	UNIT AMOUNT	TOTAL AMOUNT
1	General Conditions (8%)	1	Ls	\$1,326	\$1,326
	Conceptual Design Contingencies	1	Ls	\$1,658	\$1,658
	Equipment Removals	2	Ls	\$4,400	\$8,800
	Remove Existing Pumps	1	Ls	\$1,000	\$1,000
	Remove 3-Way Valves and Piping	1	Ls	\$3,200	\$3,200
	Piping Modifications	1	Ls	\$3,575	\$3,575
	<b>Subtotal Construction</b>				<b>\$20,000</b>
	<b>Engineering, Planning, Contingencies</b>				<b>\$6,000</b>
	<b>Total Capital Cost</b>				<b>\$26,000</b>

Note: Digester tank demolition not included. Tank is proposed for renovation to house tertiary filtration. Costs for modification are included in the filter installation.





123 W. Main St., Suite 200  
 Gaylord, MI 49735  
 O: 989.732.8131

**PROJECT**      Tawas Utilities Authority WWTP

**ITEM**            Convert Digesters to Aerobic

**PROJECT NO.**    20-0112

**BY:**                MPF

**DATE:**            3/5/21

DIVISION	DESCRIPTION	QUANT.	UNIT	UNIT AMOUNT	TOTAL AMOUNT
	General Conditions	1	Ls	\$30,580	\$30,580
	Conceptual Design Contingencies	1	Ls	\$38,225	\$38,225
	Remove Existing Digester Equipment	1	Ls	\$15,000	\$15,000
	Remove Boiler and Heat Exchanger	1	Ls	\$7,500	\$7,500
	Remove Existing Foam Insulation	2	Ls	\$3,400	\$6,800
	Remove Existing Digester Cover	1	Ls	\$6,500	\$6,500
	AI Dome Cover	1	Ls	\$35,000	\$35,000
	Misc. Piping and Valves	1	Ls	\$25,000	\$25,000
	Aeration and Mixing System	2	Ea	\$59,500	\$119,000
	Air Compressor for Mixing System	1	Ea	\$18,000	\$18,000
	Sludge Transfer Pumps	2	Ea	\$14,000	\$28,000
	Odor Control Bio Filter	1	Ea	\$29,500	\$29,500
	Fan and Duct to Odor Control	1	Ls	\$12,000	\$12,000
	Equipment Installation	1	Ls	79,950.00	\$79,950
	<b>Construction Subtotal</b>				<b>\$451,100</b>
	<b>Engineering, Planning and Contingencies</b>				<b>\$136,000</b>
	<b>Total Capital Cost</b>				<b>\$588,000</b>



123 W. Main St., Suite 200

Gaylord, MI 49735

O: 989.732.8131

PROJECT Tawas Utilities Authority WWTP

PROJECT NO. 20-0112

BY: MPF

ITEM Headworks Screening Improvements

DATE: 3/5/21

DIVISION	DESCRIPTION	QUANT.	UNIT	UNIT AMOUNT	TOTAL AMOUNT
<b><i>Raw Sewage Screening Improvements</i></b>					
1	General Conditions (8%)	1	Ls	\$61,154	\$61,154
	Conceptual Design Contingencies	1	Ls	\$76,442	\$76,442
2	Concrete Demolition	5	Cy	\$318	\$1,590
	Demolition of Existing Screen	1	Ls	\$1,500	\$1,500
3	Channel Modifications	5	Cy	\$1,060	\$5,300
26	Process Electrical Distribution	1	Ls	\$10,600	\$10,600
31	Channel Bulkheads	2	Ea	\$1,060	\$2,120
40	Aluminum Slide Gate	2	Ea	\$15,900	\$31,800
46	In Channel Sewage Grinder	1	Ls	\$62,500	\$62,500
	Automatic Bar Screen	1	Ls	\$190,000	\$190,000
	Building Addition for Screen	800	Sft	\$150	\$120,000
	Screen Equipment Installation	1	Ls	\$26,500	\$26,500
	Washer Compactor Equipment	1	Ls	\$127,200	\$127,200
	Compactor Installation	1	Ls	\$10,600	\$10,600
	Screening Chute	1	Ls	\$3,180	\$3,180
	Equipment Installation	1	Ls	\$171,534	\$171,534
	<b>Subtotal Construction</b>				<b>\$903,000</b>
	<b>Engineering, Planning, Contingencies</b>				<b>\$271,000</b>
	<b>Total Capital Cost</b>				<b>\$1,174,000</b>



123 W. Main St., Suite 200

Gaylord, MI 49735

O: 989.732.8131

PROJECT Tawas Utilities Authority WWTP PROJECT NO. 20-0112  
 BY: MPF  
 ITEM Grit System Odor Control DATE: 3/5/21

DIVISION	DESCRIPTION	QUANT.	UNIT	UNIT AMOUNT	TOTAL AMOUNT
1	General Conditions (8%)	1	Ls	\$37,670	\$37,670
	Conceptual Design Contingencies	1	Ls	\$47,088	\$47,088
	Equipment Removal	1	Ls	\$5,300	\$5,300
	Miscellaneous Demolition	1	Ls	\$10,600	\$10,600
	Grit Channel and Misc. Concrete	20	Cy	\$1,060	\$21,200
6	FRP Grating	80	Sf	\$159	\$12,720
	FRP Handrail	70	Lf	\$106	\$7,420
	FRP Tank Covers	400	Sft	\$82	\$32,800
40	Aluminum Slide Gates	6	Ea	\$15,900	\$95,400
	Process Instrumentation	1	Ls	\$15,900	\$15,900
	Odor Control System	1	Ls	\$200,000	\$200,000
	Equipment Installation	1	Ls	\$69,540	\$69,540
	<b>Subtotal Construction</b>				<b>\$556,000</b>
	<b>Engineering, Planning, Contingencies</b>				<b>\$167,000</b>
	<b>Total Capital Cost</b>				<b>\$723,000</b>



123 W. Main St., Suite 200  
 Gaylord, MI 49735  
 O: 989.732.8131

**PROJECT**      Tawas Utilities Authority WWTP      **PROJECT NO.**      20-0112  
**BY:**      MPF  
**ITEM**      Rehabilitate Oxidation Ditches      **DATE:**      3/5/21

DIVISION	DESCRIPTION	QUANT.	UNIT	UNIT AMOUNT	TOTAL AMOUNT
<b><i>Vortex Grit Installation</i></b>					
	General Conditions (8%)	1	Ls	\$18,568	\$18,568
1	Conceptual Design Contingencies	1	Ls	\$23,210	\$23,210
	Concrete Demolition	2	Ea	\$4,500	\$9,000
2	Repair Concrete	2	Ea	\$12,000	\$24,000
	Clean Tanks	2	Ea	\$15,000	\$30,000
	Railing on Tanks	500	Lf	\$24	\$12,000
	Tank Coating	2	Ea	\$39,500	\$79,000
9	Electrical Modifications	1	Ls	\$15,000	\$15,000
26	Remove Existing Equipment	2	Ea	\$2,800	\$5,600
	Replace Aerators	4	Ea	\$12,500	\$50,000
40	Equipment Installation	2	Ea	\$3,750	\$7,500
	<b>Subtotal Construction</b>				<b>\$274,000</b>
	<b>Engineering, Planning, Contingencies</b>				<b>\$83,000</b>
	<b>Total Capital Cost</b>				<b>\$357,000</b>



123 W. Main St., Suite 200  
 Gaylord, MI 49735  
 O: 989.732.8131

**PROJECT**      Tawas Utilities Authority WWTP

**PROJECT NO.**      20-0112

**BY:**      MPF

**ITEM**      Secondary Clarifier Rehabilitation

**DATE:**      3/5/21

DIVISION	DESCRIPTION	QUANT.	UNIT	UNIT AMOUNT	TOTAL AMOUNT
1	General Conditions (8%)	1	Ls	\$22,288	\$22,288
	Conceptual Design Contingencies	1	Ls	\$27,860	\$27,860
	Equipment Removal	1	Ls	\$3,500.00	\$3,500
	Blast Clean Steel	2	Ea	\$11,000.00	\$22,000
	Clean Tanks	2	Ea	\$15,000	\$30,000
9	Tank Coating	2	Ea	\$12,000	\$24,000
9	Mechanism Coating	2	Ea	\$29,000	\$58,000
26	Electrical Modifications	1	Ls	\$15,000	\$15,000
40	Drive Replacements	2	Ea	\$48,500	\$97,000
	Equipment Installation	1	Ls	\$29,100	\$29,100
	<b>Subtotal Construction</b>				<b>\$329,000</b>
	<b>Engineering, Planning, Contingencies</b>				<b>\$99,000</b>
	<b>Total Capital Cost</b>				<b>\$428,000</b>



123 W. Main St., Suite 200  
 Gaylord, MI 49735  
 O: 989.732.8131

**PROJECT**      Tawas Utilities Authority WWTP

**PROJECT NO.**      20-0112

**BY:**      MPF

**ITEM**      RAS and WAS Sludge Piping

**DATE:**      3/5/21

DIVISION	DESCRIPTION	QUANT.	UNIT	UNIT AMOUNT	TOTAL AMOUNT
	General Conditions	1	Ls	\$12,987	\$12,987
	Conceptual Design Contingencies	1	Ls	\$16,234	\$16,234
	Remove Existing RAS Pumps	1	LS	\$7,500	\$7,500
	RAS Pump	2	Ea	\$17,200	\$34,400
	WAS Pump	2	Ea	\$13,600	\$27,200
	Piping Modifications	1	Ls	\$35,000	\$35,000
	RAS Flow Meters	2	Ea	\$13,000	\$26,000
	WAS Flow Meters	2	Ea	\$7,000	\$14,000
	Installation Labor 30%	1	Ea	\$25,740	\$25,740
	<b>Subtotal Construction</b>				<b>\$200,000</b>
	<b>Engineering, Planning, Contingencies</b>				<b>\$60,000</b>
	<b>Total Capital Cost</b>				<b>\$260,000</b>

Note:

1. Above assumes air supply from aeration blowers. Conversion to local grit blowers is recommended but will be done at a later time.
2. Engineering may only be needed for design of grit slurry pumping system. Above engineering cost assumes engineering for a complete bid-construct project.



123 W. Main St., Suite 200  
 Gaylord, MI 49735  
 O: 989.732.8131

**PROJECT** Tawas Utilities Authority WWTP

**PROJECT NO.** 20-0112

**BY:** MPF

**ITEM** Tertiary Filtration

**DATE:** 3/5/21

DIVISION	DESCRIPTION	QUANT.	UNIT	UNIT AMOUNT	TOTAL AMOUNT
1	General Conditions	1	Ls	\$51,186	\$51,186
	Conceptual Design Contingency	1	Ls	\$15,900	\$15,900
	Partial Demolition of Primary Clarifiers	1	Ls	\$3,180	\$3,180
	Concrete Work	25	Cyd	\$750	\$18,750
	Filter Building Enclosure	600	Sft	\$150	\$90,000
	Cloth Disk Filter Complete	2	Ea	\$350,000	\$700,000
	Piping Modification	1	Ls	\$9,500	\$9,500
	Slide Gates	4	Ea	\$2,500	\$10,000
3	Electrical and Control	1	Ls	\$45,000	\$45,000
	Equipment Installation	1	Ls	\$212,850	\$212,850
	<b>Construction Subtotal</b>				<b>\$1,157,000</b>
	<b>Engineering, Planning and Contingencies</b>				<b>\$348,000</b>
	<b>Total Capital Cost</b>				<b>\$1,505,000</b>



123 W. Main St., Suite 200  
 Gaylord, MI 49735  
 O: 989.732.8131

PROJECT Tawas Utilities Authority WWTP

PROJECT NO. 20-0112

BY: MPF

ITEM UV Disinfection

DATE: 3/5/21

DIVISION	DESCRIPTION	QUANT.	UNIT	UNIT AMOUNT	TOTAL AMOUNT
	General Conditions	1	Ls	\$52,472	\$52,472
	Conceptual Design Contingencies	1	Ls	\$65,590	\$65,590
	Primary Clarifier Modifications	1	Ls	\$65,000	\$65,000
	Cast in Place Concrete	30	Cyd	\$750	\$22,500
	Roof with Support System	720	Sft	\$95	\$68,400
	UV Disinfection	1	Ls	\$310,000	\$310,000
	Effluent Wiers	1	Ls	\$45,000	\$45,000
	Electrical Supply	1	Ls	\$38,500	\$38,500
	Equipment Installation	1	Ls	\$106,500	\$106,500
	<b>Construction Subtotal</b>				<b>\$774,000</b>
	<b>Engineering, Planning and Contingencies</b>				<b>\$233,000</b>
	<b>Total Capital Cost</b>				<b>\$1,007,000</b>





123 W. Main St., Suite 200  
 Gaylord, MI 49735  
 O: 989.732.8131

PROJECT Tawas Utilities Authority WWTP

PROJECT NO. 20-0112

BY: MPF

ITEM Effluent Metering

DATE: 3/21/21

DIVISION	DESCRIPTION	QUANT.	UNIT	UNIT AMOUNT	TOTAL AMOUNT
	General Conditions	1	Ls	\$1,590	\$1,590
	Conceptual Design Contingencies	1	Ls	\$10,600	\$10,600
	Structure Modifications	1	Ls	\$3,180	\$3,180
	Parshal Flume insert	1	Ea	\$3,600	\$3,600
	Level Sensor	2	Ea	\$5,300	\$10,600
	Electrical	1	Ls	\$2,500	\$2,500
	<b>Construction Subtotal</b>				<b>\$33,000</b>
	<b>Engineering, Planning and Contingencies</b>				<b>\$10,000</b>
	<b>Total Capital Cost</b>				<b>\$43,000</b>



123 W. Main St., Suite 200  
 Gaylord, MI 49735  
 O: 989.732.8131

PROJECT Tawas Utilities Authority WWTP

PROJECT NO. 20-0112

BY: MPF

ITEM Sludge Storage and Mixing

DATE: 3/5/21

DIVISION	DESCRIPTION	QUANT.	UNIT	UNIT AMOUNT	TOTAL AMOUNT
	General Conditions	1	Ls	\$115,706	\$115,706
	Conceptual Design Contingencies	1	Ls	\$10,600	\$10,600
	Storage Tank Base, Cast in Place	270	Cyd	\$450	\$121,500
	Steel Tank with Dome Cover	1	Ea	\$700,000	\$700,000
	Piping and Valves	1	Ls	\$65,500	\$65,500
	Automate Existing Decant Valves	4	Ea	\$4,500	\$18,000
	Sludge Mixing System with Chopper Pump	1	Ea	\$465,000	\$465,000
	Renovate Truck Fill Station	1	Ls	\$8,500	\$8,500
	Electrical	1	Ls	\$49,000	\$49,000
	Instrumentation and SCADA	1	Ls	\$8,480	\$8,480
	Equipment Installation	1	Ls	\$144,900	\$144,900
	<b>Construction Subtotal</b>				<b>\$1,708,000</b>
	<b>Engineering, Planning and Contingencies</b>				<b>\$513,000</b>
	<b>Total Capital Cost</b>				<b>\$2,221,000</b>



123 W. Main St., Suite 200  
 Gaylord, MI 49735  
 O: 989.732.8131

PROJECT Tawas Utilities Authority WWTP

PROJECT NO. 20-0112

BY: MPF

ITEM Building Improvements

DATE: 3/5/21

DIVISION	DESCRIPTION	QUANT.	UNIT	UNIT AMOUNT	TOTAL AMOUNT
	General Conditions	1	Ls	\$8,227	\$8,227
	Conceptual Design Contingencies	1	Ls	\$10,284	\$10,284
	<u>Main Building</u>				
	Repair Conduit Piping/Ground Water Leaks	1		\$5,600	\$5,600
	Replace Roof- Fiberglass Shingles	6,284	Ls	\$8	\$50,272
			Sf		
	<u>Grit Building</u>				
	Paint Basement	1,100	Sf	\$15	\$16,500
	Lead Abatement	1,100	Sf	\$15	\$16,500
	Replace Roof- Fiberglass Shingles				
	<u>Return Activated Sludge Building</u>				
	Replace Roof- Fiberglass Shingles	692	Sf	\$8	\$5,536
	<u>Chlorination Building</u>				
	Replace Roof- Fiberglass Shingles	1,054	Sf	\$8	\$8,432
	<b>Construction Subtotal</b>		Ls		<b>\$121,400</b>
	<b>Engineering, Planning and Contingencies</b>				<b>\$37,000</b>
	<b>Total Capital Cost</b>				<b>\$159,000</b>



123 W. Main St., Suite 200  
 Gaylord, MI 49735  
 O: 989.732.8131

PROJECT Tawas Utilities Authority WWTP

PROJECT NO. 20-0112

BY: MPF

ITEM Main Building HVAC System Improvements

DATE: 3/5/21

DIVISION	DESCRIPTION	QUANT.	UNIT	UNIT AMOUNT	TOTAL AMOUNT
	General Conditions	1	Ls	\$6,880	\$6,880
	Conceptual Design Contingencies	1	Ls	\$8,600	\$8,600
	Geothermal Heating Cooling System 91)	1	Ls	\$45,000	\$45,000
	Replacement Hydronic Piping	1	Ls	\$18,500	\$18,500
	Replacement Unit Heater-Chillers	10	Ls	\$2,250	\$22,500
	<b>Construction Subtotal</b>				<b>\$102,000</b>
	<b>Engineering, Planning and Contingencies</b>				<b>\$31,000</b>
	<b>Total Capital Cost</b>				<b>\$133,000</b>



123 W. Main St., Suite 200  
 Gaylord, MI 49735  
 O: 989.732.8131

PROJECT Tawas Utilities Authority WWTP

PROJECT NO. 20-0112

BY: MPF

ITEM Electrical Improvements

DATE: 3/5/21

DIVISION	DESCRIPTION	QUANT.	UNIT	UNIT AMOUNT	TOTAL AMOUNT
	General Conditions	1	Ls	\$46,600	\$46,600
	Conceptual Design Contingencies	1	Ls	\$58,250	\$58,250
	Main MCC Modifications	1	Ls	\$145,000	\$145,000
	Replacement Stand-by Generator	1	Ls	\$140,000	\$140,000
	Generator Auto Transfer Switch	1	Ls	\$68,500	\$68,500
	Electrical to Filter-UV Building	1	Ls	\$15,000	\$15,000
	Electrical Service to Sludge Mixing	1	Ls	\$68,500	\$68,500
	Electrical Service to Aerobic Digesters	1	Ls	\$22,000	\$22,000
	RAS Bldg, MCC Upgrade	1	Ls	\$45,000	\$45,000
	Abandonment Electrical-Primary Clarifiers	1	Ls	\$3,500	\$3,500
	Misc. Electrical Upgrades	1	Ls	\$75,000	\$75,000
	<b>Construction Subtotal</b>				<b>\$688,000</b>
	<b>Engineering, Planning and Contingencies</b>				<b>\$207,000</b>
	<b>Total Capital Cost</b>				<b>\$895,000</b>



123 W. Main St., Suite 200  
 Gaylord, MI 49735  
 O: 989.732.8131

PROJECT Tawas Utilities Authority WWTP

PROJECT NO. 20-0112

BY: MPF

ITEM SCADA System Upgrade

DATE: 3/5/21

DIVISION	DESCRIPTION	QUANT.	UNIT	UNIT AMOUNT	TOTAL AMOUNT
	General Conditions	1	Ls	\$26,038	\$26,038
	Conceptual Design Contingencies	1	Ls	\$32,548	\$32,548
	MCP (Admin) Upgrade, PLC, I/O	1	Ls	\$145,000	\$145,000
	RAS System CP	1	Ls	\$37,500	\$37,500
	Filtration UV CP	1	Ls	\$12,500	\$12,500
	Signal Devices, Meter, Level Tans. , Etc	1	Ls	\$65,000	\$65,000
	SCADA Software	1	Ls	\$8,480	\$8,480
	SCADA Programming	1	Ls	\$32,000	\$32,000
	SCADA and Operating Hardware	1	Ls	\$25,000	<u>\$25,000</u>
	<b>Construction Subtotal</b>				<b>\$385,000</b>
	<b>Engineering, Planning and Contingencies</b>				<b>\$116,000</b>
	<b>Total Capital Cost</b>				<b>\$501,000</b>



123 W. Main St., Suite 200  
 Gaylord, MI 49735  
 O: 989.732.8131

PROJECT Tawas Utilities Authority WWTP

PROJECT NO. 20-0112

BY: MPF

ITEM Structural, Safety and Other Improvements

DATE: 3/5/21

DIVISION	DESCRIPTION	QUANT.	UNIT	UNIT AMOUNT	TOTAL AMOUNT
	General Conditions	1	Ls	\$15,800	\$15,800
	Conceptual Design Contingencies	1	Ls	\$19,750	\$19,750
	Replace Ferric Feed Piping to Secondary Clarifiers	1	Ls	\$5,000	\$5,000
	Replace Ferric Chloride Pumps	1	Ls	\$19,000	\$19,000
	Replace Automatic Samplers	1	Ls	\$68,000	\$68,000
	Replace Process Valves and Yard Piping	1	Ls	\$79,500	\$79,500
	Plant Drain Line Upgrades	1	Ls	\$12,500	\$12,500
	Seeding, Landscaping and Restoration	1	Ls	\$13,500	\$13,500
	Code Compliance Upgrades	1	Ls	\$45,000	\$45,000
	<b>Construction Subtotal</b>				<b>\$279,000</b>
	<b>Engineering, Planning and Contingencies</b>				<b>\$84,000</b>
	<b>Total Capital Cost</b>				<b>\$363,000</b>

## **APPENDIX E**

### **PUBLIC PARTICIPATION**

- Affidavit of Publication of Public Hearing Notice**
- Public Hearing Transcript**
- Resolution of Adoption**



STATE OF MICHIGAN }ss

\_\_\_\_\_ County of Iosco

# NOTICE OF PROJECT PLAN PUBLIC HEARING

## Tawas Utilities Authority Wastewater Treatment Plant Improvements

City of East Tawas, City of Tawas City,  
Baldwin Township, Michigan

The Tawas Utilities Authority (TUA) will hold a public hearing on the proposed Wastewater Treatment Plant (WWTP) Improvement project for the purpose of receiving comments from interested persons.

The hearing will be held via Zoom at 9 a.m. on Thursday, May 27, 2021. You can participate in the meeting via the following link or by telephone:

**Join Zoom Meeting: <https://us02web.zoom.us/j/13126266799>**  
**One tap mobile**

**+13126266799,,83467057481#,,,,\*971398# US (Chicago)**

**+19292056099,,83467057481#,,,,\*971398# US (New York)**

**Meeting ID: 834 6705 7481**

Find your local number: <https://us02web.zoom.us/j/13126266799>

The purpose of the proposed project is to construct WWTP improvements to replace outdated equipment and construct new components to improve treatment reliability and efficiency. The improvements will include new tankage, process equipment, piping and electrical work.

Impacts of the proposed project include temporary noise and dust associated with construction projects. The improvements should not cause measurable long term detrimental environmental impacts.

Preliminary estimated cost to users for the proposed project may result in an increase in user rates of approximately (up to) \$16 to \$22 per month per average residential user. This does not include the potential for a reduced project, principal forgiveness or other funding sources which may reduce these rate impacts.

Copies of the plan detailing the proposed project are available for inspection at the following location(s): City of Tawas City and East Tawas Municipal offices. Documents are also available on both municipality's websites. The wastewater treatment plant will also be holding an "Open House" for residents to tour the plant on Thursday, May 20, 2021 between 10:00 a.m. and noon.

Written comments received before the hearing record is closed on May 27, 2021 will receive responses in the final project plan. Written comments should be sent to Julie Potts, City of East Tawas, 760 Newman Street, East Tawas, MI 48730.

**John Morris**

being duly sworn, deposes and says that he is the co-editor of the IOSCO COUNTY NEWS-HERALD, a newspaper published and circulating in the County of Iosco, in said State, that the annexed printed notice has been published on the following date, to wit:

April 28, 2021

  
\_\_\_\_\_  
John Morris, Co-Editor

Subscribed and sworn to before me this  
28th day of April A.D. 2021.

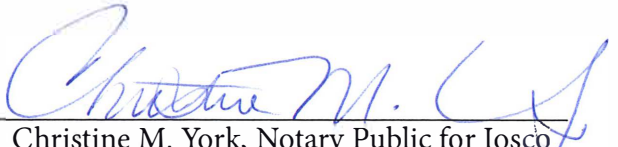
  
\_\_\_\_\_  
Christine M. York, Notary Public for Iosco  
County, Acting in Iosco County, Michigan  
My Commission expires March 6, 2023

**LOCAL NEWS**

**Michigan Agri-Business Association says rural infrastructure is in crisis**

LANSING – The Michigan Agri-Business Association (MABA) has pointed to new facts released by the federal government as the latest showcase of Michigan's failing rural infrastructure – which MABA says is a crisis that threatens one of our state's leading economic drivers and harms quality of life for rural families.

"The information released today by the White House further illustrates the historic infrastructure crisis Michigan's rural businesses and families are dealing with every day," MABA President Chuck

Lippstreu stated, on April 12. "We need to fix the roads. We need to repair crumbling bridges and rail lines that can't handle the crops we produce. And we need to deliver reliable broadband that links rural Michigan to the world."

A Michigan fact sheet released by the White House, in support of the Biden Administration's American Jobs Plan proposal, is available at <https://www.whitehouse.gov/wp-content/uploads/2021/04/AJP-State-Fact-Sheet-MI.pdf>.

Among the issues detailed in the data, the new fact sheet notes the following:

- There are more than 1,200 Michigan bridges and 7,300 miles of highway in poor condition.

- According to MABA, many of these are in rural areas. Bridge and highway problems in rural Michigan create substantial logistics problems for agri-businesses, especially those in the grain and feed sector.

- By one definition, nearly one in 10 Michiganders live in areas where there is no broadband infrastructure which provides minimally acceptable speeds, and more than half live in areas with only one internet provider.

Access to reliable, high-speed rural broadband is a critical element for the use of advanced new technology in agriculture, and to facilitate commerce.

- Investment in resilient Michigan infrastructure has fallen behind substantially, earning Michigan a dismal D+ on an infrastructure scorecard.

Lippstreu noted that, in addition to road and bridge problems, many rail lines serving agri-businesses are in dire need of repair and upgrade. New rail investment is needed to expand agricultural

freight handling capacity in Michigan and enable the agricultural economy to be successful.

"Infrastructure isn't just an issue for our cities. The fact is we're badly behind in delivering infrastructure solutions to rural America and rural Michigan," Lippstreu said. "We need historic investment in rural roads, bridges, rail and broadband, and Michigan's agribusinesses will continue to work with our state and federal leaders to highlight this critical situation."

**Thousands eligible for expungement, with Michigan Works! assistance now available**

EAST TAWAS – The Clean Slate Program became law on April 11, but automatic expungements for eligible citizens will not begin for a few more years.

The Clean Slate Pilot Program is a \$4 million investment launched to offer stop-gap expungement services until automatic expungements go into effect, which is expected to happen in 2023. Michigan Works! agencies throughout Michigan will offer localized efforts to help those interested in applying for the program.

To serve the Northeast Michigan region, Michigan Works! Northeast Consortium welcomes Jason Secord to their team as their new Expungement Navigator. Jason will help applicants through the entire expungement process, working with them to determine eligibility, navigate the application process, and assist with document submission. Michigan Works! can also help applicants pay their legal and attorney fees for the expunge-

ment.

Setting aside a conviction, sometimes called expungement of criminal records, will remove a specific conviction from a public criminal record. If returning citizens get an order setting aside their conviction, they can legally state on any job or school application that they have never been convicted of or arrested for that crime. They will also be able to state that they have not been convicted of that crime on applications for public benefits, housing or employment.

With the new Clean Slate Program, you may be eligible to remove up to three felonies and unlimited misdemeanors from your record, including most traffic offenses and misdemeanor marijuana convictions. A minimum of a 5 year clean record is required, and some convictions, including most violent crimes, criminal sexual conduct, and alcohol-related driving offenses, will not be eligible

for expungement.

"Before this legislation, just under 7 percent of eligible individuals pursued an expungement," said Shamar Herron, Executive Director, Michigan Works! Southeast. "We know how important equitable access to expungements are for job seekers. According to a University of Michigan Study, after having a record expunged, job seekers obtained employment at an increase of 11 percent and their income rose by 25 percent in two years. Michigan Works! Agencies and the Clean Slate Pilot program will help job seekers overcome many barriers and guide them on a path to success, while providing support to area businesses by increasing the number of available workers, adding to the talent pool."

If you're interested in setting aside any of your past convictions, contact Jason Secord for more information at 989-306-7288 or email [secordj@necnetworks.org](mailto:secordj@necnetworks.org).



**Notice to Iosco County Residents**

Iosco County along with the Iosco County Sheriff's Office have applied to the United States Department of Agriculture (USDA) for a grant to help us purchase a new fully outfitted patrol car.

The Iosco County Board of Commissioners will hold a public hearing on May 19, 2021 in the Board of Commissioners room, 422 W. Lake St., Tawas City, MI beginning at 10 a.m. as required by law.

For more information please contact the Iosco County Board of Commissioners during regular business hours, Monday through Friday 8:30 a.m. to 4:30 p.m.



Real estate transactions recorded by the Iosco County Register of Deeds from April 12 through April 16 are as follows:

**Ausable Twp.**

Maureen Coon to John Eloff and Francesca Nesi-Eloff, 4014 N. US-23

**Baldwin Twp.**

David Grissom to Ryan and Allyson Hathaway, 462 Huron Hills Dr.

Joseph Lubaway, Judith Spooner, Marcia, Michael, and Brett Lubaway, Stacey LaFleur and William Lubaway to Craig and Rene Henriksen, Huron Shores Subdivision, Lot 40; 1st Add to Huron Shores Subdivision, Lot 8, Blk E; Lot 1, Blk F.

Brett Lubaway, Stacey LaFleur and William Lubaway to Craig and Rene Henriksen, 1st Add to Huron Shores Subdivision, Lot 41. Kushuba Trust to Suzanne Kushuba, 675 Lakeview Dr., #11. Bradley Lewis Estate to Carol Lewis, 1173 Cranberry Pike.

**East Tawas**

John Loeffler Trust to Cathleen Archambeau, 401 E. Westover St. June MacMurray Trust to Kelly Seitter, 218 W. Tawas Lake Rd.

**Grant Twp.**

Harvey King to Scott Hicks, 3900 Saginaw St.

Jerry Bancroft to Wesley and Patricia Ross, 4105 Old State Rd. Patricia Johnson Trust to Valerie Bayer, 1984 Sunset Tr.

Valerie Bayer to Terry and Marla Henika, 1984 Sunset Tr.

**Oscoda Twp.**

Donald and Doreen Skarjune

to Mark and Christine Monette, Lake Huron Sand Beach Subdivision #4, Lot 442.

Roy Mickens to Charter Township of Oscoda, 227 E. River Rd. Dennis Dunn to Kim Bumsoo, 810A Colorado St.

Michael Ryman to Edward and Mary Meltz, Interlake Park Subdivision, Lot 68.

Devin Ryman to Edward and Mary Meltz, Interlake Park Subdivision, Lot 72.

John and Emily Seal to John and Shondra Briley, 4770 Arbutus Tr.

James Elsarelli to Marilyn Elsarelli, Lakewood Shores Subdivision No. 2, Lot 90.

Mark Elsarelli to Marilyn Elsarelli, Lakewood Shores Subdivision No. 2, Lot 90.

Thomas Elsarelli to Marilyn Elsarelli, Lakewood Shores Subdivision No. 2, Lot 90. Robert and Dana Lerchenfeld to Stephen and Antoinette Hurley, Lakewood Shores Subdivision No. 10, Lot 863.

Paul and Isabella Flora and Grace Hansen to Paul and Isabella Flora. Timothy and Erin Kellstrom, Lakewood Shores Subdivision No. 11, Lot 1001.

**Plainfield Twp.**

Joshua Morris to Ryan Strauss, Part of NE-NE, T23N-R5E, Section 7.

Williams Trust to Denise Clancy Trust, 7758 Hillsdale Dr.

**Reno Twp.**

Paul Aylsworth Trust to Lake City Investment & Tech LLC, Part of SE-NE, T22N-R5E, Section 23.

Peter Barbier Trust to Daniel and Kelly Frank, Part of S-SW-SE, T22N-R5E, Section 33; Part of SE-SW, T22N-R5E, Section 33.

**Sherman Twp.**

Alan Sanders Estate to Raquel Hernandez Estate, 3455 S. National City Rd.

**Tawas City**

Joshua Wilson to William Kendall, Map of Tawas City, Lots 10-11.

**Tawas Twp.**

John and Kimberly Grove to Grove Trust, 1797 Laidlaw Rd.

**LEGAL & PUBLIC NOTICES**

**NOTICE TO CREDITORS**

Decedent's Estate State of Michigan, File No: 21-004309-DE Probate Court County of Iosco Estate of Richard Clifford Lilly Sr., deceased, date of birth July 9, 1949.

NOTICE TO CREDITORS: The decedent, Richard Clifford Lilly Sr., died October 4, 2020.

Creditors of the decedent are notified that all claims against the estate will be forever barred unless presented to Kenneth McBride, personal representative, or to both the probate court at 422 W. Lake Street, P.O. Box 609, Tawas City, MI 48764-0609 and the personal representative within 4 months after the date of publication of this notice.

Date: April 19, 2021 Kenneth McBride 3635 Los Angeles Ave. Warren, MI 48091 586-365-8493

James A. Bacarella P46198 1228 E. US-23 East Tawas, MI 48730 989-362-1364

**NOTICE OF PROJECT PLAN PUBLIC HEARING**

**Tawas Utilities Authority Wastewater Treatment Plant Improvements**  
City of East Tawas, City of Tawas City, Baldwin Township, Michigan

The Tawas Utilities Authority (TUA) will hold a public hearing on the proposed Wastewater Treatment Plant (WWTP) improvement project for the purpose of receiving comments from interested persons.

The hearing will be held via Zoom at 9 a.m. on Thursday, May 27, 2021. You can participate in the meeting via the following link or by telephone:

Join Zoom Meeting: <https://us02web.zoom.us/j>

One tap mobile +13126266799, 83467057481#,\*,\*,\*971398# US (Chicago)

+19292056099, 83467057481#,\*,\*,\*971398# US (New York)

Meeting ID: 834 6705 7481

Find your local number: <https://us02web.zoom.us/j/kd9JdrHW>

The purpose of the proposed project is to construct WWTP improvements to replace outdated equipment and construct new components to improve treatment reliability and efficiency. The improvements will include new tankage, process equipment, piping and electrical work.

Impacts of the proposed project include temporary noise and dust associated with construction projects. The improvements should not cause measurable long term detrimental environmental impacts.

Preliminary estimated cost to users for the proposed project may result in an increase in user rates of approximately (up to) \$16 to \$22 per month per average residential user. This does not include the potential for a reduced project, principal forgiveness or other funding sources which may reduce these rate impacts.

Copies of the plan detailing the proposed project are available for inspection at the following location(s): City of Tawas City and East Tawas Municipal offices. Documents are also available on both municipality's websites. The wastewater treatment plant will also be holding an "Open House" for residents to tour the plant on Thursday, May 20, 2021 between 10:00 a.m. and noon.

Written comments received before the hearing record is closed on May 27, 2021 will receive responses in the final project plan. Written comments should be sent to Julie Potts, City of East Tawas, 760 Newman Street, East Tawas, MI 48730.

1  
2  
3  
4  
5  
6  
7  
8  
9  
10  
11  
12  
13  
14  
15  
16  
17  
18  
19  
20  
21  
22  
23  
24  
25

CITY OF EAST TAWAS, CITY OF TAWAS CITY,  
BALDWIN TOWNSHIP, MICHIGAN  
TAWAS UTILITIES AUTHORITY  
WASTEWATER TREATMENT PLANT IMPROVEMENTS

THURSDAY, MAY 27, 2021  
9:00 A.M.

A meeting before the Utilities  
Authority Commission, via in-person and Zoom  
technology.

BOARD MEMBERS PRESENT:  
Brent Barringer, Vice-Chair  
Mike Russo, Member (via Zoom)  
Brian McMurray, Member  
David Leslie, Member

CITY OFFICIALS PRESENT:  
Julie Potts, Secretary/Treasurer

PRESENTERS:  
Larry Fox, C2AE  
Mike Faeth, C2AE

MINUTES RECORDED BY:  
Quentina R. Snowden, (CSR-5519)  
Certified Shorthand Reporter & Notary Public

MEMBERS OF THE PUBLIC ADDRESSING THE BOARD:  
(None.)

1 East Tawas, Michigan  
2 Thursday, May 27, 2021  
3 9:00 a.m.

4 VICE-CHAIR BARRINGER: Then we'll call  
5 the meeting to order, Julie, at 9:00.

6 SECRETARY POTTS: Barringer?

7 VICE-CHAIR BARRINGER: Here.

8 SECRETARY POTTS: Leslie?

9 MEMBER LESLIE: Here.

10 SECRETARY POTTS: McMurray?

11 MEMBER McMURRAY: Here.

12 SECRETARY POTTS: And Russo?

13 MEMBER RUSSO: Here.

14 SECRETARY POTTS: Can you hear me,  
15 Mike? Okay.

16 VICE-CHAIR BARRINGER: We're all here.

17 MEMBER RUSSO: What was that, Julie?

18 SECRETARY POTTS: Calling for roll  
19 call. Are you here?

20 MEMBER RUSSO: Yeah, I'm here.

21 SECRETARY POTTS: Okay. I just wanted  
22 to make sure you could hear me.

23 VICE-CHAIR BARRINGER: Larry and Mike,  
24 can you guys hear us all right?

25 MR. FOX: Yeah, I can.

1 MR. FAETH: Yes, I'm here.

2 VICE-CHAIR BARRINGER: There's a delay  
3 here. We'll check the microphone. Okay. We have  
4 an agenda in front of us. I would ask that we  
5 consider adding C2AE's proposal that everyone  
6 received a little late, along with as item C and  
7 item D, an update from Inframark on current  
8 improvement needs.

9 MEMBER LESLIE: I'll support that  
10 motion.

11 MEMBER RUSSO: Can I ask a question?  
12 I know that Annge had sent an e-mail about the  
13 proposed budget. We're not going to approve that  
14 budget today. This is simply up for discussion,  
15 correct?

16 VICE-CHAIR BARRINGER: It's on the  
17 agenda. We don't need to approve it until the next  
18 meeting. Right, Julie?

19 SECRETARY POTTS: You don't have to,  
20 but if you want to approve it.

21 MEMBER RUSSO: Yeah, and that's what I  
22 was suggesting, was waiting.

23 SECRETARY POTTS: Okay.

24 VICE-CHAIR BARRINGER: Okay. So we  
25 have a motion to approve the agenda as amended. Do

1 we have a second?

2 MEMBER McMURRAY: Support.

3 VICE-CHAIR BARRINGER: Second by  
4 Brian. Can we have roll call on that, Julie?

5 SECRETARY POTTS: Yep. Barringer?

6 VICE-CHAIR BARRINGER: Yes.

7 SECRETARY POTTS: Leslie?

8 MEMBER LESLIE: Yes.

9 SECRETARY POTTS: McMurray?

10 MEMBER McMURRAY: Yes.

11 SECRETARY POTTS: And Russo?

12 MEMBER RUSSO: Yes.

13 VICE-CHAIR BARRINGER: Okay. First  
14 item on the agenda is the public hearing for the SRF  
15 project plan. So at this time, 9:03, we'll open up  
16 the public hearing.

17 Does anyone have any public comments  
18 on the project?

19 MR. FOX: Brent, this is Larry. Can I  
20 -- can I ask if there's any members of the -- well,  
21 first off, we have a court recorder or someone doing  
22 transcription?

23 SECRETARY POTTS: Yes.

24 VICE-CHAIR BARRINGER: Yes.

25 MR. FOX: Okay. Do we have any

1 members of the public that have attended -- either  
2 are attending either in-person or online?

3 SECRETARY POTTS: We just had one  
4 person pop up. Ed Nagy, and somebody at Tawas City  
5 Hall. I don't know who that is.

6 VICE-CHAIR BARRINGER: We'll let them  
7 sign in here.

8 MR. FOX: Okay. So, yes, we need to  
9 have names and addresses of any public that are  
10 attending; and then if I could, I'd like to share my  
11 screen. We have some things we have to cover.

12 SECRETARY POTTS: They haven't  
13 connected. We'll wait until they connect to the  
14 audio.

15 VICE-CHAIR BARRINGER: Okay. I'll  
16 give you rights to share your screen. Julie, I  
17 believe you're host, so could you do that? Right  
18 click on Larry and give him host rights.

19 SECRETARY POTTS: I don't know if  
20 that's allowed.

21 VICE-CHAIR BARRINGER: Let me sign  
22 out, see if that will work.

23 Larry, you should be all set.

24 MR. FOX: Okay. Everyone see that,  
25 correct?

1 VICE-CHAIR BARRINGER: Yes.

2 MR. FOX: Okay. Good. All right.

3 Well, so, if there are any members of the public  
4 here who are attending for the purposes of public  
5 hearing, we need to have your name and address  
6 stated for the record, please. No one attending  
7 from the public for the purposes of public hearing  
8 today?

9 VICE-CHAIR BARRINGER: Looks like we  
10 have -- Ed Nagy is on, and someone from Tawas City.  
11 Are you here to provide public comment?

12 SECRETARY POTTS: I don't know who is  
13 on from the City.

14 MR. NAGY: City Council member from  
15 Tawas City.

16 VICE-CHAIR BARRINGER: Ed, are you  
17 here to provide public comment?

18 MR. NAGY: No. A member of the City  
19 Council.

20 VICE-CHAIR BARRINGER: Okay. Thank  
21 you. Whoever is online with Tawas City, are you  
22 here to provide public comment? Are they still on,  
23 Julie?

24 SECRETARY POTTS: I don't see them on  
25 right now. I can't tell because I can't see with



1 the shared screen.

2 VICE-CHAIR BARRINGER: Looks like they  
3 dropped off.

4 MR. FOX: Well, the reason I bring  
5 this up is --

6 VICE-CHAIR BARRINGER: I was going to  
7 say --

8 MR. FOX: The reason I bring this up  
9 is the public hearing requirements for the State  
10 Revolving Fund. So first thing we have already  
11 talked about is public hearing transcript is  
12 required. And then for members of the public, we  
13 have to go through these particular items outlined  
14 A, B, C and D. But then in the event no one from  
15 the public attends the hearing, and a reporter would  
16 be considered a member of the public, the public  
17 hearing may be opened and closed without a formal  
18 presentation of the project plan. However, a  
19 transcript or recording must still be submitted with  
20 the final project plan.

21 So what I'm saying is, if no one is  
22 here wishes to receive a presentation on the project  
23 plan or is going to comment on the project plan, we  
24 don't have to spend the time to go through this  
25 review of the project plan and these elements. And

1 that appears to be what I'm hearing. We do have  
2 someone in the waiting room. Do I have to admit  
3 them now? It's a phone number.

4 SECRETARY POTTS: Yep, I see that.

5 VICE-CHAIR BARRINGER: Yeah, if you  
6 could do that, Larry.

7 MR. FOX: Okay. Good morning. Could  
8 the phone number 989-984-7192 please identify  
9 themselves.

10 CHAIR HORNING: This is Annge Horning.

11 MR. FOX: Oh, hi, Annge. You're not a  
12 member of the public either. This is Larry.

13 CHAIR HORNING: Hi, Larry.

14 MR. FOX: So, yes, we were just into  
15 the public hearing, but it doesn't appear that we  
16 have any members of the public participating either  
17 in-person or online with regards to the public  
18 hearing, and providing public input.

19 So what I was just telling the Board  
20 was that if there are no members, then you can just  
21 open and close the public hearing without a formal  
22 presentation. However, if any member of the Board  
23 would like a formal presentation, I would be happy  
24 to go through that.

25 VICE-CHAIR BARRINGER: Does anyone

1 want to have that?

2 MEMBER LESLIE: No.

3 MEMBER McMURRAY: No.

4 VICE-CHAIR BARRINGER: Anyone online?

5 MEMBER RUSSO: I'm fine with

6 proceeding without that. Not necessary.

7 MR. FOX: Okay. Brent, it's up to  
8 you.

9 VICE-CHAIR BARRINGER: Okay, yeah, I  
10 believe if there is no public present, and there's  
11 no sense of going through the project plan which  
12 everyone here has already been a part of, so with  
13 that, we can close the public hearing at 9:12 a.m.

14 MR. FOX: Okay. Brent, just a couple  
15 of items to add. So, Annge, has anyone provided any  
16 written public comment? Or I'm sorry, Julie?

17 SECRETARY POTTS: No.

18 MR. FOX: Okay. No public comment.  
19 Okay. So the things then that we need to do is  
20 obviously you'll talk about adoption of the plan in  
21 a minute. I will need the transcript, verbatim  
22 transcript of the public hearing opening and closing  
23 as soon as possible so we can get it in the plan.  
24 And then -- let's see, I think that's about it,  
25 other than you'll have your debate about whether to

1 adopt the project plan; and then if so, there will  
2 be a resolution that will be adopted and signed and  
3 then a couple of documents, Brent, that you'll need  
4 to provide for signature as well. So that's all I  
5 have.

6 VICE-CHAIR BARRINGER: Okay. All  
7 right. Thank you, Larry.

8 So that agenda item is considered  
9 complete. And is that adequate for your needs,  
10 Larry?

11 MR. FOX: Yes, it is.

12 VICE-CHAIR BARRINGER: Okay. Any  
13 other discussion on that agenda item before we move  
14 on?

15 MEMBER LESLIE: No.

16 VICE-CHAIR BARRINGER: The next item  
17 under business is Item A, SRF project plan  
18 resolution in the packet. There is a resolution to  
19 move forward with the project plan application. Any  
20 discussion or comments on this?

21 Do we have a motion to --

22 MEMBER LESLIE: Yes.

23 VICE-CHAIR BARRINGER: Motion by Dave.

24 MEMBER McMURRAY: Support.

25 VICE-CHAIR BARRINGER: Support by

1 Brian. Any discussion on that motion?

2 Can we have roll call, please, Julie.

3 SECRETARY POTTS: Leslie?

4 MEMBER LESLIE: Yes.

5 SECRETARY POTTS: McMurray?

6 MEMBER McMURRAY: Yes.

7 SECRETARY POTTS: Russo?

8 MEMBER RUSSO: Yes.

9 SECRETARY POTTS: And Barringer?

10 VICE-CHAIR BARRINGER: Yes.

11 (Public hearing and relevant agenda  
12 items concluded at or about the hour of 9:14 a.m.)

13

14

15

16

17

18

19

20

21

22

23

24

25



# Tawas Utilities Authority

810 West Franklin Street • East Tawas, Michigan 48730

## BOARD MEMBERS

### CITY OF EAST TAWAS

Brent Barringer  
TUA Vice Chair  
East Tawas City Manager  
(989) 362-6161  
bbarringer@easttawas.com

David Leslie  
TUA Board Member  
East Tawas Councilman

Bruce Bolen  
TUA Alternate  
East Tawas Mayor

### CITY OF TAWAS CITY

Annge Horning  
TUA Chair  
Tawas City Manager  
(989) 362-8688  
ahorning@tawascity.org

Michael Russo  
TUA Board Member  
Tawas City Councilman

Brian McMurray  
TUA Alternate  
Tawas City Councilman

## PLANT OPERATOR

John Bannen  
Operations Support Manager  
Inframark Water  
Infrastructure Operations

## A RESOLUTION ADOPTING A FINAL PROJECT PLAN FOR WASTEWATER SYSTEM IMPROVEMENTS or NPS POLLUTION CONTROL/STORMWATER IMPROVEMENTS AND DESIGNATING AN AUTHORIZED PROJECT REPRESENTATIVE

**WHEREAS**, the Tawas Utilities Authority recognizes the need to make improvements to its existing wastewater treatment system; and

**WHEREAS**, the Tawas Utilities Authority authorized C2AE Architecture-Engineering to prepare a Project Plan, which recommends the construction of various WWTP improvements, including improvements to the following elements: headworks; sludge processing, pumping, storage and mixing; disinfection system; electrical, controls and structural, safety and other improvements; and

**WHEREAS**, said Project Plan was presented at a Public Hearing held on May 27, 2021 at 9:00 a.m. and all public comments have been considered and addressed;

**NOW THEREFORE BE IT RESOLVED**, that the Tawas Utilities Authority formally adopts said Project Plan and agrees to implement the selected alternative (Alternative No. 2), dependent upon the successful acquisition of adequate funding.

**BE IS FURTHER RESOLVED** that the Chair and/or Vice Chair, positions currently held by Annge Horning and Brent Barringer, are designated as authorized representatives for all activities associated with the project referenced above, including the submittal of said Project Plan as the first step in applying to the State of Michigan for a revolving fund loan to assist in the implementation of the selected alternative.

Yes: Barringer, Leslie, McMurray and Russo

No: None

Abstain: None

Absent: None

I certify that the above Resolution was adopted by the Tawas Utilities Authority on May 27, 2021.

BY: Julie J. Potts  
Julie J. Potts, Secretary/Treasurer

DATE: 5/27/2021

## **APPENDIX F**

### **PROCESS FLOW DIAGRAMS**









## **APPENDIX G**

### **DESIGN DATA AND PROCESS MODELING**



123 W. Main St., Suite 200  
 Gaylord, MI 49735  
 O: 989.732.8131

**Tawas Utilities Authority SRF Project Pla**

**BASIS OF DESIGN FOR WWTP**

	<b>Concentration</b>	<b>Mass Loading</b>
<b>Parameter</b>	<b>mg/l</b>	<b>Lb./day</b>
BOD-5	132.0	2,642.1
COD	158.4	3,170.5
Suspend Solids	140.0	2,802.2
Volitale Suspended Solids	122.0	2,442.0
Phosphorus	3.5	70.1
NH <sub>3</sub> - N	12.7	254.2
pH, Std. Units	7.50	
Flow, MGD	2.40	





123 W. Main St., Suite 200  
Gaylord, MI 49735  
O: 989.732.8131

**Tawas Utilities Authority SRF Project Plan**

**WASTE SOLIDS GENERATION AND STORAGE**

<u>Waste to Thickener</u>	<u>Gallons</u>
Avg Monthly	338,480
Avg Daily	1,268
Max Daily	3,000
Min Daily	410

<u>Land Application Volumes</u>	<u>Gallons</u>
May-18	943,500
Aug-18	391,000
May-19	425,000
Sep-19	525,000
Apr-20	480,250
Spring Ave	452,625
Fall	458,000
Annual	910,625

<u>Storage Volume</u>	<u>Gallons</u>
Existing Tank	510,500
Proposed Tank	510,500
Total Volume	1,021,000

Tawas Utilities Authority SRF Project Plan

**EFFLUENT DATA SUMMARY**

Month/Year	FINAL EFFLUENT QUANTITY														
	Flow	CBOD - 5			Suspended Solids			VSS	Phosphorus		NH <sub>3</sub> - N		DO	F Coli	Cl <sub>2</sub>
	MGD	Mg/L	Lbs	% Rem	Mg/L	Lbs	% Rem	Mg/L	Mg/L	Lbs	Mg/L	Lbs	Mg/L	#/C ml	µg/L
Oct-17	0.680	2.86	16.2	97.7%	1.7	9	98.8%	1.30	0.52	2.94	0.54	3.04	5.9	11	0.014
Nov-17	0.749	2.53	15.9	97.8%	1.8	12	98.6%	1.20	0.39	2.42	0.12	0.74	7.0	9	0.015
Dec-17	0.664	2.57	14.1	97.9%	2.6	13	97.9%	1.70	0.28	1.52	0.15	0.81	7.7	4	0.013
Jan-18	0.723	2.16	12.9	98.2%	2.1	12	98.3%	1.30	0.54	3.19	0.13	0.74	8.3	7	0.010
Feb-18	0.898	2.29	16.7	98.0%	1.7	12	98.7%	0.70	0.39	2.73	0.15	1.20	9.3	5	0.014
Mar-18	0.865	2.29	15.9	97.8%	1.4	10	98.8%	0.70	0.38	2.57	0.16	1.14	9.1	9	0.010
Apr-18	1.359	2.68	31.6	96.1%	3.4	44	95.6%	2.80	0.48	5.27	0.75	10.26	8.7	38	0.016
May-18	1.032	2.29	19.8	97.5%	2.7	23	97.6%	2.00	0.42	3.56	0.34	2.89	7.1	35	0.011
Jun-18	0.808	2.08	13.9	98.4%	4.4	29	97.1%	3.30	0.37	2.52	0.21	1.40	6.7	50	0.010
Jul-18	0.812	3.41	23	97.8%	3.1	21	98.2%	2.50	0.74	5.08	7.27	48.43	5.4	12	0.011
Aug-18	0.770	3.88	24.4	97.5%	2.4	15	98.6%	1.70	0.74	4.86	8.69	55.01	6.4	15	0.014
Sep-18	0.733	2.96	19.2	97.8%	4.8	31	97.8%	3.50	0.78	4.65	2.25	16.95	6.4	46	0.011
Oct-18	0.885	2.23	15.9	98.0%	3.4	24	97.3%	2.20	0.63	4.51	0.14	1.01	6.8	42	0.013
Nov-18	0.988	2.14	17.9	97.7%	1.5	13	98.6%	0.90	0.31	2.57	0.13	1.16	7.3	16	0.018
Dec-18	0.950	2.22	17.8	97.6%	1.9	16	98.3%	1.30	0.37	2.94	0.10	0.83	8.2	16	0.014
Jan-19	0.817	2.07	13.9	98.0%	3.1	19	97.7%	2.10	0.34	2.25	0.10	0.68	8.9	28	0.012
Feb-19	0.848	2.62	18.9	97.3%	3.0	22	97.3%	1.90	0.36	2.66	0.19	1.64	8.6	54	0.013
Mar-19	1.115	4.11	40.4	95.3%	5.7	58	94.1%	3.80	0.52	5.07	1.94	21.17	7.7	46	0.013
Apr-19	1.280	2.46	24.8	96.3%	1.9	20	97.4%	1.10	0.25	2.80	0.46	6.26	8.0	23	0.014
May-19	1.229	3.23	32.9	95.9%	3.4	36	96.3%	2.80	0.46	4.97	0.95	10.73	7.3	60	0.012
Jun-19	1.254	6.58	77.3	93.6%	9.0	109	91.7%	6.10	0.46	5.51	1.80	24.45	6.3	107	0.011
Jul-19	0.938	4.01	30.8	97.1%	4.8	35	97.1%	3.60	0.46	3.55	3.87	29.82	6.5	25	0.010
Aug-19	0.796	4.32	28.1	97.4%	3.1	20	97.7%	2.30	0.50	3.35	6.26	40.23	5.9	21	0.012
Sep-19	0.784	2.56	15.9	98.0%	2.4	14	97.9%	1.70	0.38	2.34	3.20	18.08	6.4	47	0.012
Oct-19	0.901	2.23	16.4	97.6%	2.5	18	97.2%	1.40	0.46	3.32	0.11	0.83	7.2	53	0.011
Nov-19	1.169	4.52	40.4	94.5%	2.3	22	97.3%	1.80	0.48	4.36	0.11	0.97	8.3	30	0.014
Dec-19	1.308	2.46	25.7	96.5%	2.2	23	96.7%	1.50	0.49	5.07	0.16	1.69	8.2	112	0.014
Jan-20	1.434	5.81	73.8	90.2%	11.4	151	84.2%	7.10	0.82	10.68	3.78	50.00	7.0	101	0.016
Feb-20	1.077	3.31	29.7	95.4%	5.0	44	92.6%	2.30	0.65	6.17	1.54	13.72	10.9	10	0.015
Mar-20	1.196	9.99	102.1	81.5%	38.6	392	34.6%	27.80	0.72	7.32	3.27	32.15	8.8	261	0.013
Apr-20	0.901	2.33	16	97.1%	4.3	29	95.8%	2.90	0.20	1.41	0.11	6.49	9.3	19	0.010
May-20	1.855	3.88	70.4	93.2%	8.2	156	87.6%	5.90	0.30	4.96	1.28	21.51	7.9	139	12.500
Jun-20	1.222	3.2	30.5	96.3%	5.6	50	94.7%	4.00	0.27	2.48	5.47	48.31	7.0	31	0.015
Jul-20	0.841	2.27	15.9	98.1%	4.8	33	95.6%	3.10	0.26	1.84	1.86	13.36	6.5	31	10.000
Aug-20	0.876	2.29	16.5	97.7%	12.5	96	88.5%	9.30	0.62	4.63	0.47	3.40	6.5	61	10.000
Sep-20	0.766	5.23	36.5	96.0%	24.3	186	83.0%	18.10	0.98	6.87	3.85	25.12	6.8	27	10.000
	FINAL EFFLUENT QUANTITY														
	Flow	CBOD - 5			Suspended Solids			VSS	Phosphorus		NH <sub>3</sub> - N		DO	F Coli	Cl <sub>2</sub>
	MGD	Mg/L	Lbs	% Rem	Mg/L	Lbs	% Rem	Mg/L	Mg/L	Lbs	Mg/L	Lbs	Mg/L	#/C ml	µg/L
Minimum	0.664	2.07	12.9	81.5%	1.4	9	34.6%	0.70	0.20	1.41	0.10	0.68	5.4	4	0.01
Average	0.987	3.28	28.7	96.4%	5.5	50	94.0%	3.83	0.48	3.97	1.72	14.34	7.5	44	1.19
Maximum	1.855	9.99	102.1	98.4%	38.6	392	98.8%	27.80	0.98	10.68	8.69	55.01	10.9	261	12.50



Existing TUA WWTP Biological Process Model

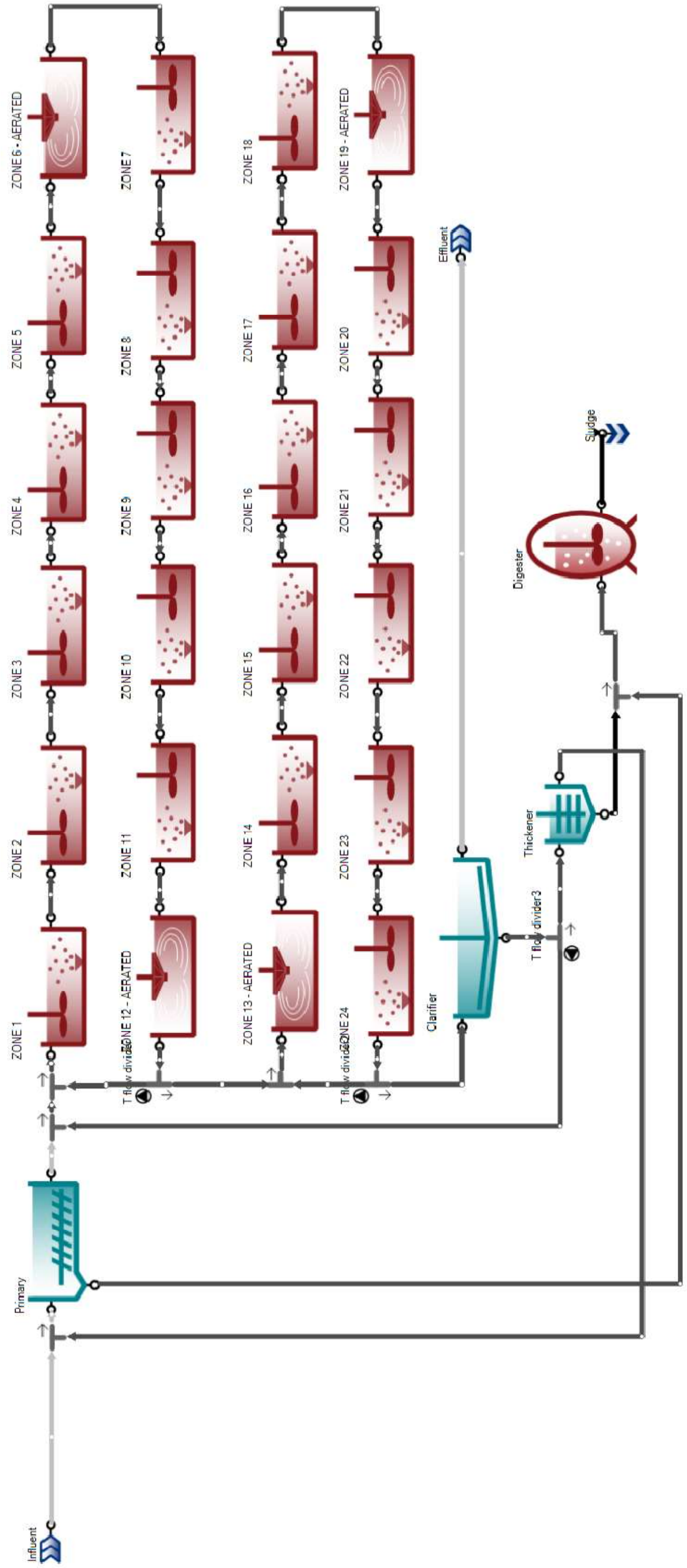



123 W. Main St., Suite 200  
 Gaylord, MI 49735  
 O: 989.732.8131

**Tawas Utilities Authority SRF Project Plan**

**EXISTING FACILITY FLOW MODEL EFFLUENT RESULTS**

	<b>Concentration</b>	<b>Mass Loading</b>
<b>Parameter</b>	<b>mg/l</b>	<b>Lb/day</b>
Total chemical oxygen demand mass flow	36.61	305.32
Total suspended solids (TSS) mass flow	18.01	150.22
Volatile suspended solids (VSS) mass flow	13.74	114.57
Total biochemical oxygen demand (5 days) mass flow	2.52	21.01
Total nitrogen mass flow	4.53	37.77
Nitrate and nitrite (NOx) mass flow	1.87	15.64
Total ammonia (NHx) mass flow	0.31	2.58
Total phosphorus mass flow	7.19	60.00
Orthophosphate (PO4) mass flow	6.77	56.48

### Option One TUA WWTP Plant Model

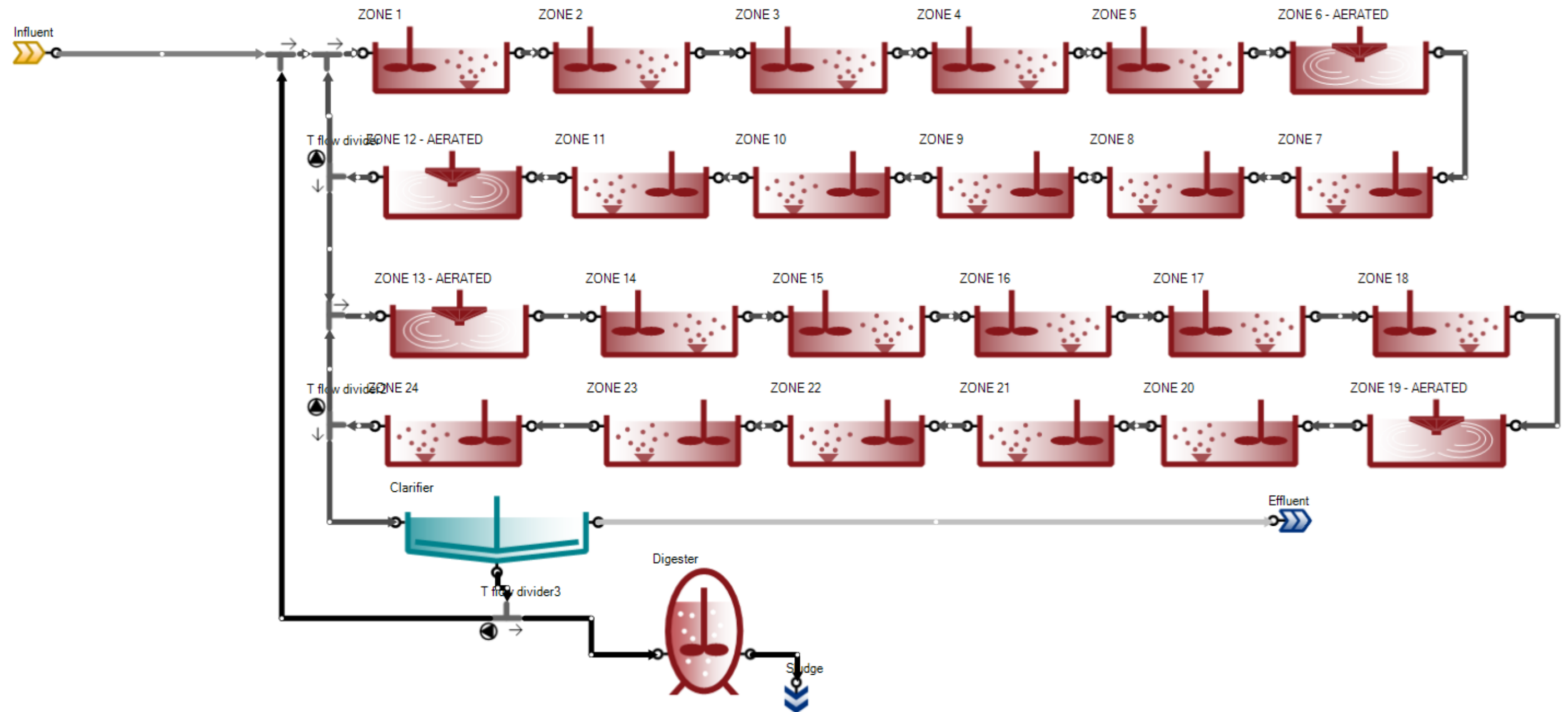



123 W. Main St., Suite 200  
 Gaylord, MI 49735  
 O: 989.732.8131

**Tawas Utilities Authority SRF Project Plan**

**OPTION ONE MODEL EFFLUENT RESULTS**

	<b>Concentration</b>	<b>Mass Loading</b>
<b>Parameter</b>	<b>mg/l</b>	<b>Lb/day</b>
Total chemical oxygen demand mass flow	21.40	178.48
Total suspended solids (TSS) mass flow	14.91	124.32
Volatile suspended solids (VSS) mass flow	9.76	81.38
Total biochemical oxygen demand (5 days) mass flow	2.29	19.12
Total nitrogen mass flow	8.16	68.03
Nitrate and nitrite (NOx) mass flow	6.78	56.53
Total ammonia (NHx) mass flow	0.10	0.87
Total phosphorus mass flow	12.88	107.44
Orthophosphate (PO4) mass flow	12.01	100.18

## **APPENDIX H**

### **DISADVANTAGED COMMUNITY STATUS**

## Disadvantaged Community Status Determination Worksheet

The following data is required from each municipality in order to assess the disadvantaged community status. Please provide the necessary information and return to:

Robert Schneider  
Water Infrastructure Financing Section  
Finance Division  
P.O. Box 30457  
Lansing, MI 48909-7957  
[Schneiderr@michigan.gov](mailto:Schneiderr@michigan.gov)

If you have any questions, please contact Robert Schneider at 517-388-6466

Please check the box this determination is for:

DWRF     SRF

1. Total amount of anticipated debt for the proposed project, if applicable.

\$10,997,000

2. Annual payments on the existing debt for the system.

\$0 \_\_\_\_\_

3. Total operation, maintenance and replacement expenses for the system on an annual basis.

\$1,305,980    See attached expense calculation worksheet

4. Number of "residential equivalent users" in the system.

2,500    See attached REU calculation worksheet

**For determinations made using anticipated debt, a final determination will be made based upon the awarded loan amount.**

(EQP 3530 REV 7/11/19)

### TUA Sewer Expense Calculation for Disadvantaged Community Determination

TUA Member Communities Sewer Expenses	Sewer Expenses		
	Total Sewer Expenses incl. Depreciation	Depreciation Expense	Total Sewer Expenses w/o Depreciation
Sewer System Expenses - Includes TUA Charges			
East Tawas Audit	\$ 607,816	\$ 92,855	\$ 514,961
Tawas City Audit	\$ 697,860	\$ 43,116	\$ 654,744
*Baldwin Twp Audit	\$ 201,523	\$ 65,248	\$ 136,275
<b>Total Sewer Expenses TUA Customers</b>	<b>\$ 1,507,199</b>		<b>\$ 1,305,980</b>

\* Baldwin Twp does not separate water and sewer accounts. Assumed 50% of total

Note: For calculating total sewer costs per customers for Disadvantaged Community determination, the total sewer expenses for all member communities needs to be included. Expenses above include the expenses passed down from the TUA.

**TUA REU Calculations for Disadvantaged Community Determination  
TUA Billed Sewer Flow Information**

**City of East Tawas**

Year	Metered and Estimated - All Customers (gallons)	Total Number of Sewer Customers	Total Metered Usage - Residential Customers Only (gallons)	Total Number of Metered Residential Customers	Total Billed Usage - Residential Non-Metered Customers Only (gallons)	Total Number of Non-metered Residential Customers	Total Avg Billed Usage/Mo	Avg. Residential Usage/Mo	*Adjusted Avg. Res. Usage/Mo (gallons)	Usage - Residential Only July 2020 (gallons)	Total Metered Residential Customers	Avg. Residential Usage/July 2020 (gallons)
2019-2020	56,169,000	1550	37,265,500	1207	10,488,000	190	3020	2,573	4129	4,983,400	1207	4129
2018-2019	55,246,500	1551	35,189,300	1207	10,543,200	191	2968	2,430				
2017-2018	58,127,300	1553	36,378,100	1207	10,653,600	193	3119	2,512				

\* East Tawas residential billings fluctuate due to seasonal customers/usage. Use month of July to establish REU's

**City of Tawas City**

Year	Total Billed Usage - Metered and Estimated - All Customers (gallons)	Total Number of Sewer Customers	Total Metered Usage - Residential Customers Only (gallons)	Total Number of Metered Residential Customers	Total Billed Usage - Residential Non-Metered Customers Only (gallons)	Total Number of Non-metered Residential Customers	Total Avg Billed Usage/Mo	Avg. Residential Usage/Mo	*Adjusted Avg. Res. Usage/Mo (gallons)
2020			46,851,176	791	342,700	17		4,936	4,936
2019	65,531,068	1304	45,861,200	789	272,100	17	4188	4,844	
2018	65,692,752	1304	45,883,300	789	334,600	17	4198	4,846	

**Baldwin Township**

Year	Total Billed Usage - Metered and Estimated - All Customers (gallons)	Total Number of Sewer Customers	Total Metered Usage - Residential Customers Only (gallons)	Total Number of Metered Residential Customers	Total Billed Usage - Residential Non-Metered Customers Only (gallons)	Total Number of Non-metered Residential Customers	Total Avg Billed Usage/Mo	Avg. Residential Usage/Mo	*Adjusted Avg. Res. Usage/Mo (gallons)
2020	10,841,806	83	526,000	20	36,000	2	10885	2,192	2,192
2019	9,973,605	82	274,200	20	36,000	2			
2018	9,766,833	82	242,000	20	36,000	2			

**Totals      132,541,874.00      2937      Total Adjusted Residential Usage (Gal/Mo/REU)      4,426**

**Total number of REU's = Total Flow/Adjusted Average Residential Usage = 2,496  
Use 2500**



TOWNSHIP OF BALDWIN  
Losco County, Michigan

STATEMENT OF REVENUE, EXPENSES AND CHANGES IN NET POSITION  
 PROPRIETARY FUND  
For the Year Ended March 31, 2020

	<u>Enterprise Fund</u>
	Water and Sewer Fund
<u>Operating Revenue</u>	
Charges For Services	\$ <u>341,824</u>
<u>Operating Expenses</u>	
Salaries and Wages	89,443
Payroll Taxes and Employee Benefits	10,429
Administrative Costs	24,000
Depreciation	130,945
Dues and Subscriptions	2,227
Insurance and Bonds	3,223
Operating Supplies	3,305
Professional Fees and Services	38,194
Repair and Maintenance	7,045
Telephone	11,080
Travel and Training	3,643
Utilities	4,166
Water and Sewer	75,212
Other	133
Total Operating Expenses	<u>403,045</u>
Operating Income (Loss)	<u>(61,221)</u>
<u>Nonoperating Revenue (Expenses)</u>	
Interest on Special Assessments	1,580
Interest and Investment Earnings	7,891
Interest and Fees Expense	(5,245)
Gain (Loss) on Disposal of Capital Assets	1,000
Total Nonoperating Revenue (Expenses)	<u>5,226</u>
Change in Net Position	(55,995)
Net Position - Beginning of Year (Restated)	<u>5,145,146</u>
Net Position - End of Year	<u>\$ <u>5,089,151</u></u>

The accompanying notes to financial statements are an integral part of this statement.

CITY OF TAWAS CITY  
Losco County, Michigan

STATEMENT OF REVENUE, EXPENSES AND CHANGES IN NET POSITION  
 PROPRIETARY FUNDS  
For the Year Ended June 30, 2020

	Enterprise Funds		
	Major Funds		Total
	Sewer	Water	
<u>Operating Revenue</u>			
Charges For Services	\$ 679,792	\$ 548,799	\$ 1,228,591
Penalties	5,889	4,316	10,205
Other Revenue	1,217	2,610	3,827
Total Operating Revenue	<u>686,898</u>	<u>555,725</u>	<u>1,242,623</u>
<u>Operating Expenses</u>			
Salaries and Wages	86,813	71,139	157,952
Payroll Taxes and Employee Benefits	14,978	12,502	27,480
Administrative Costs	3,633	3,515	7,148
Contractual Services	473,199	180,308	653,507
Depreciation	43,116	105,362	148,478
Equipment Rental	17,004	12,435	29,439
Insurance and Bonds	4,501	4,501	9,002
Operating Supplies	9,310	16,512	25,822
Repair and Maintenance	22,548	12,719	35,267
Travel and Training	0	1,286	1,286
Utilities	22,300	0	22,300
Other	458	4,550	5,008
Total Operating Expenses	<u>697,860</u>	<u>424,829</u>	<u>1,122,689</u>
Operating Income (Loss)	(10,962)	130,896	119,934
<u>Nonoperating Revenue (Expenses)</u>			
Interest and Investment Earnings	<u>12,359</u>	<u>22,935</u>	<u>35,294</u>
Change in Net Position	1,397	153,831	155,228
Net Position - Beginning of Year	<u>2,535,094</u>	<u>7,368,782</u>	<u>9,903,876</u>
Net Position - End of Year	<u>\$ 2,536,491</u>	<u>\$ 7,522,613</u>	<u>\$ 10,059,104</u>

The accompanying notes to financial statements are an integral part of this statement.

CITY OF EAST TAWAS  
Losco County, Michigan

STATEMENT OF REVENUE, EXPENSES AND CHANGES IN NET POSITION  
 PROPRIETARY FUNDS  
For the Year Ended September 30, 2020

	Enterprise Funds			
	Major Funds			Total
	Sewer Fund	Water Fund	City Park Fund	
<u>Operating Revenue</u>				
Charges For Services	\$ 524,121	\$ 495,466	\$ 893,465	\$ 1,913,052
Service Connection Charges	4,000	0	0	4,000
Penalties	6,965	5,721	0	12,686
Other Revenue	0	1,747	1,658	3,405
Total Operating Revenue	<u>535,086</u>	<u>502,934</u>	<u>895,123</u>	<u>1,933,143</u>
<u>Operating Expenses</u>				
Salaries and Wages	50,520	55,116	267,517	373,153
Payroll Taxes and Employee Benefits	20,978	23,566	77,216	121,760
Advertising	0	0	1,009	1,009
Contractual Services	407,623	169,096	2,420	579,139
Depreciation and Amortization	92,855	100,990	128,348	322,193
Equipment	0	0	26,518	26,518
Equipment Rental	4,732	5,578	0	10,310
Insurance and Bonds	5,328	1,377	21,102	27,807
Office Supplies	3,808	3,815	666	8,289
Operating Supplies	1,545	6,029	16,115	23,689
Professional Fees and Services	0	0	6,670	6,670
Repair and Maintenance	7,121	3,451	48,362	58,934
Travel and Training	340	1,060	0	1,400
Utilities	12,966	0	137,530	150,496
Other	0	0	15,714	15,714
Total Operating Expenses	<u>607,816</u>	<u>370,078</u>	<u>749,187</u>	<u>1,727,081</u>
Operating Income (Loss)	<u>(72,730)</u>	<u>132,856</u>	<u>145,936</u>	<u>206,062</u>
<u>Nonoperating Revenue (Expenses)</u>				
Interest and Investment Earnings	9,643	13,686	6,046	29,375
Interest and Fees Expense	0	(30,623)	0	(30,623)
Total Nonoperating Revenue (Expenses)	<u>9,643</u>	<u>(16,937)</u>	<u>6,046</u>	<u>(1,248)</u>
Income (Loss) Before Capital Contributions and Operating Transfers	(63,087)	115,919	151,982	204,814
Capital Contributions	0	0	157,622	157,622
Operating Transfers Out	0	0	(169,656)	(169,656)
Change in Net Position	(63,087)	115,919	139,948	192,780
Net Position - Beginning of Year	<u>2,900,215</u>	<u>3,592,942</u>	<u>3,074,927</u>	<u>9,568,084</u>
Net Position - End of Year	<u>\$ 2,837,128</u>	<u>\$ 3,708,861</u>	<u>\$ 3,214,875</u>	<u>\$ 9,760,864</u>

The accompanying notes to financial statements are an integral part of this statement.

## **APPENDIX I**

### **GREEN PROJECT RESERVE INFORMATION**

**Tawas Utilities Authority SRF Project Plan**

**GREEN PROJECT RESERVE**

**Premium Efficiency Motors**

General – The four Oxidation Ditch Rotors are each driven by 25hp electric motors and the two Return Activated Sludge (RAS) Pumps are each driven by 10hp electric motors. Replacing these six motors with premium efficiency motors will result in energy savings due to the higher efficiency of the premium efficiency motors in comparison with the existing motors.

Cost – The estimated project cost for these motor replacements is as follows:

Construction.....	\$ 7,800
General Conditions....	\$ 2,300
Engineering.....	\$ 1,200
TOTAL.....	\$ 11,300

Energy Savings – The energy savings will be the result of utilizing higher efficiency motors.

Existing Oxidation Ditch Rotor and RAS Pump Energy Use – 450,702 kWh/year (~\$42,817/year)

Proposed Oxidation Ditch Rotor and RAS Pump Energy Use – 417,151 kWh/year (~\$39,630/year)

Energy Savings: (450,702 – 417,151) kWh = 33,551 kWh (~\$3,187/year)

**This is not GPR eligible since it does not reduce energy consumption by 20% or more.**

**Interior and Exterior Lighting**

General – Throughout the facility the existing high intensity discharge and fluorescent interior and exterior lighting will be replaced with LED energy efficient lighting fixtures. Lighting controls will also be upgraded to utilize vacancy/occupancy sensors, timers and dimming where required by the Michigan Energy Code. These upgrades will result in an increase in energy efficiency of the lighting system and decrease the overall lighting energy consumption and maintenance requirements.

Cost – The estimated project cost for these improvements is as follows:

Construction.....	\$ 40,000
General Conditions....	\$ 1,200
Engineering.....	\$ 1,500
TOTAL.....	\$ 42,700

Energy Savings – The energy savings will be the result of utilizing more energy efficient lighting fixtures and providing them with controls to minimize wasted energy usage.

Existing Lighting Energy Use – 53,040 kWh/year (~\$5,038/year)  
Proposed Lighting Energy Use - 29,950 kWh/year (~\$2,845/year)  
Energy Savings: (53,040 – 29,950) kWh = 23,090 kWh (~\$2,193/year)  
20% Energy Reduction – 53,040kWh/year \* 20% = 10,608 kWh/year

Eligibility – This improvement is categorically eligible because it achieves a 20% reduction in energy consumption.

### **Variable Frequency Drives**

General – The three-20hp influent pumps were provided with variable frequency drives (VFDs) as part of the 1990 facility upgrade project. Currently available VFDs are more efficient and replacement of the existing will result in electrical energy savings

Cost – The estimated project cost for these VFD replacements is as follows:

Construction.....	\$ 6,000
General Conditions....	\$ 1,800
Engineering.....	\$ 400
TOTAL.....	\$ 8,200

Energy Savings – The energy savings will be the result of utilizing higher efficiency motors.

Existing Influent Pump Energy Use – 72,620 kWh/year (~\$6,899/year)  
Proposed Influent Pump Energy Use – 67,364 kWh/year (~\$6,480/year)  
Energy Savings: (76,620 - 67364) kWh = 5,256 kWh (~\$499/year)

**This is not GPR eligible since it does not reduce energy consumption by 20% or more.**

### **Geothermal Heating for Control Building**

General – The Operations building is heated using hydronic system with heat provided by the boiler integrated with the anaerobic digesters. The original intent of the system was to use methane gas produced in the anaerobic digester to maintain the required temperatures in the digesters and heat the control building. The current digesters do not produce sufficient gas to maintain the required heat levels in the winter, requiring make-up natural gas. Energy use for the building will need to be estimated as due to the single boiler being used for digester and building heat.

The control building is a single story brick structure built in 1966 and expanded in 1986. The total first plan area is 5,000 SFT on the main level, and 350-sft below grade in the pump room.

The proposed system is a geothermal type system that will use the treated effluent as a heat source. The average temperature of the water is typically 40 to 50 degrees in winter making this a viable option.

Estimated Heating Load – Current Gas system

Annual Heating Load: 321,000,000 BTU/yr assuming 60% eff boiler system

Annual Energy Consumption: 5,350 SF at 100,000 BTU per SF = 535,000,000 BTU/yr

Estimated Heating Load – Proposed Geothermal system

Annual Heating Load: 3,210,000 BTU/yr

Annual Energy Consumption: 377,600,000 BTU/yr assuming 85% eff heat pump system

Cost – The estimated project cost for the HVAC system Upgrade is: motor replacements is as follows:

Construction.....	\$ 86,000
General Conditions....	\$ 6,880
Engineering.....	<u>\$ 13,900</u>
TOTAL.....	\$ 106,812

Energy Savings – The energy savings will be the result of utilizing higher efficiency heat pump system (using equivalent energy units).

Existing gas fired boiler: energy use per year: 5,350 MBTU

Proposed geothermal heat system: Energy use per year: 3,776 MBTU

Energy Savings: 1,574 MBTU

Percent reduction: 29%